

Simple Circuit Detects Loss of 4-20 mA Signal

National Semiconductor
 Application Note 300
 Robert A. Pease
 May 1982



Simple Circuit Detects Loss of 4-20 mA Signal

Four-to-twenty milliampere current loops are commonly used in the process control industry. They take advantage of the fact that a remote amplifier can be powered by the same 4-20 mA current that it controls as its output signal, thus using a single pair of wires for signal and power. Circuits for making 4-20 mA transmitters are found in the LM10, LM163, and LH0045 data sheets.

In general, an expensive isolation amplifier would be required to detect the case of a 4 mA signal falling out of spec (e.g., 3.7 mA) without degrading the isolation of the 4-20 mA current loop.

But this new circuit (Figure 1) can detect a loss or degradation of signal below 4 mA, with simplicity and low cost. The LM10 contains a stable reference at pins 1 and 8, 200 mV positive referred to pin 4. As long as the loop current is larger than 4 mA, the $I \times R$ drop across the 47.6Ω resistor, R4, is sufficient to pull the LM10's amplifier input (pin 2) below pin 3 and keep its output (pin 6) turned OFF.

The 4-20 mA current will flow through the LED in the optoisolator and provide a LOW output at pin 5 of the optoisolator.

When the current loop falls below 3.7 mA, the LM10's input at pin 2 will rise and cause the pin 6 output to fall and steal all the current away from the LED in the optoisolator. Pin 5 of the 4N28 will rise to signify a *fault* condition. This *fault* flag will fly for any loop current between 3.7 mA and 0.0 mA (and also in case of reversal or open-circuit). R1 is used to trim the threshold point to the desired value. CR2 is added in series with the LED to make sure it will turn OFF when the LM10's output goes LOW. (While the LM10 is guaranteed to saturate to 1.2V, the forward drop of the LED in the 4N28 may be as low as 1.0V, so a diode is added in series with the LED, to insure that it can be shut off.) Note that most operational amplifiers will not respond in a reasonable way if the output pin (6) is connected to the positive supply pin (7), but the LM10 was specifically designed and is specified to perform accurately in this "shunt" mode. (Refer to AN-211 application note, TP-14 technical paper, and the LM10 data sheet.)

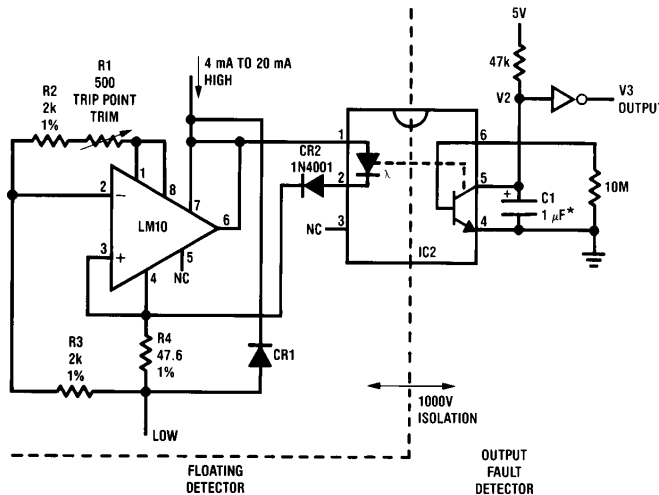

- CR1 = 1N4001, optional, in case of signal reversal
- LM10 = NSC LM10CLN or LM10CLH amp/reference
- IC2 = 4N28 or similar, optoisolator
- V2 = Normally low; high signifies fault ($I < 3.7$ mA)
- V3 = Normally high; low signifies fault ($I < 3.7$ mA) (buffered output)
- *C1 = 1 μF optional, to avoid false output when large AC current is superimposed on 4.0 mA. Disconnect this capacitor when using with circuit of Figure 2.
- ◻ = 1/6 MM74C04 or similar, CMOS inverter

FIGURE 1. Current Loop Fault Detector

TL/H/5640-1

AN-300

While you could manually adjust R1 while observing the status of V3 output, this would be a coarse and awkward trim procedure. Figure 2 shows an improved test circuit which serves the current through the detector circuit, forcing it to be at the threshold value. Then that current can be monitored continuously, and the circuit can be trimmed easily. If the current through R107 starts out too small, the output of the 4N28 will be HIGH too much of the time, and the op amp output will integrate upwards until the current is at the actual threshold of the detector. The integrator's output will stop at the value where the duty cycle of the 4N28 out-

put is exactly 50%. This occurs when the current through R107 is straddling the threshold value.

The positive feedback via R108 assures that the loop oscillates at approximately 50 cycles per second, with a small, well-controlled sawtooth wave at its output. This mode of operation was chosen to insure that the loop does not oscillate at some high, uncontrolled frequency, as it would be difficult in that case to be sure the duty cycle was exactly 50%. This test circuit is advantageous, because you can measure the trip point directly.

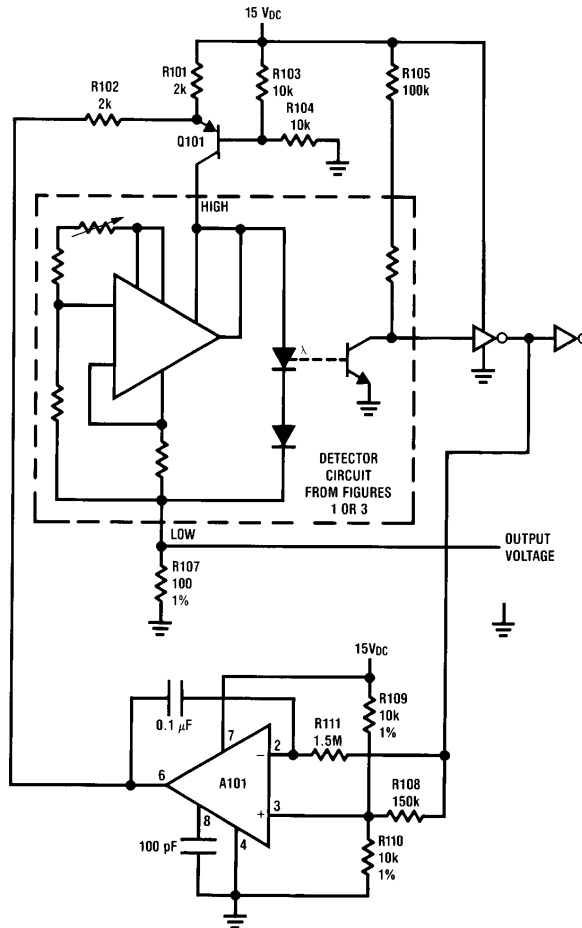

A101 = LM308 or similar
 ◁▷ = 1/6 MM74C04 or similar, CMOS inverter
 Q101 = 2N2907 or similar, PNP

FIGURE 2. Test Circuit for Threshold Detector

TL/H/5640-2

The test circuit of *Figure 2* is necessary for trimming the detector in *Figure 3*. This circuit does not have a trim pot, and thus avoids the problem of someone mis-adjusting the circuit after it is once trimmed correctly. It also avoids the compromises between good but expensive trim pots and cheap but unreliable, drifty trim pots. By opening one or more of the links, L1–L4, according to the following procedure, it is easy to trim the threshold level to be within 1% of 3.70 mA (or as desired).

- Observe the DC current through R107 in *Figure 2*
- If $I_{THRESHOLD}$ is larger than 3.950 mA, open link L1; —if not, don't
- If $I_{THRESHOLD}$ is larger than 3.830 mA, open link L2; —if not, don't

- If $I_{THRESHOLD}$ is larger than 3.760 mA, open link L3; —if not, don't
- Then, if $I_{THRESHOLD}$ is larger than 3.720 mA, open link L4; —if not, don't

This procedure provides a circuit trimmed to much better than 1% of 3.70 mA, without using any trim pots. Of course, this circuit can be used to detect drop-out of regulation of other floating signals, while maintaining high isolation from ground, good accuracy, low power dissipation (2 mA × 2.5V typical) and low cost.

Other standard values of current loop are 1 mA–5 mA and 10 mA–50 mA. The version shown in *Figure 4* uses higher resistance values to trip at 0.85 mA. The circuit in *Figure 5* has an additional transistor, to accommodate currents as large as 50 mA without damage or loss of accuracy, and provide an 8.5 mA threshold.

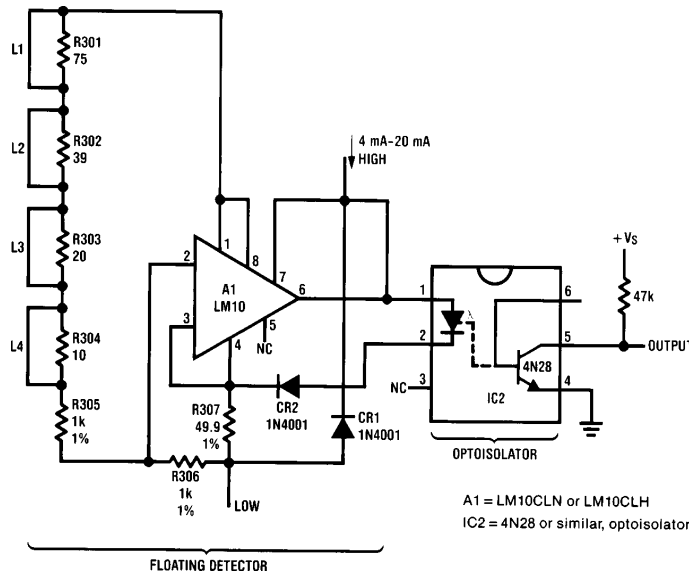

FIGURE 3. Fault Detector with Low-Cost Trim Scheme
(To be trimmed in the circuit of *Figure 2*)

TL/H/5640-3

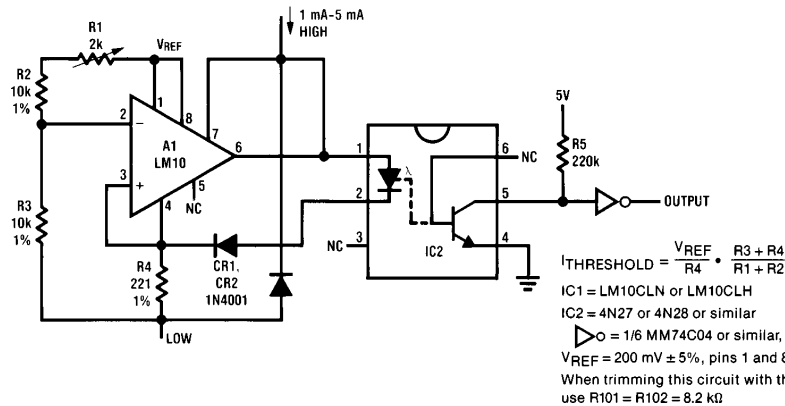
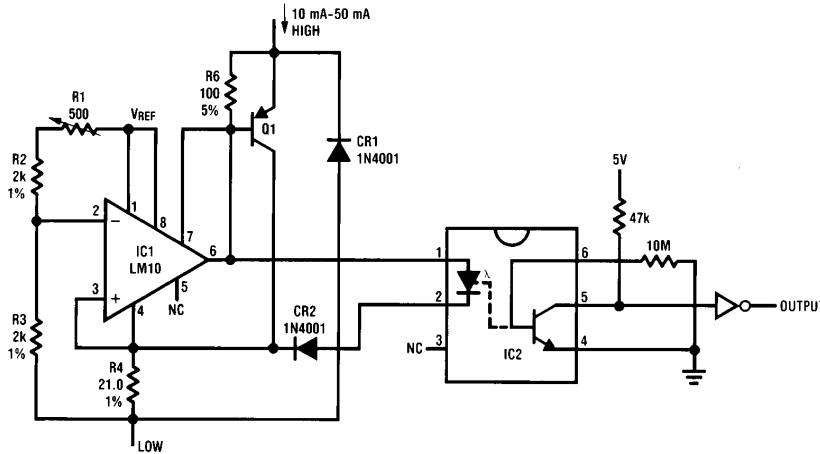

FIGURE 4. Current Loop Fault Detector
($I_{THRESHOLD} = 0.85 \text{ mA}$ for 1 mA–5 mA Current Loops)

TL/H/5640-4



$$-I_{\text{THRESHOLD}} = \frac{V_{\text{REF}}}{R_4} \cdot \frac{R_3 + R_4}{R_1 + R_2}$$

IC1 = LM10CLH or LM10CLN op amp and reference

$V_{\text{REF}} = 200 \text{ mV} \pm 5\%$, pins 1 and 8 referred to pin 4

IC2 = 4N28 or similar, optoisolator

 = 1/6 MM74C04 or similar, CMOS inverter

Q1 = 2N2904 or 2N2907, any silicon PNP

When trimming this circuit with the circuit of Figure 2, use $R_{101} = R_{102} = 820\Omega$

TL/H/5640-5

FIGURE 5. Current Loop Fault Detector
($I_{\text{THRESHOLD}} = 8.5 \text{ mA}$, for 10 mA-50 mA Current Loops)

LIFE SUPPORT POLICY

NATIONAL'S PRODUCTS ARE NOT AUTHORIZED FOR USE AS CRITICAL COMPONENTS IN LIFE SUPPORT DEVICES OR SYSTEMS WITHOUT THE EXPRESS WRITTEN APPROVAL OF THE PRESIDENT OF NATIONAL SEMICONDUCTOR CORPORATION. As used herein:

1. Life support devices or systems are devices or systems which, (a) are intended for surgical implant into the body, or (b) support or sustain life, and whose failure to perform, when properly used in accordance with instructions for use provided in the labeling, can be reasonably expected to result in a significant injury to the user.
2. A critical component is any component of a life support device or system whose failure to perform can be reasonably expected to cause the failure of the life support device or system, or to affect its safety or effectiveness.



National Semiconductor Corporation
1111 West Bardin Road
Arlington, TX 76017
Tel: 1(800) 272-9959
Fax: 1(800) 737-7018

National Semiconductor Europe
Fax: (+49) 0-180-530 85 86
Email: cnjwge@tevm2.nsc.com
Deutsch Tel: (+49) 0-180-530 85 85
English Tel: (+49) 0-180-532 78 32
Français Tel: (+49) 0-180-532 93 58
Italiano Tel: (+49) 0-180-534 16 80

National Semiconductor Hong Kong Ltd.
19th Floor, Straight Block,
Ocean Centre, 5 Canton Rd.
Tsimshatsui, Kowloon
Hong Kong
Tel: (852) 2737-1600
Fax: (852) 2736-9960

National Semiconductor Japan Ltd.
Tel: 81-043-299-2309
Fax: 81-043-299-2408