

DATA SHEET

SAA7388

Error correction and host interface
IC for CD-ROM (ELM)

Preliminary specification
File under Integrated Circuits, IC01

1996 Apr 26

**Error correction and host interface IC for
CD-ROM (ELM)**

SAA7388**CONTENTS**

1	FEATURES
2	GENERAL DESCRIPTION
3	QUICK REFERENCE DATA
4	ORDERING INFORMATION
5	BLOCK DIAGRAM
6	PINNING
7	FUNCTIONAL DESCRIPTION
7.1	CD-DSP interface and data input
7.2	Error correction and EDC check
7.3	Host interface
7.4	Subcode channel Q-to-W buffering
7.5	External buffer memory
7.6	Sub-CPU registers
7.7	Register Descriptions
7.8	Sub-CPU interface
7.9	Host registers
.10	CD-DSP Timings
8	LIMITING VALUES
9	THERMAL CHARACTERISTICS
10	CHARACTERISTICS
11	TIMING CHARACTERISTICS
11.1	Q-to-W subcode interface timing
11.2	External memory SRAM timing
11.3	External memory DRAM timing
11.4	Sub-CPU interface timing
11.5	ATAPI host interface timing
11.6	SANYO compatibility mode host interface timing
11.7	Oak compatibility mode host interface timing
11.8	Crystal oscillator
12	PACKAGE OUTLINE
13	SOLDERING
14	DEFINITIONS
15	LIFE SUPPORT APPLICATIONS

Error correction and host interface IC for CD-ROM (ELM)

SAA7388

1 FEATURES

- CD-ROM (Mode 1) and CD-I (Mode 2 - Form 1 and Form 2) formats supported
- Real-time error detection and correction in hardware
- Suitable for octal speed, $n = 8$.
- Maximum host transfer burst rate of 13.3 Mbyte/s
- Corrects two errors per symbol with erasure correction
- 36 kbit of on-chip error correction buffer RAM
- 12-byte command FIFO and 12-byte status FIFO
- Compatible with the Advanced Technology Attachment (ATA) register set and the Advanced Technology Attachment Program Interface (ATAPI) command set
- Operates with popular memories. (up to 128 kbyte SRAM; 1 to 16 Mbit DRAM, different speed grades, nibble or byte wide)
- Interface to Integrated Drive Electronics (IDE) bus without external bus drivers
- Q-to-W subcode buffering, de-interleaving and correction are supported
- Device can operate with audio RAMs. A RAM test allows bad segments to be identified.

2 GENERAL DESCRIPTION

The SAA7388 decoder is a block decoder buffer manager for high-speed CD-ROM applications that integrates real-time error correction and detection and host interface data transfer functions into a single chip.

The SAA7388 has an on-chip 36-kbit memory. This memory is used as a buffer memory for error and erasure corrections. The chip also has a buffer memory interface thus enabling the connection of SRAM up to 128 kbytes, or DRAM up to 16 Mbits. The on-chip memory is sufficient to buffer 1 sector of data. The external memory can buffer many more, depending on memory size.

The error corrector of the SAA7388 can perform 2-pass error correction in real-time. Buffer memory for this correction is integrated on-chip.

The SAA7388 has a host interface that is compatible with the SANYO LC89510 or OAK OTI-012 and also compatible with the ATA/IDE/ATAPI hard disc interface bus. (All ATAPI registers are present in hardware).

Supply of this Compact Disc IC does not convey an implied license under any patent right to use this IC in any Compact Disc application.

3 QUICK REFERENCE DATA

SYMBOL	PARAMETER	MIN.	TYP.	MAX.	UNIT
V_{DDD1}	digital supply voltage 1	3.0	3.3	3.6	V
V_{DDD2}	digital supply voltage 2	4.5	5	5.5	V
I_{DDD}	supply current	–	60	–	mA
f_{clk}	clock frequency	15.2	48	50.4	MHz
T_{amb}	operating ambient temperature	0	–	+70	°C
T_{stg}	storage temperature	–55	–	+125	°C

4 ORDERING INFORMATION

TYPE NUMBER	PACKAGE		
	NAME	DESCRIPTION	VERSION
SAA7388GP	QFP80	plastic quad flat package; 80 leads; lead length 1.95 mm; body 14 × 20 × 2.8 mm	SOT318-2

Error correction and host interface IC for CD-ROM (ELM)

SAA7388

5 BLOCK DIAGRAM

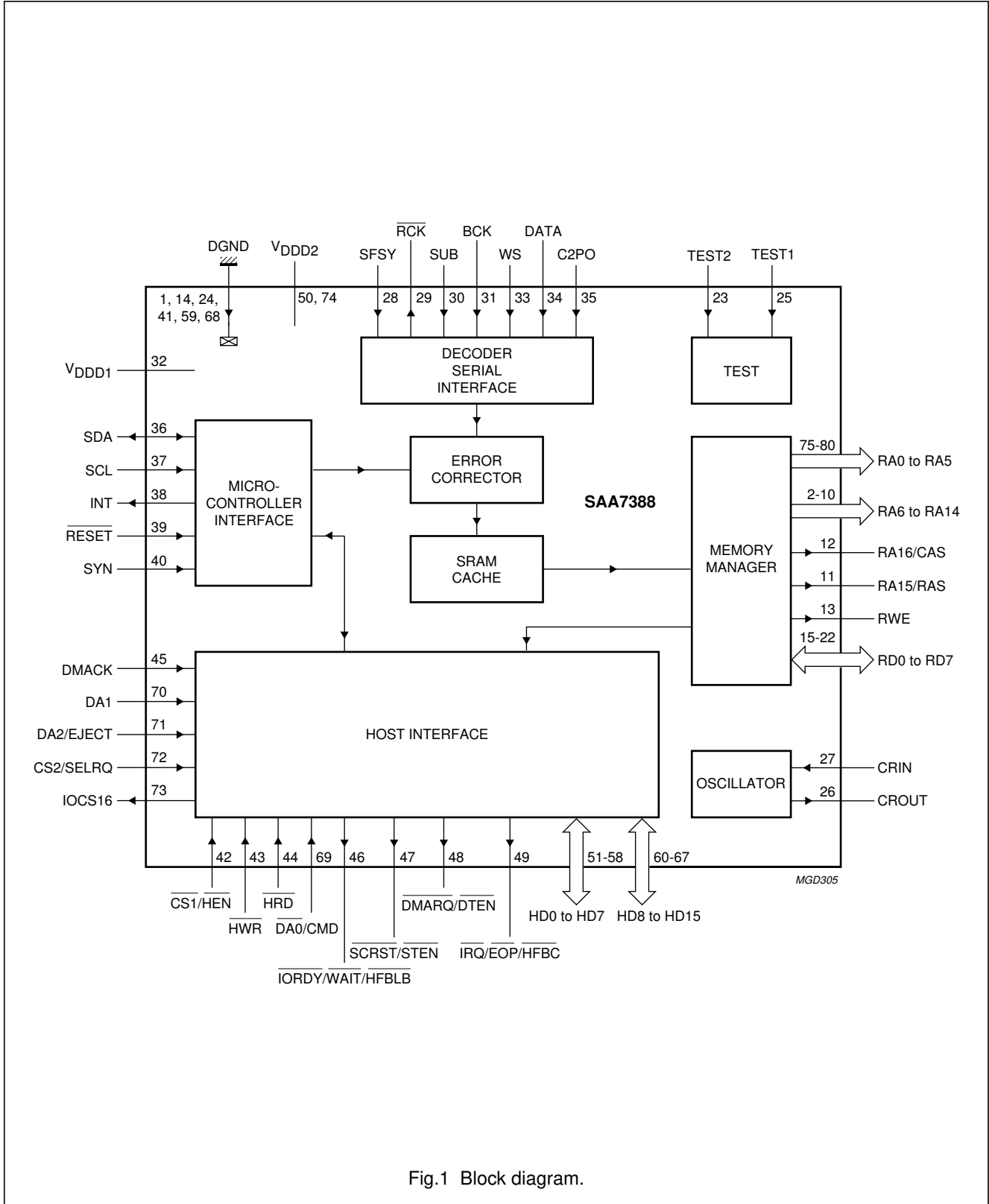

Fig.1 Block diagram.

Error correction and host interface IC for CD-ROM (ELM)

SAA7388

6 PINNING

SYMBOL	PIN	I/O	DESCRIPTION
DGND1	1	–	digital ground 1
RA6	2	O	buffer RAM address bus output line 6
RA7	3	O	buffer RAM address bus output line 7
RA8	4	O	buffer RAM address bus output line 8
RA9	5	O	buffer RAM address bus output line 9
RA10	6	O	buffer RAM address bus output line 10
RA11	7	O	buffer RAM address bus output line 11 (SRAM) only
RA12	8	O	buffer RAM address bus output line 12 (SRAM) only
RA13	9	O	buffer RAM address bus output line 13 (SRAM) only
RA14	10	O	buffer RAM address bus output line 14 (SRAM) only
RA15/RAS	11	O	buffer RAM address bus output line 15 (SRAM) or RAS (DRAM)
RA16/CAS	12	O	buffer RAM address bus output line 16 (SRAM) or CAS (DRAM)
RWE	13	O	buffer RAM write enable output
DGND2	14	–	digital ground 2
RD0	15	I/O	buffer RAM data bus bidirectional line 0
RD1	16	I/O	buffer RAM data bus bidirectional line 1
RD2	17	I/O	buffer RAM data bus bidirectional line 2
RD3	18	I/O	buffer RAM data bus bidirectional line 3
RD4	19	I/O	buffer RAM data bus bidirectional line 4
RD5	20	I/O	buffer RAM data bus bidirectional line 5
RD6	21	I/O	buffer RAM data bus bidirectional line 6
RD7	22	I/O	buffer RAM data bus bidirectional line 7
TEST2	23	I	test input 2
DGND3	24	–	digital ground 3
TEST1	25	I	test input 1
CROUT	26	O	clock oscillator output
CRIN	27	I	clock oscillator input
SFSY	28	I	serial subcode input frame sync input
\overline{RCK}	29	O	serial subcode clock output (active LOW)
SUB	30	I	serial input for Q-to-W subcode input
BCK	31	I	serial interface bit clock input
V _{DD1}	32	–	digital supply voltage 1 (3.3 V)
WS	33	I	serial interface word clock input
DATA	34	I	serial data input
C2PO	35	I	serial interface flag input
SDA	36	I/O	sub-CPU serial data input/output
SCL	37	I	sub-CPU serial clock input
INT	38	O	sub-CPU open-collector interrupt output
\overline{RESET}	39	I	power-on reset input (active LOW)
SYN	40	I	sync signal input from sub-CPU

Error correction and host interface IC for CD-ROM (ELM)

SAA7388

SYMBOL	PIN	I/O	DESCRIPTION
DGND4	41	–	digital ground 4
$\overline{\text{CS1/HEN}}$	42	I	host interface enable input (active LOW)
$\overline{\text{HWR}}$	43	I	host interface write enable input (active LOW)
$\overline{\text{HRD}}$	44	I	host interface read enable input (active LOW)
DMACK	45	I	DMA acknowledge input
$\overline{\text{IORDY/WAIT/HFBLB}}$	46	O	host interface wait output (active LOW); 3-state control
$\overline{\text{SCRST/STEN}}$	47	O	host interface status enable output ATAPI sub-CPU reset signal (active LOW)
$\overline{\text{DMARQ/DTEN}}$	48	O	ATAPI DMA request host interface data enable output (active LOW); 3-state control
$\overline{\text{IRQ/EOP/HFBC}}$	49	O	host interface end of process flag output ATAPI host interrupt request (active LOW); 3-state control
V _{DDD2}	50	–	digital supply voltage 2 (5 V)
HD0	51	I/O	host interface data bus input/output line 0
HD1	52	I/O	host interface database input/output line 1
HD2	53	I/O	host interface database input/output line 2
HD3	54	I/O	host interface data bus input/output line 3
HD4	55	I/O	host interface data bus input/output line 4
HD5	56	I/O	host interface data bus input/output line 5
HD6	57	I/O	host interface data bus input/output line 6
HD7	58	I/O	host interface data bus input/output line 7
DGND5	59	–	digital ground 5
HD8	60	I/O	host interface data bus input/output line 8
HD9	61	I/O	host interface data bus input/output line 9
HD10	62	I/O	host interface data bus input/output line 10
HD11	63	I/O	host interface data bus input/output line 11
HD12	64	I/O	host interface data bus input/output line 12
HD13	65	I/O	host interface data bus input/output line 13
HD14	66	I/O	host interface data bus input/output line 14
HD15	67	I/O	host interface data bus input/output line 15
DGND6	68	–	digital ground 6
$\overline{\text{DA0/CMD}}$	69	I	host interface data input (active LOW)/command select input host interface address line 0
DA1	70	I	ATAPI address line input 1
DA2/EJECT	71	I	ATAPI address line input 2
CS2/SELRQ	72	I	ATAPI chip select input 2
IOCS16	73	O	ATAPI 16-bit data select output
V _{DDD2}	74	–	digital supply voltage 2 (5 V)
RA0	75	O	buffer RAM address bus output line 0
RA1	76	O	buffer RAM address bus output line 1
RA2	77	O	buffer RAM address bus output line 2

Error correction and host interface IC for CD-ROM (ELM)

SAA7388

SYMBOL	PIN	I/O	DESCRIPTION
RA3	78	O	buffer RAM address bus output line 3
RA4	79	O	buffer RAM address bus output line 4
RA5	80	O	buffer RAM address bus output line 5

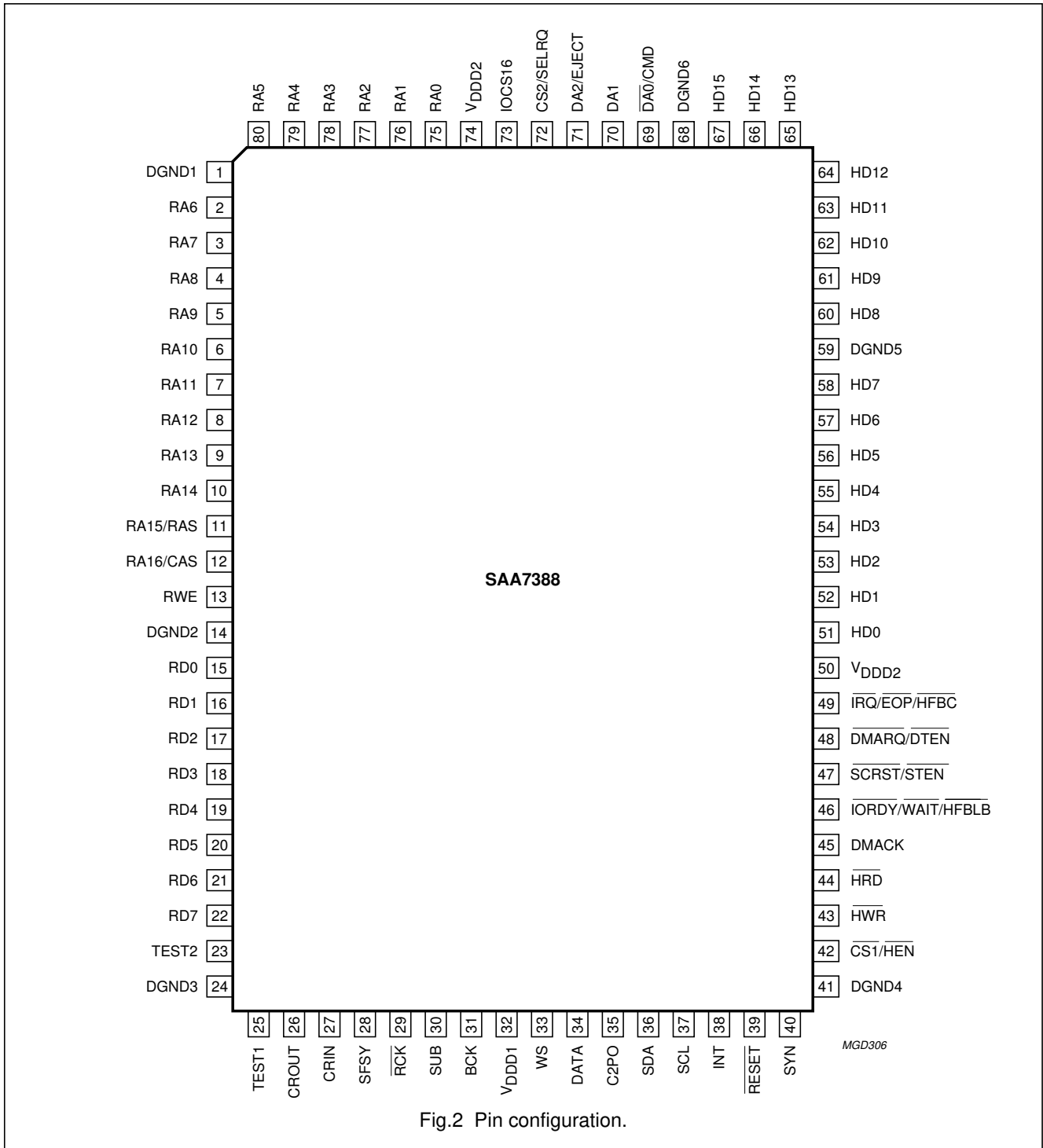

Fig.2 Pin configuration.

Error correction and host interface IC for CD-ROM (ELM)

SAA7388

6.1 Pin functions

6.1.1 RA0 TO RA14

External memory address signals.

6.1.2 RA16/CAS

External memory RA16 signal if SRAM or, CAS signal if DRAM.

6.1.3 RA15/RAS

External memory RA15 signal if SRAM or, RAS signal if DRAM.

6.1.4 RWE

Write output enable signal for external buffer memory. This is LOW when the SAA7388 wants to write data into the external memory.

6.1.5 RD0 TO RD7

External buffer memory bidirectional data signals.

6.1.6 SFSY

Frame sync for the Q-to-W subcode, indicates when P-channel is available by a HIGH-to-LOW transition. Frame 0 is also indicated by no transition on this line.

6.1.7 \overline{RCK}

In response to SFSY going LOW data is clocked into the SAA7388 before each rising edge using this clock output.

6.1.8 SUB

Q-to-W subcode is input in response to \overline{RCK} in 3-wire EIAJ mode or WS in "V4" mode compatible with the SAA7345.

6.1.9 BCK

Bit clock for the serial data input from the CD decoder.

6.1.10 WS

Word clock for the serial data input from the CD decoder.

6.1.11 DATA

Serial data input from the CD decoder. This may be either I²S-bus or EIAJ 16-bit format.

6.1.12 C2PO

Error flag from the CD decoder. A HIGH indicates that a byte has not been corrected by the C2 error corrector and therefore is not valid. This is taken into account by the SAA7388 error corrector.

6.1.13 SDA

Sub-CPU bidirectional data signal. This signal forms part of the 3-wire serial interface between the SAA7388 and the sub-CPU.

6.1.14 SCL

Sub-CPU sync signal. This signal forms part of the 3-wire serial interface between the SAA7388 and the sub-CPU. This signal is used to synchronize data transfers between the sub-CPU and the SAA7388.

6.1.15 INT

Sub-CPU interrupt signal. This active LOW output signals to the sub-CPU that the SAA7388 has an interrupt request.

6.1.16 \overline{RESET}

Forcing this input LOW resets the SAA7388.

6.1.17 SYN

Sub-CPU clock signal. This signal forms part of the 3-wire serial interface between the SAA7388 and the sub-CPU. This signal is the sub-CPU driven bit clock used to synchronize the signals on the SDA line.

6.1.18 $\overline{CS1}/\overline{HEN}$

In the ATAPI mode this is the host chip select 1 address signal. In the Sanyo and Oak compatibility modes setting this input LOW enables the host interface.

6.1.19 \overline{HWR}

This active LOW signal is the host write request.

6.1.20 \overline{HRD}

This active LOW signal is the host read request.

Error correction and host interface IC for CD-ROM (ELM)

SAA7388

6.1.21 DMACK

This signal is used in the ATAPI and Oak compatibility modes during DMA transfers. The host pulls this signal LOW in response to a $\overline{\text{DMARQ}}$ request to indicate that it is ready to transfer data.

If this signal is not being used then it must be pulled HIGH for SAA7388 to operate correctly.

6.1.22 $\overline{\text{ORDY}}/\overline{\text{WAIT}}/\overline{\text{HFBLB}}$

In the ATAPI mode this signal is negated to extend the host transfer cycle of any host register access. It is used in PIO transfers. When $\overline{\text{ORDY}}$ is not negated it is in a high-impedance state.

In the Sanyo compatibility mode the function of this signal depends on the SELRQ input. If SELRQ is HIGH then $\overline{\text{WAIT}}$ is set LOW to extend the host transfer cycle. If SELRQ is LOW then $\overline{\text{WAIT}}$ acts as the DRQ signal in a DMA transfer.

In the Oak compatibility mode this signal is the Host First Byte Latch signal. A rising edge on this signal is used to latch the first byte in a pseudo 16-bit DMA read. HFBLB can only be HIGH when pseudo 16-bit DMA transfer mode is selected.

6.1.23 $\overline{\text{SCRST}}/\overline{\text{STEN}}$

In the ATAPI or Oak compatibility mode this signal is pulled LOW to reset the sub-CPU in response to a reset command from the host.

In the Sanyo compatibility mode this signal is pulled LOW to signal to the host that status bytes are available for transfer.

6.1.24 $\overline{\text{DMARQ}}/\overline{\text{DTEN}}$

In the ATAPI or Oak compatibility mode this signal is asserted when the SAA7388 is ready to transfer data between the host and itself. In ATAPI single word and Oak DMA transfers this occurs at every word. In ATAPI multi-word DMA transfers this occurs at the start of the transfer.

In the Sanyo compatibility mode this signal is pulled LOW to signal to the host that data bytes are available for transfer.

6.1.25 $\overline{\text{IRQ}}/\overline{\text{EOP}}/\overline{\text{HFBC}}$

In the ATAPI mode this active HIGH signal indicates a host interrupt request. It is asserted when the sub-CPU writes to the ITRG register and is negated when the host reads the status register or writes to the command register.

In the Sanyo compatibility mode this signal is set LOW when the last data byte is transferred to or from the host.

In the Oak compatibility mode this is the Host First Byte Cycle output and is HIGH while the first byte in the pseudo 16-bit DMA transfer is accessed. It should be used to inhibit non-DMA transactions while the first byte is latched.

6.1.26 HD0 TO HD15

These are the bidirectional Host Data signals. In the Sanyo and Oak compatibility modes HD8 to HD15 are never used.

6.1.27 $\overline{\text{DA0}}/\text{CMD}$

In the ATAPI mode this is the host Data Address 0 signal. In the Sanyo and Oak compatibility modes this input selects between command or data transfers.

6.1.28 DA1

This is the ATAPI Data Address 1 signal.

6.1.29 DA2/ EJECT

In the ATAPI mode this is the Data Address 2 signal. In the Oak compatibility mode this is the door switch input pin. Its state is reflected in the TSTAT register.

6.1.30 CS2/SELRQ

In the ATAPI mode this is the Chip Select 2 signal. In the Oak and Sanyo compatibility mode this is the data transfer mode select input. It is used to select between PIO and DMA transfers.

6.1.31 IOCS16

This open-collector signal is used in the ATAPI mode to signal to the host that a 16-bit data port has been addressed. It is not activated during DMA transfers.

Error correction and host interface IC for CD-ROM (ELM)

SAA7388

7 FUNCTIONAL DESCRIPTION

The SAA7388 is comprised of four main blocks; a CD player interface, an error corrector, a host interface and a memory manager. These four blocks operate in parallel. All receive and send data to the buffer memory via the memory manager. A 36-kbit on-chip SRAM has been incorporated to allow high-speed data read operations for the error corrector.

The SAA7388 performs simultaneous data input buffering, error correction and host data transfer.

7.1 CD-DSP interface and data input

The input data is synchronized, decoded, and written to the buffer RAM. The input data format is software programmable.

The synchronization is achieved using a sync detector and a sync interpolator. The sync detector detects the sync pattern in every sector while the interpolator avoids sync loss when no sync is found. The detector and interpolator can be individually enabled and disabled under software control.

After decoding, each full sector of data (2352 bytes) comprising sync, header, sub-header and parity fields is written to the buffer RAM.

7.2 Error correction and EDC check

Error correction and detection is performed on each sector after it is written to the buffer RAM.

The SAA7388 buffers flag and data of sectors to be corrected in a 9-bit, 4096 words on-chip RAM memory. For erasure correction, no external 9-bit memory is required.

The standard error correction algorithm can be programmed, and supports mode 1 and mode 2 form 1 and form 2 discs.

After error correction, an electronic data check is executed.

When this EDC check is also complete, the sector header and sub-header is written to 8 header registers, and a decode complete interrupt is generated.

The microcontroller can then read the decoder status, the sector header and sub-header and the sector start address from the SAA7388.

7.3 Host interface

The host interface controls data transfers between the SAA7388 and an external microcontroller. The host interface can be programmed to operate in three modes. In the Sanyo compatibility mode the host interface is functionally compatible with the Sanyo LC89510 block decoder. In the Oak compatibility mode the host interface is functionally compatible with the Oak OTI-012 controller chip in enhanced mode.

In the ATAPI mode the interface meets the ATA Program Interface specification.

7.4 Subcode channel Q-to-W buffering

As well as buffering the main data, the SAA7388 can also be used to buffer R-to-W subcode data in buffer memory. Two buffer modes exist, raw mode and cooked mode. In the raw mode, data is written to an external RAM without any processing being performed. In the cooked mode, the Q-channel data is extracted, the Q-channel CRC is calculated, the R-to-W data is de-interleaved and the residues of each R-to-W frame are calculated. These residues make it easier to correct errors in the data.

7.5 External buffer memory

It is possible to use the SAA7388 with different external RAM memories. From 0 to 128 kbyte SRAMs or to 16-Mbit DRAMs are possible. Memories may be nibble or byte wide (allowing 2, 8 or 16 Mbits). Selection is performed under software control.

Unique to the SAA7388 is its ability to work with partly defective DRAMs. The SAA7388 offers the possibility to use a DRAM with bytes in error.

A RAM test is executed under microcontroller control. This RAM test indicates defective segments to the microcontroller which keeps a list of which bad sectors to avoid. The list can be stored in the buffer memory and/or the microcontroller's own memory.

7.6 Sub-CPU registers

This section describes the registers in the SAA7388. The operation of the registers varies depending on whether they are being read from or written to, and the host mode selected.

Error correction and host interface IC for CD-ROM (ELM)

SAA7388

Table 1 Sub-CPU registers during write

#	AR	NAME	BIT 7	BIT 6	BIT 5	BIT 4	BIT 3	BIT 2	BIT 1	BIT 0	
0	00000	ADATA/ SBOUT	ATAPI Data register/Status Byte Output register								
1	00001	IFCTRL	CMDIEN	DTEIEN	DECIEN	$\overline{\text{CMDBK}}$	$\overline{\text{DTWAI}}$	$\overline{\text{STWAI}}$	DOUTEN	SOUTEN	
2	00010	DBCL	Data Byte Count register bits 7 to 0								
3	00011	DBCH	Data Byte Count register bits 15 to 8								
4	00100	DACL	Data Address Counter register bits 7 to 0								
5	00101	DACH	Data Address Counter register bits 15 to 8								
6	00110	DTRG	Data Transfer Trigger register								
7	00111	DTACK	Data Transfer Acknowledge register								
8	01000	WAL	Write Address register bits 7 to 0								
9	01001	WAH	Write Address register bits 15 to 8								
10	01010	CTRL0	DECEN	lookahead	E01RQ	AUTOQ	ERAMRQ	WRRQ	ECCRQ	ENCODE	
11	01011	CTRL1	SYIEN	SYDEN	DSCREN	COWREN	MODRQ	FORMRQ	MBCKRQ	SHDREN	
12	01100	PTL	Block Pointer register bits 7 to 0								
13	01101	PTH	Block Pointer register bits 15 to 8								
14	01110										
15	01111	$\overline{\text{RESET}}$	reserved					HSEL			
16	10000	DACHH	mem	Data Address Counter register bits 20 to 16							
17	10001	WAHH	Write Address register bits 20 to 16								
18	10010	PTHH	Block Pointer register bits 20 to 16								
19	10011	SUB_L	Subcode Address register bits 7 to 0								
20	10100	SUB_H	Subcode Address register bits 9 and 8								
21	10101										
22	10110	INCNF	IISmode	div 1	div 0	QWmode	QWon	QWcook	RAM test	0	
23	10111	MEMS	0	PRIORITY		0	RFRSH	WIDTH	STATIC	CACHE	
24	11000	ASTAT	ATAPI Status register								
25	11001	ITRG	Host Interrupt Trigger register								
26	11010	ADRADR	ATAPI Drive Address register								
27	11011	ASAMT	ATAPI SAM TAG register								
28	11100	DTCTR	res.	DMAMODE	UDMA	SUBIEN	RDRV	TRANT			
29	11101	ADRSEL	ATAPI Drive Select register								
30	11110	AINTR	ATAPI Interrupt Reason register								
31	11111	AERR	ATAPI Error register								

Error correction and host interface IC for CD-ROM (ELM)

SAA7388

Table 2 Sub-CPU registers during read

#	AR	NAME	BIT 7	BIT 6	BIT 5	BIT 4	BIT 3	BIT 2	BIT 1	BIT 0
0	00000	APCMD/ COMIN	ATAPI packet command data/command input register							
1	00001	IFSTAT	$\overline{\text{CMDI}}$	$\overline{\text{DTEI}}$	$\overline{\text{DECI}}$	$\overline{\text{SUBI}}$	$\overline{\text{DTBSY}}$	$\overline{\text{SRSTI}}/\overline{\text{STBSY}}$	$\overline{\text{DTEN}}$	$\overline{\text{STEN}}$
2	00010	DBCL	Data Byte Count register bits 7 to 0							
3	00011	DBCH	Data Byte Count register bits 15 to 8							
4	00100	HEAD0	Minutes/ File Number							
5	00101	HEAD1	Seconds/ Channel Number							
6	00110	HEAD2	Frames/ Submode							
7	00111	HEAD3	Mode/ Coding Information							
8	01000	PTL	Block Pointer register bits 7 to 0							
9	01001	PTH	Block Pointer register bits 15 to 8							
10	01010	WAL	Write Address register bits 7 to 0							
11	01011	WAH	Write Address register bits 15 to 8							
12	01100	STAT0	CRCOK	ILSYNC	NOSYNC	LBLK	USHORT	SBLK	ERR	UCEB
13	01101	STAT1	MINERR	SECERR	BLKERR	MODERR	SH0ERR	SH1ERR	SH2ERR	SH3ERR
14	01110	STAT2	RMOD3	RMOD2	RMOD1	RMOD0	MODE	FORM	RFORM1	RFORM2
15	01111	STAT3	VALST		CBLK					
16	10000	PTHH	Block Pointer register bits 20 to 16							
17	10001	WAHH	Write Address register bits 20 to 16							
18	10010	SUB_L	Subcode Address register bits 7 to 0							
19	10011	SUB_H	Subcode Address register bits 9 and 8							
20	10100									
21	10101									
22	10110									
23	10111									
24	11000									
25	11001	HCON	Oak Host Configuration register							
26	11010	ACMD	ATAPI Command register							
27	11011	ASAMT	ATAPI SAM TAG register							
28	11100	ADCTR	ATAPI Device Control register							
29	11101	ADRSEL	ATAPI Drive Select register							
30	11110	AINTR	ATAPI Interrupt Reason register							
31	11111	AFEAT	ATAPI Features register							

Error correction and host interface IC for CD-ROM (ELM)

SAA7388

7.7 Register Descriptions

7.7.1 SBOUT/ADATA

This is a 12 byte FIFO used to transfer data from the sub-CPU to the host.

In the Sanyo and Oak compatibility mode writing to this register starts a status byte transfer. In this mode if the SOUTEN bit in the IFCTRL register has been set to logic 1, writing to the SBOUT register sets the STBSY bit to logic 0. If the STWAI bit is set to logic 0, \overline{STEN} is immediately set LOW to inform the host computer that the status byte is ready to be read from.

If the STWAI bit is set to logic 1 and the \overline{DTEN} bit in the IFSTAT register is also set to logic 1, both the \overline{STEN} pin and the STBSY will go LOW. However, if the STWAI bit is set to logic 0, and the \overline{DTEN} bit is set to logic 0, then \overline{STEN} is held HIGH until the DTEN bit goes HIGH, thereafter it goes LOW.

7.7.2 COMIN/ APCMD

During the ATAPI mode this register is used to read the program command sent by the host. The program command can only be received if the appropriate mode has been selected (see Table 22) and a data transfer has been started (see DTRG register).

During Sanyo and Oak compatibility modes this register is a 12 byte FIFO which is used to transfer commands from the host to the sub-CPU. If reading this register empties the command FIFO then CMDI is set to logic 1 and further reads from the register will return FFH.

7.7.3 IFCTRL

The IFCTRL register provides control over the host interface. Resetting the chip will clear all bits. In the ATAPI mode, only, bits 7 to 5 have any effect.

Table 3 IFCTRL register bits

BIT	NAME	DESCRIPTION
7	CMDIEN	Enable bits for CMDI, DTEI and DECI. These are interrupt masks, enabling/disabling the sub-CPU interrupt pin. They do not affect the bits in the IFSTAT register. If set to logic 1, the corresponding interrupt is enabled. It should be noted that these masks do not clear the interrupts.
6	DTEIEN	
5	DECIEN	
4	\overline{CMDBK}	Command break enable. If set to logic 0 then the command break function is enabled and if the host writes to the COMIN FIFO then any data or status byte transfers in progress will be terminated. If set to logic 1 then this operation is disabled. The data transfer interrupt DTEI is not generated by a command break.
3	\overline{DTWAI}	Data transfer \overline{WAIT} enable. Setting this bit to logic 0 enables the data \overline{WAIT} function. The data \overline{WAIT} function allows the SAA7388 to delay hardware execution of the data transfer until a status byte transfer has been completed. Disabling the data \overline{WAIT} function allows data transfers to take place independently of status byte transfers.
2	\overline{STWAI}	Status byte transfer \overline{WAIT} enable. This bit acts in a similar way to the \overline{DTWAI} bit except it controls the status \overline{WAIT} function. The status \overline{WAIT} function allows the SAA7388 to delay hardware execution of the status transfer until a data byte transfer has been completed. Disabling the data \overline{WAIT} function allows status transfers to take place independently of data transfers.
1	DOUTEN	Data output enable. DOUTEN enables/disables data transfers. When set to logic 0, all data transfers in progress are aborted.
0	SOUTEN	Status output enable. SOUTEN enables/disables status byte transfers. When set to logic 0, the status FIFO register is reset to empty and all status byte transfers in progress are aborted.

Error correction and host interface IC for CD-ROM (ELM)

SAA7388

7.7.4 IFSTAT

The IFSTAT register indicates the state of the host interface. In the ATAPI mode, only bits 7 to 2 have any meaning.

Table 4 IFSTAT register bits

BIT	NAME	DESCRIPTION
7	$\overline{\text{CMDI}}$	Command interrupt. In the ATAPI mode this bit is asserted when the host has written to the ATAPI command register (see ACMD register) and the drive is selected. It is also asserted when the host writes the execute drive diagnostic command (90H) to the ATAPI command register, regardless of whether the drive is selected. It is negated when the sub-CPU reads the ACMD register. In the Sanyo and Oak compatibility modes this bit is asserted while there are command bytes waiting in the COMIN FIFO. It is negated when the COMIN FIFO is empty.
6	$\overline{\text{DTEI}}$	Data transfer end interrupt. This bit is asserted at the end of data transfer. It is negated when the sub-CPU writes to the DTACK register. If the ATAPI mode is selected this bit is also asserted when a program command has been received and after a sub-CPU memory transfer.
5	$\overline{\text{DECI}}$	Decoder interrupt. This bit is asserted when a new sector is available. It is negated by reading the STAT3 register.
4	$\overline{\text{SUBI}}$	Subcode interrupt. This bit is asserted when a new subcode is available. It is negated by reading the SUB_H register.
3	$\overline{\text{DTBSY}}$	Data transfer busy. This bit indicates if a data transfer is taking place. It is asserted by writing to the DTRG register and is negated at the end of the transfer.
2	$\overline{\text{SRSTI/STBSY}}$	SRST bit interrupt/status transfer busy. In the ATAPI mode this bit is asserted when the host writes to the ATAPI device control register and sets the SRST bit. It is negated when the sub-CPU reads the ADCTR register. It should be noted that if this bit is asserted in the ATAPI mode then the sub-CPU interrupt will also be asserted. The $\overline{\text{SRSTI}}$ interrupt cannot be disabled. In the Sanyo and Oak compatibility modes this bit indicates if a status byte transfer is taking place. It is asserted by writing to the SBOU register and is negated when the host has emptied the status FIFO.
1	$\overline{\text{DTEN}}$	Data transfer and status transfer. These bits reflect the state of the $\overline{\text{DTEN}}$ and $\overline{\text{STEN}}$ pins in the Sanyo and Oak compatibility modes. They are updated at the end of a host read or write.
0	$\overline{\text{STEN}}$	

7.7.5 DBCL AND DBCH

The Data Byte Counter is used by the sub-CPU to control the number of bytes that are transferred in a data transfer. In the ATAPI mode all 16 bits are available while in the Sanyo and Oak compatibility modes only 15 bits are available with bit 7 of DBCH indicating the state of $\overline{\text{DTEI}}$ (see Table 4). During memory-to-host data transfers the data byte counter is decremented after every host read. During host-to-memory data transfers the data byte counter is decremented as data is written into external buffer memory.

7.7.6 DACL, DACH AND DACHH

This 21-bit write-only register is used to specify the external buffer address of the first byte of the data block to be transferred to the host.

Once the address has been set, it is incremented automatically as successive bytes are transferred with the host. It should be noted that pointer operation is asynchronous from host read/write operation. For this reason, counter increments are not coincident with host transfer operations.

Error correction and host interface IC for CD-ROM (ELM)

SAA7388

Bit 7 of the DACHH register specifies which memory is accessed. If the bit is clear then the address refers to the external memory, if the bit is set then the address refers to the 4 kbyte internal memory. The internal memory should not be accessed during error correction.

This register should be written to before each data transfer because its value will be undefined at the end of the previous transfer.

7.7.7 PTL, PTH AND PTHH

This register holds a 21-bit pointer to the external buffer memory address of the head of the current data block after correction.

The SAA7388 defines the minute byte in the header to be at the head of the block, and the 12 sync bytes at the tail of the block. Each block contained in the buffer is taken to be 2352 bytes.

The controller can transfer the decoded block back to the host by copying the address of this register to the DACL, DACH and DACHH pointers after a decoder interrupt.

When the WRRQ bit in the CTRL0 register is set to logic 1, this pointer is updated at the sync signal of every 2352 byte clocks.

7.7.8 WAL, WAH AND WAHH

These registers contain a 21-bit address of where raw data from the drive is written to the external buffer memory. The pointer is automatically incremented during data transfer. The pointer should only be read while drive data writes to the buffer are disabled. If WAHH is written to while drive data write is enabled, then the new WA value will be used

for the first byte of the next sector. The new pointer value is temporarily stored in the PT register. This cannot be read after WA has been written to.

7.7.9 DTRG

Writing to this register starts a data transfer. The data written is discarded.

7.7.10 DTACK

Writing to this register clears the \overline{DTEI} interrupt. The data written is discarded.

7.7.11 HEAD0, HEAD1, HEAD2 AND HEAD3

These registers are used to hold the header and the sub-header data of the current block.

To read the header data set, the SHDREN bit in the CTRL1 register is set to logic 0; to read the sub-header data, SHDREN is set to logic 1.

If sub-header is selected, the registers will normally hold data from bytes 20 to 23. However, if the error flag for one of these bytes is set, then the byte is taken from the first sub-header field. (bytes 16 to 19.)

The error flags for header and sub-header can be read from the STAT1 register. No error correction is performed on header or sub-header.

Header and sub-header registers are valid directly after decoder interrupt, and as long as the VALST bit in the STAT3 register is LOW. In all write modes they contain information on the block whose header is pointed to by PTL, PTH and PTHH.

Table 5 HEAD registers

SHDREN	REGISTER	CONTENTS
0	HEAD0	MINUTES (byte 12)
0	HEAD1	SECONDS (byte 13)
0	HEAD2	FRAMES (byte 14)
0	HEAD3	MODE (byte 15)
1	HEAD0	FILE NUMBER (byte 16 or 20)
1	HEAD1	CHANNEL NUMBER (byte 17 or 21)
1	HEAD2	SUBMODE NUMBER (byte 18 or 22)
1	HEAD3	CODING INFORMATION (byte 19 or 23)

Error correction and host interface IC for CD-ROM (ELM)

SAA7388

7.7.12 CTRL0

Resetting the chip sets all the bits in this register to logic 0.

Table 6 CTRL0 register

BIT	NAME	FUNCTION
7	DECEN	Disable decoding = 0; Enable decoding = 1. This bit enables/disables decoding functions. Disabling the decoding functions also disables the decoder interrupt.
6	lookahead	At interrupt PT, header refer to current block = 0; At interrupt PT, header refer to next block = 1. When this bit is set to logic 1 at decoder interrupt, CMA and header registers will give information on the next block instead of on the current block. The lookahead mode was included to provide support for bad RAMs, and to give the CPU better control on the blocks it wants to read.
5	E01RQ	Disable error correction of bytes = 0; Enable correction of CIRC mis-corrections = 1. Setting this bit to logic 0 instructs the error corrector not to correct bytes flagged as reliable by the CIRC error corrector.
4	AUTORQ	Disable automatic error correction = 0; Enable automatic error correction = 1. Requests automatic extraction of form bit during mode2 correction from sub-header data.
3	ERAMRQ	Disable erasure flag use = 0; Enable erasure flag use = 1. When set to logic 1, the SAA7388 will enable the use of erasure flag information for error correction. When set to logic 0, the SAA7388 will disable the use of erasure flag information for error correction. Use of erasure flags must be disabled SAA7388 when the CD-DSP does not output erasure flags and when the internal buffer RAM is disabled (which is necessary for repeat correction).
2	WRRQ	Disable data writes to the buffer and PTL updates = 0; Enables data writes to the buffer and PTL updates = 1. This bit enables/disables writes from the CD drive into the buffer. It also enables/disables pointer (PTL, PTH and PTHH) updates each time a block is received. When WRRQ is set to logic 1, data write will start from the first byte of the next block onwards. When WRRQ is set to logic 0, repeat correction is enabled. With WRRQ set to logic 0, the internal buffer RAM is disabled.
1	ECCRQ	Disable ECC correction = 0; Enable ECC correction = 1. When ECCRQ is set to logic 1 the blocks received by the SAA7388 will be error corrected before a decoder interrupt is generated. When ECCRQ is set to logic 0 no corrections are performed. The algorithm used is a QD, PD, QE, PE algorithm. In a first step, errors are corrected; in a second step, erasures are corrected. Correction data is read from the on-chip 36 kbit buffer memory.
0	ENCODE	Normal operation = 0; Test mode, do not use = 1, this bit must always be set to logic 0.

Error correction and host interface IC for CD-ROM (ELM)

SAA7388

Table 7 Error correction modes

DECEN	lookahead	WRRQ	ECCRQ	decoder mode
0	X	X	X	decoder disable; note 1
1	0	0	0	monitor only
1	0	0	1	repeat correction
1	0	1	0	write only
1	0	1	1	real-time correct, normal mode
1	1	1	0	write only, lookahead
1	1	1	1	real-time correct, lookahead

Note

- Where X = don't care.

7.7.13 CTRL1

The reset function clears all the flags in this register.

Table 8 CTRL1 register bits

BIT	NAME	FUNCTION
7	SYIEN	Disable sync interpolation = 0; Enable sync interpolation = 1. Enabling SYIEN prevents loss of synchronization when an error occurs in a sync pattern during data read.
6	SYDEN	Disable sync detection = 0; Enable sync detection = 1. Enabling SYDEN synchronizes the decoder with the sync pattern detected in the input data.
5	DSCREN	Descramble disable (audio) = 0; Descramble enable = 1. This bit enables/disables descrambling. Setting this bit to logic 0 allows reading of raw data on disc, even audio signals. This bit should be set to logic 1 for CROM data.
4	COWREN	CRC with error correction disabled = 0; Detection errors are corrected = 1. This bit enables/disables rewriting of error bytes in the buffer during error correction. Setting the bit to logic 0 allows CRC checks without error correction.
3	MODRQ	Mode 1 request = 0; Mode 2 request = 1. This bit discriminates Mode 1/Mode 2.
2	FORMRQ	Form 1 request = 0; Form 2 request = 1. This bit discriminates Mode 2/Form 1 and Mode 2/Form 2.
1	MBCKRQ	Disable mode check function = 0; Enable mode check function = 1. If the mode specified in the mode byte does not correspond with the raw data mode bit and this bit is set to logic 1 then error correction and detection is disabled.
0	SHDREN	Header data on registers Head0 to Head3 = 0; Sub-header data on registers Head0 to Head3 = 1. This bit toggles header and sub-header data between registers HEAD0 to HEAD3.

Error correction and host interface IC for CD-ROM (ELM)

SAA7388

7.7.14 STAT0

Resetting the chip clears all bits in this register.

Table 9 STAT0 register bits

BIT	NAME	FUNCTION
7	CRCOK	Cyclic redundancy check not OK = 0; Cyclic redundancy check OK = 1. Set by the EDC in accordance with the results of the CRC check.
6	ILSYNC	Sync pattern detected at word count 0 to 1174 or 1176 onwards = 1. This bit is set to logic 1 if the sync pattern in the incoming data is detected between word counts 0 and 1174 or 1176 to infinity, and the decoder has been retimed. Due to the presence of the cache RAM, it is necessary to stop error correction also when long blocks have been detected.
5	NOSYNC	Sync pattern inserted by sync interpolator not coincident with data sync = 1. This bit is set to logic 1, if the word counter reaches 1175 and no sync pattern has been detected in the input data. It indicates that the sync interpolator circuit inserted a sync.
4	LBLK	With SYIEN = 0, no sync found. Data block size has been extended = 1. This bit is set to logic 1, if the sync interpolator was switched off, and if the sync interpolator indicated that sync insertion was necessary. This condition causes the block length to be extended.
3		Reserved
2	SBLK	Short block indication = 1. This bit is set to logic 1 if the decoder is not retimed when a sync pattern is detected in an incorrect word location, and is ignored while the SYDEN bit is set to logic 0.
1	ERABLK	One or more bytes of the block are flagged with C2 flags = 1. This bit is set to logic 1 if one or more bytes of the current block contain erasures as indicated by the C2PO input.
0	UCEBLK	Uncorrectable errors in block = 1. This bit is set to logic 1 when one or more bytes of the current block remain in error after the error correction process.

7.7.15 STAT1

Resetting the chip clears all bits in this register.

The bits in this register indicate the reliability of data in the HEAD0 to HEAD3 registers. Bits MINERR, SECERR, BLKERR and MODERR indicate errors in the minutes, seconds, frames and mode bytes in the header of the current block. Bits SH0ERR to SH3ERR indicate errors in the respective bytes in the sub-header.

Table 10 STAT1 register bits

BIT 7	BIT 6	BIT 5	BIT 4	BIT 3	BIT 2	BIT 1	BIT 0
MINERR	SECERR	BLKERR	MODER	SH0ERR	SH1ERR	SH2ERR	SH3ERR

Error correction and host interface IC for CD-ROM (ELM)

SAA7388

7.7.16 STAT2

The bits MODE and FORM in this register indicate the mode, form and correction scheme of the current frame.

Table 11 STAT2 register bits

BIT 7	BIT 6	BIT 5	BIT 4	BIT 3	BIT 2	BIT 1	BIT 0
RMOD3	RMOD2	RMOD1	RMOD0	MODE	FORM	RFORM1	RFORM2

Table 12 MODE and FORM bits

MODE	FORM	SETTING
0	0	Mode 1
1	0	Mode 2, Form 1
X	1	Mode 2, Form 2 or ECC correction impossible

The Mode bit is always copied from the CTRL1 register. The Form information is determined by the AUTORQ bit in the CTRL0 register. When this bit is set to logic 0, the Form information is copied from the CTRL1 register. When this bit is set to logic 1 the Form information is copied from the Mode header byte.

If correction of the block was impossible, FORM will be set to logic 1 regardless of the requested correction. This will happen under the following circumstances:

- An illegally synchronized block (ILSYNC = 1 or LBLK = 1)
- A data block specified as Mode 2, Form 2, or detected as Mode 2, Form 2
- A Mode 2 submode byte error detected during processing
- A mode mismatch detected by the mode check function (MCHQRQ = 1)
- A mode byte error detected by the mode check function (MCHQRQ = 1).

The RFORM2, RFORM1 bits contain a preview of the form bit for the next frame

Table 13 RFORM2 and RFORM1 bits

RFORM1	RFORM2	MEANING
0	0	Form 0
0	1	Form 1
1	X	error in form byte

The RMOD3, RMOD2, RMOD1 and RMOD0 bits contain a preview of the next block MODE byte.

RMOD3 = bit7 # bit6 # bit5 # bit4 # bit3 # C2FLAG

RMOD2 = bit2 # C2FLAG

RMOD1 = bit1 # C2FLAG

RMOD0 = bit0 # C2FLAG

Error correction and host interface IC for CD-ROM (ELM)

SAA7388

Table 14 RMOD bits

RMOD3	RMOD2	RMOD1	RMOD0	MEANING
0	0	0	0	mode 0
0	0	0	1	mode 1
0	0	1	0	mode 2
0	0	1	1	mode 3
0	1	0	0	mode 4
0	1	0	1	mode 5
0	1	1	0	mode 6
0	1	1	1	mode 7
1	X	X	X	mode > 7 or error in mode byte (note 1)

Note

1. Where X = don't care.

7.7.17 STAT3

Reading this register clears any DECI interrupts.

Table 15 STAT3 register bits

BIT	NAME	MEANING
7	VALST	Registers associated with decoder interrupt valid = 0; Registers invalid = 1. This bit is a valid/invalid flag for the registers related to the decoder interrupt. After decoder interrupt, the sub-CPU must read out of all decoder registers before VALST goes HIGH.
6	–	–
5	CBLK	ECC not performed on current block = 0; ECC has been performed on current block = 1. This bit will go to logic 1 if ECC correction has been performed on the current block.
2	–	–
1	–	–
0	–	–

7.7.18 $\overline{\text{RESET}}$

Writing to this register resets the SAA7388 and initializes all of the registers. The data written determines the host mode of SAA7388.

Table 16 $\overline{\text{RESET}}$ register bits

BIT 7	BIT 6	BIT 5	BIT 4	BIT 3	BIT 2	BIT 1	BIT 0
reserved					HSEL		

The HSEL bits in the $\overline{\text{RESET}}$ register set the host interface mode. After a hardware reset the HSEL bits become 111. The SAA7388 will then wait until the sub-CPU writes to the $\overline{\text{RESET}}$ register and selects the host mode. After hardware reset 3-statable pins will be 3-state unless $\overline{\text{HRD}}$ is driven LOW.

Error correction and host interface IC for CD-ROM (ELM)

SAA7388

Table 17 HSEL bits

HSEL CONTENT			SELECTED HOST INTERFACE	DESCRIPTION
BIT 2	BIT 1	BIT 0		
0	0	0	Sanyo	Sanyo compatible mode
0	0	1	ATAPI	ATAPI Mode
0	1	0	Oak	Oak compatible mode
0	1	1	unknown host	all host bus pins 3-state, default after h/w reset
others			reserved	for future enhancements

7.7.19 SUB_L, SUB_H

This 10-bit register specifies the memory address of the subcode data block. This address will always be in the first 1 kbyte of memory.

7.7.20 INCNF

This register is used to specify the configuration of the input data path.

Table 18 INCNF register bits

BIT	NAME	DESCRIPTION
7	IISmode	I ² S-bus mode = 0; EIAJ serial interface mode = 1.
6	div1 ⁽¹⁾	If div1 and div0 = logic 0 then no oversampling (normal CDROM modes); If div1 = logic 0 and div0 = logic 1 then 2 times oversampling; If div1 = logic 1 and div0 = logic 0 then 4 times oversampling.
5	div0 ⁽¹⁾	If div1 and div0 = logic 0 then no oversampling (normal CDROM modes); If div0 = logic 1 and div1 = logic 0 then 2 times oversampling; If div1 = logic 0 and div1 = logic 0 then 4 times oversampling.
4	QWmode	Selection of Q-to-W input format. Logic 0 = V4 mode; logic 1 = EIAJ mode.
3	QWon	Q-to-W interface enable. Logic 0 = off; logic 1 = on.
2	QWcook	Q-to-W interface cooking enable. Logic 0 = cooked mode; logic 1 = RAW mode.
1	RAMtest	External RAM test mode. Logic 0 = normal operation; logic 1 = RAM test mode.
0	–	–

Note

- For subcode Q-to-W recovery, the BCK clock is used as a timing reference. It is possible to recover the Q-to-W subcode using the SAA7388, while at the same time the serial interface is programmed in oversampling mode for a DAC. Under such circumstances, it is necessary to tell the SAA7388 the oversampling factor.

Error correction and host interface IC for CD-ROM (ELM)

SAA7388

7.7.21 MEMS

This register is used to specify the configuration of the external buffer memory.

Table 19 MEMS register bits

BIT	NAME	DESCRIPTION
7		
6	PRIORITY	Host priority access. These bits specify the external memory accesses priority.
5	PRIORITY	
4	–	–
3	RFRSH	DRAM refresh rate. Setting this bit specifies a DRAM refresh rate of clock frequency/400. Clearing this bit specifies a rate of clock frequency/200. With a 33 MHz clock this bit should be set, while with a 16 MHz clock the bit should be clear.
2	WIDTH	DRAM width select. This bit should be set if the external DRAM has a nibble wide data bus. If the data bus is byte wide then this bit should be clear.
1	STATIC	SRAM/DRAM select. If the external buffer memory is DRAM then this bit should be cleared. If the memory is SRAM this bit should be set.
0	CACHE	CACHE memory select. If the internal cache is available then this bit should be clear. Setting this bit to logic 1 indicates that there is no internal cache memory.

Table 20 Host priority access

PRIORITY BITS		ACCESS
BIT 6	BIT 5	
0	0	only one host access has highest priority
0	1	two successive host accesses have highest priority
1	0	three successive host accesses have highest priority
1	1	four successive host accesses have highest priority

7.7.22 ITRG

In the ATAPI mode writing to this register generates a host interrupt. This interrupt is cleared when the host reads the ATAPI status register or writes to the ATAPI command register.

In the Sanyo and Oak compatibility modes writing to this register has no effect.

7.7.23 ASTAT

This write only register is only available in the ATAPI mode; it is the ATAPI status register and is used to transfer status information to the ATAPI host.

Bit 7 of this register is the BSY bit and this is set by the SAA7388 whenever;

- SAA7388 is the selected drive and the host writes to the command register (ACMD)
- The host writes the execute drive diagnostic command (90H) to the command register
- The host writes to the device control register (ADCTR) and sets the SRST bit
- There is a hardware reset.

On reset this register is set to (80H).

Error correction and host interface IC for
CD-ROM (ELM)

SAA7388

7.7.24 ACMD

This read only register is only available in the ATAPI mode; it is the ATAPI command register and is used to transfer commands from the host to the SAA7388.

The CMDI interrupt is generated when;

- The host writes to this register while the SAA7388 is the selected drive (the DRV bit in the ADRSEL register is equal to the RDRV bit in the DTCTR register)
- The host writes the execute drive diagnostic command (90H) to this register.

The BSY bit in the ASTAT register is also set under these conditions. If the sub-CPU reads this register while CMDI is asserted then it will be negated.

7.7.28 ADRSEL

Table 21 ADRSEL register bits

BIT 7	BIT 6	BIT 5	BIT 4	BIT 3	BIT 2	BIT 1	BIT 0
1	1	1	DRV	–	–	–	–

Bit 4 of this register is the DRV bit. When this bit is the same as the RDRV bit in the DTCTR register then the SAA7388 will be the selected ATAPI drive and will respond to host commands and produce host interrupts.

7.7.29 AINTR

This register is the ATAPI Interrupt Reason register.

7.7.30 AFEAT

This read only register is the ATAPI Features register.

7.7.31 AERR

This write only register is the ATAPI Error register.

7.7.25 ADRADR

This write only register is the ATAPI Drive Address register.

7.7.26 ASAMT

This register is the ATAPI Sector Number register.

7.7.27 ADCTR

This read only register is the ATAPI Device Control register. If the SRSTI interrupt is asserted then reading this register will negate it.

7.7.32 DTCTR - DATA TRANSFER CONTROL REGISTER

The DTCTR register controls data transfer flows in the host Interface block. On reset this register is cleared to all zeros except for the RDRV bit which is set to logic 1. This means that the SAA7388 will be set to drive 1 after a reset.

There are several possible data transfers through the SAA7388 host Interface block and these are selected using the TRANT bits. The transfers are described in the Table 23.

Error correction and host interface IC for
CD-ROM (ELM)

SAA7388

Table 22 Data transfer control register bits

BIT	FLAG	VERBOSE	DESCRIPTION
7	res.	–	reserved
6	DMAMODE	DMA Mode Select	logic 0 = single-word; logic 1 = multi-word
5	UDMA	Use DMA	logic 1 = DMA; logic 0 = PIO
4	SUBIEN	SUBI Enable	logic 1 = interrupt enabled
3	RDRV	Real Drive Select	ATAPI drive number
2	TRANT	–	see Table 23
1			
0			

Table 23 TRANT transfer bits

TRANT			FROM	TO	MAXIMUM BYTES	NOTES
BIT 2	BIT 1	BIT 0				
0	0	0	memory	host	65535 (ATAPI)	DMA and PIO
					32767 (Sanyo)	
0	0	1	host	memory	65535 (ATAPI)	DMA and PIO
					32767 (Sanyo)	
0	1	0	sub-CPU	memory	–	–
0	1	1	memory	sub-CPU	–	–
1	0	0	host	sub-CPU	12	PIO; DBC not used, always 12 bytes
1	0	1	sub-CPU	host	12	DMA and PIO
1	1	x	reserved	reserved	reserved	–

In the Sanyo and Oak compatibility modes the only transfers are memory-to-host, host-to-memory, sub-CPU-to-memory, and memory-to-sub-CPU. Setting the TRANT bits to any other settings while in these host modes will cause undefined results.

Error correction and host interface IC for CD-ROM (ELM)

SAA7388

7.8 Sub-CPU interface

The sub-CPU interface is a 3-wire synchronous serial protocol. The interface uses three signals; SYN is used as a synchronization signal, SDA is the bidirectional open-collector data signal and SCL is the bit clock.

The start of a command is signalled by a pulse on the SYN input. After this pulse an 8-bit address byte will be sent by the sub-CPU. The format of this address byte is given in Table 24.

Table 24 Address byte format

BIT	NAME	DESCRIPTION
7	device select	If this bit is clear then the command will be for the SAA7388 otherwise the command is for another device and the SAA7388 will not respond.
6	address mode	This bit controls the auto-increment function. After every byte has been read from or written to the SAA7388 the address register is updated so that it is not necessary to re-send the address to read or write the following byte. The way the address register is updated is determined by the address mode bit. If the address mode bit is logic 0 then the address register will increment by 1 if it is currently in the range 1 to 14 or 16 to 30. If the address register is currently 15 or 31 then it will update to 0, if the address register is at logic 0 then it will remain at address 0. If the address mode bit is logic 1 then the address register will update in the following sequences; Read: APCMD/COMIN -> APCMD/COMIN, IFSTAT -> DBCL -> DBCH -> HEAD0 -> HEAD1 -> HEAD2 -> HEAD3 -> PTL -> PTH -> PTHH -> WAL -> WAH -> WAHH -> STAT0 -> STAT1 -> STAT2 -> STAT3 -> APCMD/COMIN, ACMD -> ASMAT -> ADCTR -> ADRSEL -> AINTR -> AFEAT -> APCMD/COMIN. Write: ADATA/SBOUT -> ADATA/SBOUT, IFCTRL -> DBCL -> DBCH -> DACL -> DACH -> DACHH -> DTRG -> DTACK -> WAL -> WAH -> WAHH -> CTRL0 -> CTRL1 -> PTL -> PTH -> PTHH -> SUB_L -> SUB_H -> 21 -> INCNF -> MEMS -> ASTAT -> ITRG -> ADRADR -> ASAMT -> DTCTR -> ADRSEL -> AINTR -> AERR -> ADATA/SBOUT.
5	register number	This is the address that is loaded into the address register and determines which register is accessed.
4		
3		
2		
1		
0	R/ \overline{W}	If this bit is set to logic 0 then the sub-CPU will send one or more data bytes after the address byte. This data will be loaded into the specified registers. If this bit is set to logic 1 then after sending the address byte the sub-CPU will clock out the contents of one or more registers.

Error correction and host interface IC for
CD-ROM (ELM)

SAA7388

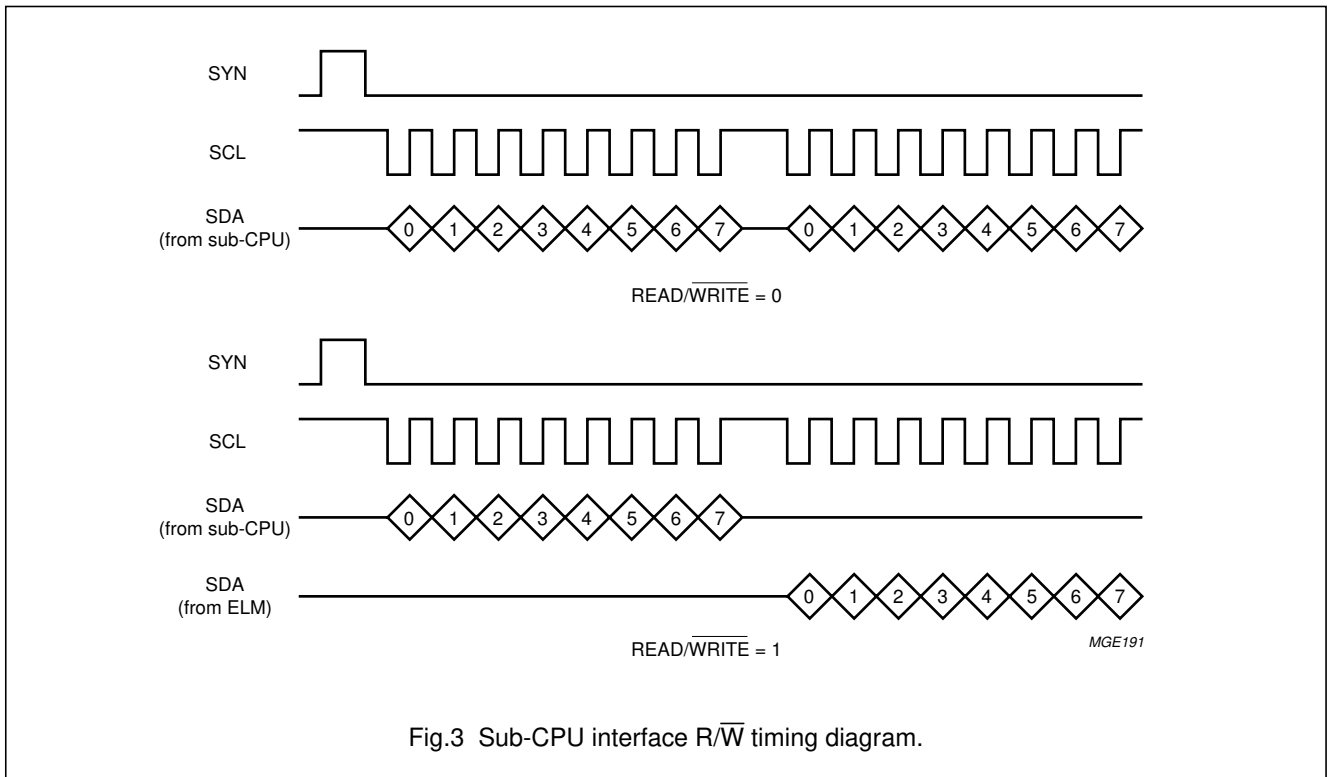

Fig.3 Sub-CPU interface R/W timing diagram.

7.9 Host registers

7.9.1 SANYO COMPATIBILITY MODE

Table 25 Sanyo compatibility mode

$\overline{\text{HEN}}$	CMD	$\overline{\text{HRD}}$	$\overline{\text{HWR}}$	OPERATION
0	0	1	0	write COMIN
0	0	0	1	read SBOU
0	1	1	0	write data
0	1	0	1	read data
1	X	X	X	none (note 1)

Note

1. Where X = don't care.

7.9.1.1 COMIN

This is a 12-byte FIFO used for sending commands from the host to the sub-CPU. When the host writes to the COMIN register a sub-CPU CMDI interrupt is generated to indicate there are bytes in the COMIN FIFO. This is cleared when the sub-CPU empties the FIFO. If the host writes to the register when the FIFO is full then the command is ignored.

If the host writes to this register when the CMDBK bit in the IFCTRL register is asserted then this will terminate any data or status byte transfers that are in progress.

7.9.1.2 SBOU

This is a 12 byte FIFO used to transfer status bytes from the sub-CPU to the host. The host should only access this register when the STEN pin is LOW indicating that there are status bytes available.

Error correction and host interface IC for CD-ROM (ELM)

SAA7388

7.9.1.3 Data Transfer

The other registers are used for data transfers. These can only occur when the sub-CPU has enabled a data transfer. This will be indicated to the host by the $\overline{\text{DTEN}}$ pin being LOW.

7.9.2 OAK COMPATIBILITY MODE

Table 26 Oak compatibility mode

DMACK	$\overline{\text{HEN}}^{(1)}$	DA1 ⁽¹⁾	$\overline{\text{DA0}}^{(1)}$	$\overline{\text{HRD}}^{(1)}$	$\overline{\text{HWR}}^{(1)}$	DATA TRANSFER SELECTED ⁽¹⁾	OPERATION
1	0	0	0	1	0	NO	write COMIN
1	0	0	0	0	1	NO	read SBOU
1	0	0	0	1	0	YES	write data
1	0	0	0	0	1	YES	read data
1	0	0	1	1	0	X	$\overline{\text{RESET}}$ sub-CPU
1	0	0	1	0	1	X	read TSTAT
1	0	1	0	1	0	X	write HCON
1	1	X	X	X	X	X	none
0	X	X	X	1	0	X	write DMA data
0	X	X	X	0	1	X	read DMA data

Note

- Where X = don't care.

Data transfer is selected when the transfer type is non-DMA, the sub-CPU has started a data transfer and the DTS bit in the HCON register has not been asserted.

DMA transfer is selected using the HCON register.

The COMIN and SBOU registers are similar to the same registers in the Sanyo compatibility mode.

7.9.2.1 $\overline{\text{RESET}}$ Sub-CPU

Writing to this register causes the $\overline{\text{SCRST}}$ pin to go LOW for several clock periods. The SAA7388 registers are not affected.

7.9.2.2 TSTAT

Table 27 TSTAT register bits

BIT 7	BIT 6	BIT 5	BIT 4	BIT 3	BIT 2	BIT 1	BIT 0
1	1	EJECT	$\overline{\text{WAIT}}$	$\overline{\text{EOP}}$	$\overline{\text{STEN}}$	$\overline{\text{DTEN}}$	DRQ

This is the host Transfer Status Register. The EJECT bit reflects the state of the EJECT pin. Bits $\overline{\text{EOP}}$, $\overline{\text{STEN}}$ and $\overline{\text{DTEN}}$ have the same operation as the equivalent pins in the Sanyo compatibility mode. Bit $\overline{\text{WAIT}}$ is the same as the Sanyo mode $\overline{\text{WAIT}}$ pin when non-DMA transfer is selected otherwise it is logic 1. Bit DRQ is the same as the Sanyo mode $\overline{\text{WAIT}}$ pin when DMA transfer is selected otherwise it is logic 0.

Error correction and host interface IC for CD-ROM (ELM)

SAA7388

7.9.2.3 HCON

Table 28 HCON register bits

BIT 7 ⁽¹⁾	BIT 6 ⁽¹⁾	BIT 5 ⁽¹⁾	BIT 4 ⁽¹⁾	BIT 3	BIT 2	BIT 1	BIT 0
X	X	X	X	DTS	SDRQ	LOHI	DMA16

Note

- Where X = don't care.

This is the host configuration register. Resetting SAA7388 clears this register.

Bit DTS is the suspend transfer bit. Setting this bit HIGH suspends non-DMA transfers and allows the host to access the COMIN and SBOU registers. During DMA transfers this bit has no effect.

If SDRQ is LOW and the SELRQ pin is LOW then DMA transfer is selected otherwise non-DMA transfer is selected.

The pseudo 16-bit DMA read transfer is selected by setting bit DMA16 HIGH. DMA transfer must also be selected for this mode to operate. host writes are always 8-bit and are not affected by this bit.

The LOHI bit when HIGH causes the pseudo 16-bit DMA transfer to be a LOW byte followed by a HIGH byte. Setting it LOW causes the sequence to be a HIGH byte followed by a LOW byte. If the 16-bit DMA mode is not selected then this bit has no effect.

7.9.3 ATAPI MODE

The following registers are accessible by the ATAPI host. Most of these registers are identical to the sub-CPU registers with the same name.

Table 29 ATAPI registers

ADDRESS					WRITE \overline{HWR}	READ \overline{HRD}	WIDTH
CS2	$\overline{CS1}$	DA2	DA1	$\overline{DA0}$			
1	0	0	0	0	DATA	DATA	16
1	0	0	0	1	AFEAT	AERR	8
1	0	0	1	0	AINTR	AINTR	8
1	0	0	1	1	ASAMT	ASAMT	8
1	0	1	0	0	DBCL	DBCL	8
1	0	1	0	1	DBCH	DBCH	8
1	0	1	1	0	ADRSEL	ADRSEL	8
1	0	1	1	1	ACMD	ASTAT	8
0	1	1	1	0	ADCTR	Alt Status	8
0	1	1	1	1	reserved	ADRADR	8

Error correction and host interface IC for CD-ROM (ELM)

SAA7388

Table 30 Description of registers

REGISTER	DESCRIPTION
DATA	This is a 16-bit register and is used for transferring data to and from the host. This should only be performed after the Sub-CPU has initiated the data transfer.
AFEAT	This is the ATAPI Features register.
AERR	This is the ATAPI Error register.
AINTR	This is the ATAPI Interrupt Reason register.
ASAMT	This is the ATAPI Sector Count register.
DBCL and DBCH	These are the ATAPI Byte Count registers.
ADRSEL	This is the ATAPI Drive Select register (see Table 31). Bit 4 of this register is the DRV bit. When this bit is the same as the RDRV bit in the DTCTR register then SAA7388 will be the selected ATAPI drive and will respond to commands and produce interrupts. The host Interrupt pin will also be enabled when SAA7388 is the selected drive.
ACMD	This is the ATAPI Command register. A CMDI interrupt is generated when the host writes to this register while SAA7388 is the selected drive (the DRV bit in ADRSEL is equal to the RDRV bit in DTCTR) and when the host writes the execute drive diagnostic command (90H) to this register. If a host interrupt is asserted then it will be cleared by writing to this register.
ASTAT	This is the ATAPI Status register. Bit-7 is the BSY bit and this will be set whenever the host writes to the ACMD register and SAA7388 is the selected drive, when the host writes the execute drive diagnostic command (90H) to the ACMD register, when the host writes to the ADCTR register and sets the SRST bit and when there is a hardware reset. If a host interrupt is asserted then it will be cleared by writing to this register.
ALT STATUS	This is the ATAPI Alternative Status register. This is identical to the ASTAT register except reading this register does not negate the host interrupt.
ADCTR	This is the ATAPI Device Control register (see Table 32)
ADRADR	This is the ATAPI Drive Address register. Bit 7 of this register is high impedance.

Table 31 ADRSEL register bits

BIT 7	BIT 6	BIT 5	BIT 4	BIT 3	BIT 2	BIT 1	BIT 0
1	1	1	DRV	–	–	–	–

Table 32 ADCTR register bits

BIT 7	BIT 6	BIT 5	BIT 4	BIT 3	BIT 2	BIT 1	BIT 0
reserved				1	SRST	nIEN	0

Setting the SRST bit HIGH causes a SRSTI interrupt and the BSY bit to be set.

Bit nIEN is used to enable or disable the host interrupt. When nIEN is logic 0 and the drive is selected then the host interrupt pin will be enabled. If nIEN is logic 1 or the drive is not selected then the host interrupt pin will be in a high-impedance state.

Error correction and host interface IC for CD-ROM (ELM)

SAA7388

7.10 CD-DSP Timings

The timings are for 8 times speed with a 33 MHz crystal.

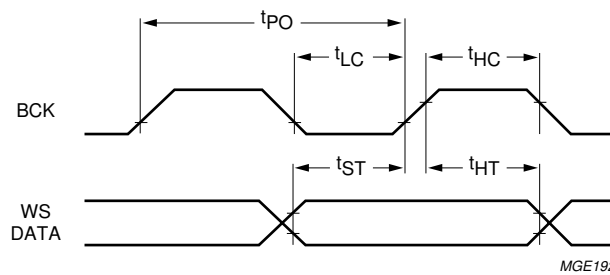
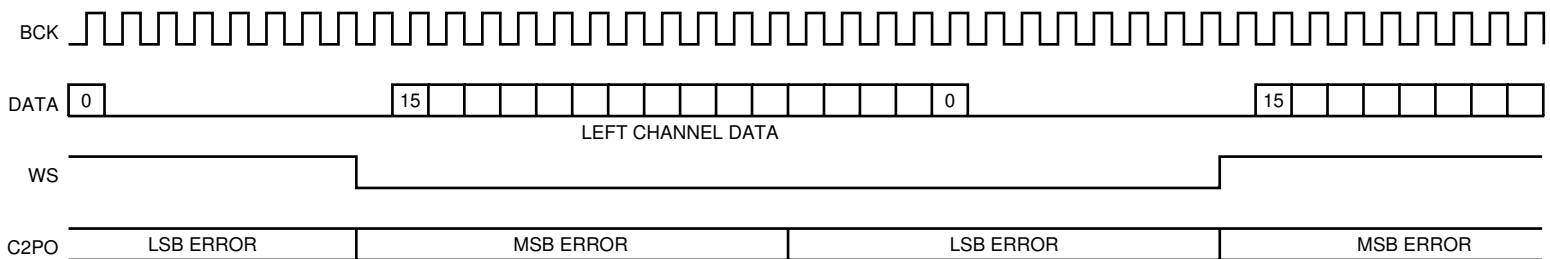

Fig.4 CD-DSP Interface Timing.

Error correction and host interface IC for
CD-ROM (ELM)

SAA7388



MGE193

C2PO is sampled coincident with bits 14 and 12 of the incoming DATA.

Fig.5 Philips I²S-bus data format.

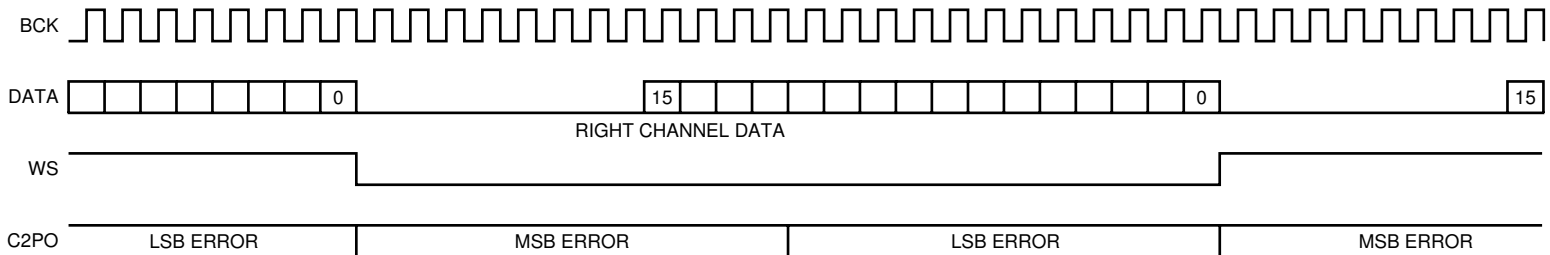

MGE194

C2PO is sampled coincident with bits 14 and 12 of the incoming DATA.

Fig.6 EIAJ data format.

Error correction and host interface IC for CD-ROM (ELM)

SAA7388

8 LIMITING VALUES

In accordance with the Absolute Maximum Rating System (IEC 134).

SYMBOL	PARAMETER	CONDITIONS	MIN.	MAX.	UNIT
V _{DDD1}	digital supply voltage 1	note 1	-0.5	+4.5	V
V _{DDD2}	digital supply voltage 2	note 1	-0.5	+6.5	V
V _{I(max)}	maximum input voltage on any input		-0.5	V _{DDD} + 0.5	V
V _O	output voltage on any output		-0.5	+6.5	V
I _O	output current (continuous)		-	20	mA
I _{IK}	DC input diode current (continuous)		-	20	mA
P _{diss}	power dissipation		-	400	mW
T _{stg}	storage temperature		-55	+125	°C
T _{amb}	operating ambient temperature		0	+70	°C

Note

1. All V_{DD} and V_{SS} connections must be made externally to the same associated power supply.

9 THERMAL CHARACTERISTICS

SYMBOL	DESCRIPTION	VALUE	UNIT
R _{thj-a}	thermal resistance from junction to ambient in free air	55	K/W

Error correction and host interface IC for CD-ROM (ELM)

SAA7388

10 CHARACTERISTICS

$V_{DD1} = 3.0$ to 3.6 V; $V_{DD2} = 4.5$ to 5.5 V; $V_{SS} = 0$; $T_{amb} = 0$ to 70 °C; unless otherwise stated.

SYMBOL	PARAMETER	CONDITIONS	MIN.	TYP.	MAX.	UNIT
Supply						
V_{DD1}	digital supply voltage 1		3.0	3.3	3.6	V
V_{DD2}	digital supply voltage 2		4.5	5.0	5.5	V
I_{DD}	supply current	$V_{DD1} = 3.3$ V; $V_{DD2} = 5$ V	–	60	–	mA
I_{DDq}	quiescent supply current	$V_{DD1} = 3.3$ V; $V_{DD2} = 5$ V	–	100	–	mA
Digital inputs						
INPUT: $\overline{\text{RESET}}$ (CMOS INPUT)						
$V_{th(r)}$	switching threshold rising		–	–	$0.8V_{DD2}$	V
$V_{th(f)}$	switching threshold falling		$0.2V_{DD2}$	–	–	V
V_{hys}	hysteresis voltage		–	$0.33V_{DD2}$	–	V
C_i	input capacitance		–	–	10	pF
t_{RW}	$\overline{\text{RESET}}$ pulse width	$\overline{\text{RESET}}$ only	1	–	–	μs
INPUTS: SFSY, SUB, BCK, WS, DATA, C2PO, SCL, $\overline{\text{CS1/HEN}}$, $\overline{\text{HWR}}$, HRD, DA0/CMD, DMACK/SELRQ, DA1, DA2/EJECT, CS2 AND SYN (CMOS INPUT)						
V_{IL}	LOW level input voltage		–0.3	–	$0.3V_{DD2}$	V
V_{IH}	HIGH level input voltage		$0.7V_{DD2}$	–	$V_{DD2} + 0.3$	V
I_{Li}	input leakage current	$V_i = 0 - V_{DD2}$	–10	–	+10	μA
C_i	input capacitance		–	–	10	pF
INPUTS: TEST1 AND TEST2 (CMOS INPUT)						
V_{IL}	LOW level input voltage		–0.3	–	$0.3V_{DD2}$	V
V_{IH}	HIGH level input voltage		$0.7V_{DD2}$	–	$V_{DD2} + 0.3$	V
R_{pd}	input pull-down resistance	$V_i = V_{DD2}$	–	50	–	k Ω
C_i	input capacitance		–	–	10	pF
Digital outputs						
OUTPUTS: RA0, RA1 TO RA14, RA15/RAS, RA16/CAS, RWE, $\overline{\text{RCK}}$ AND $\overline{\text{SCRST/STEN}}$						
V_{OL}	LOW level output voltage	$I_{OL} = 1$ mA	0	–	0.4	V
V_{OH}	HIGH level output voltage	$I_{OH} = -1$ mA	$V_{DD2} - 0.4$	–	V_{DD2}	V
C_L	load capacitance		–	–	25	pF
t_r	output rise time	$C_L = 20$ pF; 0.8 to $(V_{DD2} - 0.8)$	–	–	10	ns
t_f	output fall time	$C_L = 20$ pF; $(V_{DD2} - 0.8)$ to 0.8	–	–	10	ns

Error correction and host interface IC for CD-ROM (ELM)

SAA7388

SYMBOL	PARAMETER	CONDITIONS	MIN.	TYP.	MAX.	UNIT
OPEN-DRAIN OUTPUTS; INT, IOCS16						
V _{OL}	LOW level output voltage	V _{DD2} = 4.5 to 5.5 V; I _{OL} = 1 mA	0	–	0.4	V
I _{OL}	LOW level output current		–	–	2	mA
C _L	load capacitance		–	–	25	pF
t _f	output fall time	C _L = 20 pF; 0.8 – (V _{DD2} – 0.8)	–	–	20	ns
3-state outputs						
OUTPUTS: $\overline{\text{IRQ/EOP/HFBC}}$, $\overline{\text{IRDY/WAIT/HFBLB}}$ AND $\overline{\text{DMARQ/DTEN}}$						
V _{OL}	LOW level output voltage	I _{OL} = 1 mA	0	–	0.4	V
V _{OH}	HIGH level output voltage	I _{OH} = –1 mA	V _{DD2} – 0.4	–	V _{DD2}	V
C _L	load capacitance		–	–	50	pF
t _r	output rise time	C _L = 20 pF; 0.8 – (V _{DD2} – 0.8)	–	–	15	ns
t _f	output fall time	C _L = 20 pF; (V _{DD2} – 0.8) – 0.8	–	–	15	ns
I _{LZ}	3-state leakage current	V _i = 0 – V _{DD2}	–10	–	+10	μA
Digital inputs/outputs						
INPUTS AND OUTPUTS: RD0 TO RD7						
V _{OL}	LOW level output voltage	I _{OL} = 1 mA	0	–	0.4	V
V _{OH}	HIGH level output voltage	I _{OH} = –1 mA	V _{DD2} – 0.4	–	V _{DD2}	V
V _{IL}	LOW level input voltage		–0.3	–	0.3V _{DD2}	V
V _{IH}	HIGH level input voltage		0.7V _{DD2}	–	V _{DD2} + 0.3	V
C _L	load capacitance		–	–	50	pF
t _r	output rise time	C _L = 20 pF; 0.8 – (V _{DD2} – 0.8)	–	–	15	ns
t _f	output fall time	C _L = 20 pF; (V _{DD2} – 0.8) – 0.8	–	–	15	ns
I _{LZ}	3-state leakage current	V _i = 0 – V _{DD2}	–10	–	+10	μA
INPUTS AND OUTPUTS: HD0 TO HD15						
V _{OL}	LOW level output voltage	I _{OL} = 1 mA	0	–	0.4	V
V _{OH}	HIGH level output voltage	I _{OH} = –1 mA	V _{DD2} – 0.4	–	V _{DD2}	V
V _{IL}	LOW level input voltage		–0.3	–	0.3V _{DD2}	V
V _{IH}	HIGH level input voltage		0.7V _{DD2}	–	V _{DD2} + 0.3	V
C _L	load capacitance		–	–	100	pF
t _r	output rise time	C _L = 20 pF; 0.8 – (V _{DD2} – 0.8)	–	–	5	ns
t _f	output fall time	C _L = 20 pF; (V _{DD2} – 0.8) – 0.8	–	–	5	ns
I _{LZ}	3-state leakage current	V _i = 0 – V _{DD2}	–10	–	+10	μA

Error correction and host interface IC for CD-ROM (ELM)

SAA7388

SYMBOL	PARAMETER	CONDITIONS	MIN.	TYP.	MAX.	UNIT
INPUT AND OUTPUT: SDA						
V_{IL}	LOW level input voltage		-0.3	-	$0.3V_{DD2}$	V
V_{IH}	HIGH level input voltage		$0.7V_{DD2}$	-	$V_{DD2} + 0.3$	V
I_{LZ}	3-state leakage current	$V_i = 0 - V_{DD2}$	-10	-	+10	μA
C_i	input capacitance		-	-	10	pF
V_{OL}	LOW level output voltage	$I_{OL} = 1 \text{ mA}$	0	-	0.4	V
V_{OH}	HIGH level output voltage	$I_{OH} = -1 \text{ mA}$	$V_{DD2} - 0.4$	-	V_{DD2}	V
I_{OL}	LOW level output current		-	-	4	mA
C_L	load capacitance		-	-	100	pF
t_r	output rise time	$C_L = 25 \text{ pF};$ $0.8 - (V_{DD2} - 0.8)$	-	-	5	ns
t_f	output fall time	$C_L = 25 \text{ pF};$ $(V_{DD2} - 0.8) - 0.8$	-	-	5	ns
Crystal oscillator						
INPUT: CRIN (EXTERNAL CLOCK)						
I_{LI}	input leakage current		-10	-	+10	μA
C_i	input capacitance		-	-	10	pF
OUTPUT: CROUT						
f_{xtal}	crystal frequency		15.2	48	50.4	MHz
g_m	mutual conductance at start-up		-	4	-	mA/V
R_O	output resistance at start-up		-	11	-	k Ω
C_{fb}	feedback capacitance		-	-	5	pF
C_o	output capacitance		-	-	10	pF

Error correction and host interface IC for CD-ROM (ELM)

SAA7388

11 TIMING CHARACTERISTICS

SYMBOL	PARAMETER	CONDITIONS	MIN.	TYP.	MAX.	UNIT
CD-DSP timing; see Figs 4, 5 and 6; note 1						
INPUT: BCK						
t_{PO}	input clock period		40	–	1050	ns
t_{HC}	clock HIGH time		14	–	–	ns
t_{LC}	clock LOW time		14	–	–	ns
INPUTS: WS AND DATA						
t_{ST}	set-up time		8	–	–	ns
t_{HT}	hold time		0	–	–	ns
Q-to-W subcode timing; see Figs 7 and 8; note 1						
INPUT: SFSY						
t_{FW}	sync pulse width		244	272	800	μ s
t_F	frame cycle		122	136	150	μ s
t_{LW}	LOW level period		1.5	68	–	μ s
t_{HW}	HIGH level period		4	68	–	μ s
OUTPUT: \overline{RCK}						
t_{CD}	output delay time		5	20	30	μ s
t_{HPW}	HIGH level period		0.6	4	6	μ s
t_{LPW}	LOW level period		2	4	9	μ s
INPUT: SUB						
t_{HD}	data hold time		0	–	–	μ s
t_{AC}	data access time		–	–	0.8	μ s
t_{PAC}	P data access time		–	2	4	μ s
SRAM interface timing; see Figs 9 and 10; note 2						
t_{RC}	read cycle period		6T	–	–	ns
t_{DS}	data set-up time		30	–	–	ns
t_{DH}	data hold time		5	–	–	ns
t_{WC}	write cycle time		6T	–	–	ns
t_{WP}	write pulse time		2T	–	–	ns
t_{AS}	address set-up time		T	–	–	ns
t_{WR}	write recovery time		T	–	–	ns
t_{DO}	data output time		–	–	30	ns

Error correction and host interface IC for CD-ROM (ELM)

SAA7388

SYMBOL	PARAMETER	CONDITIONS	MIN.	TYP.	MAX.	UNIT
DRAM interface timing; see Figs 11 and 12; note 2						
t _{RC}	read or write cycle period		10T	–	–	ns
t _{PC}	page mode cycle time		4T	–	–	ns
t _{CAC}	access time from CAS		–	–	3T – 10	ns
t _{RAC}	access time from RAS		–	–	7T – 10	ns
t _{OFF}	output disable time from CAS		0	–	–	ns
t _{RHCP}	RAS hold time from CAS precharge page mode		4T	–	–	ns
t _{CAA}	column address access		–	–	4T	ns
t _{RP}	RAS HIGH time		4T	–	–	ns
t _{RAS}	RAS LOW time		6T	–	–	ns
t _{RSH}	RAS hold time		4T – 10	–	–	ns
t _{CAS}	CAS LOW time		3T	–	–	ns
t _{CSH}	CAS hold time		7T – 10	–	–	ns
t _{CP}	CAS HIGH pulse width		T	–	–	ns
t _{CRP}	delay CAS HIGH to RAS		3T – 10	–	–	ns
t _{RCD}	RAS to CAS delay time		2T	–	–	ns
t _{RAD}	RAS to column address delay		T	–	–	ns
t _{ASR}	row address set-up time		3T – 10	–	–	ns
t _{RAH}	row address hold time		T	–	–	ns
t _{ASC}	column address set-up time		T	–	–	ns
t _{CAH}	column address hold time		3T – 10	–	–	ns
t _{AR}	column address hold time from RAS LOW		5T – 10	–	–	ns
t _{RAL}	column address to RAS lead		3T	–	–	ns
t _{RCS}	read set-up time before CAS		4T – 10	–	–	ns
t _{RCH}	read command hold time		T	–	–	ns
t _{RRH}	read command hold time from RAS		2T – 10	–	–	ns
t _{WCH}	write command hold time		6T – 10	–	–	ns
t _{WP}	write command LOW time		10T	–	–	ns
t _{WCR}	write command hold time from RAS		8T – 10	–	–	ns
t _{CWL}	write command to CAS lead		9T – 10	–	–	ns
t _{RWL}	write command to RAS lead		8T – 10	–	–	ns
t _{DS}	data output set-up time		T	–	–	ns
t _{DH}	data output hold time		3T	–	–	ns
t _{DHR}	data output hold from RAS		7T – 10	–	–	ns
t _{RFSH}	refresh cycle time	MEMS(3) = 0	–	–	400T	ns
		MEMS(3) = 1	–	–	800T	ns
t _{CSR}	CAS set-up time for refresh		2T – 10	–	–	ns
t _{CHR}	CAS hold time for refresh		6T – 10	–	–	ns
t _{RPC}	precharge to CAS active time		T	–	–	ns

Error correction and host interface IC for CD-ROM (ELM)

SAA7388

SYMBOL	PARAMETER	CONDITIONS	MIN.	TYP.	MAX.	UNIT
Sub-CPU timing; see Fig.13						
t ₀	syn to first SCL		250	–	–	ns
t ₁	SCL cycle time		500	–	–	ns
t ₂	time between bytes		250	–	–	ns
t ₃	data set-up		150	–	–	ns
t ₄	data hold		0	–	–	ns
t ₅	data access		–	–	150	ns
ATAPI host interface timing; see Fig.14						
PIO 8 AND 16-BIT TRANSFER						
t ₀	cycle time	33 MHz clock	150	–	–	ns
		16 MHz clock	240	–	–	ns
t ₁	address to $\overline{\text{HWR}}/\overline{\text{HRD}}$ set-up		30	–	–	ns
t ₂	$\overline{\text{HWR}}/\overline{\text{HRD}}$ active	33 MHz clock	80	–	–	ns
		16 MHz clock	100	–	–	ns
t _{2i}	$\overline{\text{HWR}}/\overline{\text{HRD}}$ inactive	33 MHz clock	70	–	–	ns
		16 MHz clock	140	–	–	ns
t ₃	$\overline{\text{HWR}}$ data set-up		30	–	–	ns
t ₄	$\overline{\text{HWR}}$ data hold		10	–	–	ns
t ₅	$\overline{\text{HRD}}$ data set-up		50	–	–	ns
t ₆	$\overline{\text{HRD}}$ data 3-state		–	–	30	ns
t ₇	address to IOCS16	only for 16-bit data register	–	–	30	ns
t ₈	address to IOCS16 negate	only for 16-bit data register	–	–	30	ns
t ₉	$\overline{\text{HWR}}/\overline{\text{HRD}}$ to address hold		10	–	–	ns
t ₁₀	$\overline{\text{IORDY}}$ set-up		–	–	35	ns
t ₁₁	$\overline{\text{IORDY}}$ width	only if $\overline{\text{IORDY}}$ negated	–	–	1250	ns
t ₁₂	read data valid to $\overline{\text{IORDY}}$ active	only if $\overline{\text{IORDY}}$ negated	0	–	–	ns
SINGLE-WORD DMA TRANSFER; see Fig.15						
t ₀	cycle time	33 MHz clock	240	–	–	ns
		16 MHz clock	480	–	–	ns
t ₁	DMACK to $\overline{\text{DMARQ}}$		–	–	80	ns
t ₂	DMACK to $\overline{\text{HWR}}/\overline{\text{HRD}}$		0	–	–	ns
t ₃	$\overline{\text{HWR}}/\overline{\text{HRD}}$ active	33 MHz clock	120	–	–	ns
		16 MHz clock	240	–	–	ns
t ₄	$\overline{\text{HWR}}/\overline{\text{HRD}}$ to DMACK hold		0	–	–	ns
t ₅	$\overline{\text{HWR}}$ data set-up		35	–	–	ns
t ₆	$\overline{\text{HWR}}$ data hold		20	–	–	ns
t ₇	$\overline{\text{HRD}}$ data access		–	–	60	ns
t ₈	$\overline{\text{HRD}}$ data hold		5	–	–	ns

Error correction and host interface IC for CD-ROM (ELM)

SAA7388

SYMBOL	PARAMETER	CONDITIONS	MIN.	TYP.	MAX.	UNIT
MULTI-WORD DMA TRANSFER; see Fig.16; note 3						
t ₀	cycle time		130	–	–	ns
t ₁	$\overline{\text{HWR}}/\overline{\text{HRD}}$ to $\overline{\text{DMARQ}}$ inactive		–	–	40	ns
t ₂	$\overline{\text{DMACK}}$ to $\overline{\text{HWR}}/\overline{\text{HRD}}$		0	–	–	ns
t ₃	$\overline{\text{HWR}}/\overline{\text{HRD}}$ active		80	–	–	ns
t ₄	$\overline{\text{HWR}}/\overline{\text{HRD}}$ inactive		50	–	–	ns
t ₅	$\overline{\text{HWR}}/\overline{\text{HRD}}$ to $\overline{\text{DMACK}}$ hold		5	–	–	ns
t ₆	$\overline{\text{HWR}}$ data set-up		30	–	–	ns
t ₇	$\overline{\text{HWR}}$ data hold		15	–	–	ns
t ₈	$\overline{\text{HRD}}$ data access		–	–	60	ns
t ₉	$\overline{\text{HRD}}$ data hold		5	–	–	ns
t ₁₀	$\overline{\text{DMACK}}$ inactive to read data 3-state		–	–	25	ns
Sanyo compatibility mode host interface timing; see Fig.17						
COMIN AND SBOU ACCESS						
t ₀	$\overline{\text{HEN}}$ set-up		30	–	–	ns
t ₁	$\overline{\text{HEN}}$ hold		0	–	–	ns
t ₂	$\overline{\text{CMD}}$ set-up		15	–	–	ns
t ₃	$\overline{\text{CMD}}$ hold		5	–	–	ns
t ₄	$\overline{\text{HWR}}/\overline{\text{HRD}}$ active	33 MHz clock	50	–	–	ns
		16 MHz clock	75	–	–	ns
t ₅	$\overline{\text{HWR}}/\overline{\text{HRD}}$ data inactive	33 MHz clock	60	–	–	ns
		16 MHz clock	145	–	–	ns
t ₆	$\overline{\text{HWR}}$ data set-up		50	–	–	ns
t ₇	$\overline{\text{HWR}}$ data hold		20	–	–	ns
t ₈	$\overline{\text{HRD}}$ data access		–	–	80	ns
t ₉	$\overline{\text{HRD}}$ data to 3-state		5	–	60	ns
t ₁₀	$\overline{\text{STEN}}$ to $\overline{\text{HRD}}$	only for SBOU read	0	–	–	ns
t ₁₁	$\overline{\text{HRD}}$ to $\overline{\text{STEN}}$ inactive	for last SBOU read; 33 MHz clock	–	–	100	ns
		16 MHz clock	–	–	145	ns
t ₁₂	$\overline{\text{HWR}}$ to $\overline{\text{DTEN}}/\overline{\text{STEN}}$ inactive	only for COMIN write when CMDBK = 0	–	–	100	ns

Error correction and host interface IC for CD-ROM (ELM)

SAA7388

SYMBOL	PARAMETER	CONDITIONS	MIN.	TYP.	MAX.	UNIT
WAIT CONTROL DATA TRANSFER; see Fig.18						
t ₀	$\overline{H\overline{EN}}$ set-up		30	–	–	ns
t ₁	$\overline{H\overline{EN}}$ hold		0	–	–	ns
t ₂	CMD set-up		15	–	–	ns
t ₃	CMD hold		5	–	–	ns
t ₄	$\overline{H\overline{WR}}/\overline{H\overline{RD}}$ active	33 MHz clock	50	–	–	ns
		16 MHz clock	75	–	–	ns
t ₅	$\overline{H\overline{WR}}/\overline{H\overline{RD}}$ inactive	33 MHz clock	60	–	–	ns
		16 MHz clock	145	–	–	ns
t ₆	$\overline{H\overline{WR}}$ data set-up		50	–	–	ns
t ₇	$\overline{H\overline{WR}}$ data hold		20	–	–	ns
t ₈	$\overline{H\overline{RD}}$ data access		–	–	80	ns
t ₉	$\overline{H\overline{RD}}$ data to 3-state		5	–	60	ns
t ₁₀	$\overline{H\overline{WR}}/\overline{H\overline{RD}}$ to $\overline{W\overline{AIT}}$ active		–	–	80	ns
t ₁₁	$\overline{D\overline{TEN}}$ to $\overline{H\overline{WR}}/\overline{H\overline{RD}}$		0	–	–	ns
t ₁₂	$\overline{H\overline{WR}}/\overline{H\overline{RD}}$ to $\overline{D\overline{TEN}}$ inactive	for last data transferred; 33 MHz clock	–	–	100	ns
		16 MHz clock	–	–	145	ns
t ₁₃	$\overline{H\overline{WR}}/\overline{H\overline{RD}}$ to $\overline{E\overline{OP}}$	only for last data access	–	–	120	ns
t ₁₄	$\overline{H\overline{WR}}/\overline{H\overline{RD}}$ inactive to $\overline{E\overline{OP}}$ inactive	only for last data access	–	–	120	ns
DRQ CONTROL DATA TRANSFER; see Fig.19						
t ₀	$\overline{H\overline{EN}}$ set-up		30	–	–	ns
t ₁	$\overline{H\overline{EN}}$ hold		0	–	–	ns
t ₂	CMD set-up		15	–	–	ns
t ₃	CMD hold		5	–	–	ns
t ₄	$\overline{H\overline{WR}}/\overline{H\overline{RD}}$ active	33 MHz clock	50	–	–	ns
		16 MHz clock	75	–	–	ns
t ₅	$\overline{H\overline{WR}}/\overline{H\overline{RD}}$ data inactive	33 MHz clock	60	–	–	ns
		16 MHz clock	145	–	–	ns
t ₆	$\overline{H\overline{WR}}$ data set-up		50	–	–	ns
t ₇	$\overline{H\overline{WR}}$ data hold		20	–	–	ns
t ₈	$\overline{H\overline{RD}}$ data access		–	–	80	ns
t ₉	$\overline{H\overline{RD}}$ data to 3-state		5	–	60	ns
t ₁₀	DRQ to $\overline{H\overline{WR}}/\overline{H\overline{RD}}$		0	–	–	ns
t ₁₁	$\overline{H\overline{WR}}/\overline{H\overline{RD}}$ to DRQ inactive		–	–	80	ns
t ₁₂	$\overline{D\overline{TEN}}$ to $\overline{H\overline{WR}}/\overline{H\overline{RD}}$		0	–	–	ns
t ₁₃	$\overline{H\overline{WR}}/\overline{H\overline{RD}}$ to $\overline{D\overline{TEN}}$ inactive	for last data transferred; 33 MHz clock	–	–	100	ns
		16 MHz clock	–	–	145	ns
t ₁₄	$\overline{H\overline{WR}}/\overline{H\overline{RD}}$ to $\overline{E\overline{OP}}$	only for last data access	–	–	120	ns

Error correction and host interface IC for CD-ROM (ELM)

SAA7388

SYMBOL	PARAMETER	CONDITIONS	MIN.	TYP.	MAX.	UNIT
t ₁₅	$\overline{\text{HWR/HRD}}$ inactive to $\overline{\text{EOP}}$ inactive	only for last data access	–	–	120	ns
Oak compatibility mode host interface timing; see Fig.20						
COMIN, HCON WRITE AND SBOUT, TSTAT READ						
t ₀	$\overline{\text{HEN}}$ set-up		30	–	–	ns
t ₁	$\overline{\text{HEN}}$ hold		0	–	–	ns
t ₂	DMACK set-up		30	–	–	ns
t ₃	DMACK hold		0	–	–	ns
t ₄	address set-up		30	–	–	ns
t ₅	address hold		0	–	–	ns
t ₆	$\overline{\text{HWR/HRD}}$ active	33 MHz clock	50	–	–	ns
		16 MHz clock	75	–	–	ns
t ₇	$\overline{\text{HWR/HRD}}$ inactive	33 MHz clock	60	–	–	ns
		16 MHz clock	145	–	–	ns
t ₈	$\overline{\text{HWR}}$ data set-up		50	–	–	ns
t ₉	$\overline{\text{HWR}}$ data hold		20	–	–	ns
t ₁₀	$\overline{\text{HRD}}$ data access		–	–	80	ns
t ₁₁	$\overline{\text{HRD}}$ data to 3-state		5	–	60	ns
$\overline{\text{RESET}}$ SUB-CPU; see Fig.21; note 4						
t ₀	$\overline{\text{HEN}}$ set-up		30	–	–	ns
t ₁	$\overline{\text{HEN}}$ hold		0	–	–	ns
t ₂	DMACK set-up		30	–	–	ns
t ₃	DMACK hold		0	–	–	ns
t ₄	address set-up		30	–	–	ns
t ₅	address hold		0	–	–	ns
t ₆	$\overline{\text{HWR}}$ active	33 MHz clock	50	–	–	ns
		16 MHz clock	65	–	–	ns
t ₇	$\overline{\text{HWR}}$ inactive	33 MHz clock	60	–	–	ns
		16 MHz clock	145	–	–	ns
t ₈	$\overline{\text{HWR}}$ to $\overline{\text{SCRST}}$		–	–	100	ns
t ₉	$\overline{\text{HWR}}$ inactive to $\overline{\text{SCRST}}$ inactive		512CLK	–	–	ns
NON-DMA DATA TRANSFER; see Fig.22; note 4						
t ₀	$\overline{\text{HEN}}$ set-up		30	–	–	ns
t ₁	$\overline{\text{HEN}}$ hold		0	–	–	ns
t ₂	DMACK set-up		30	–	–	ns
t ₃	DMACK hold		0	–	–	ns
t ₄	address set-up		30	–	–	ns
t ₅	address hold		0	–	–	ns
t ₆	$\overline{\text{HWR/HRD}}$ active	33 MHz clock	50	–	–	ns
		16 MHz clock	75	–	–	ns

Error correction and host interface IC for CD-ROM (ELM)

SAA7388

SYMBOL	PARAMETER	CONDITIONS	MIN.	TYP.	MAX.	UNIT
t ₇	$\overline{\text{HWR}}/\overline{\text{HRD}}$ inactive	33 MHz clock	60	–	–	ns
		16 MHz clock	145	–	–	ns
t ₈	$\overline{\text{HWR}}$ data set-up		50	–	–	ns
t ₉	$\overline{\text{HWR}}$ data hold		20	–	–	ns
t ₁₀	$\overline{\text{HRD}}$ data access		–	–	80	ns
t ₁₁	$\overline{\text{HRD}}$ data to 3-state		5	–	60	ns
t ₁₂	cycle time		3CLK	–	–	ns
8-BIT DMA DATA TRANSFER; see Fig.23						
t ₀	$\overline{\text{DMARQ}}$ to $\overline{\text{DMACK}}$		0	–	–	ns
t ₁	$\overline{\text{HWR}}/\overline{\text{HRD}}$ to $\overline{\text{DMARQ}}$ inactive		–	–	80	ns
t ₂	$\overline{\text{DMACK}}$ set-up		30	–	–	ns
t ₃	$\overline{\text{DMACK}}$ hold		0	–	–	ns
t ₄	$\overline{\text{HWR}}/\overline{\text{HRD}}$ active	33 MHz clock	50	–	–	ns
		16 MHz clock	75	–	–	ns
t ₅	$\overline{\text{HWR}}/\overline{\text{HRD}}$ inactive	33 MHz clock	60	–	–	ns
		16 MHz clock	145	–	–	ns
t ₆	$\overline{\text{HWR}}$ data set-up		50	–	–	ns
t ₇	$\overline{\text{HWR}}$ data hold		20	–	–	ns
t ₈	$\overline{\text{HRD}}$ data access		–	–	80	ns
t ₉	$\overline{\text{HRD}}$ data to 3-state		–	–	60	ns
PSEUDO 16-BIT DMA READ TRANSFER; see Fig.24; note 4						
t ₀	$\overline{\text{HRD}}$ to $\overline{\text{DMARQ}}$ inactive		–	–	80	ns
t ₁	$\overline{\text{DMARQ}}$ to $\overline{\text{DMACK}}$		0	–	–	ns
t ₂	$\overline{\text{HRD}}$ inactive to $\overline{\text{DMACK}}$ inactive		0	–	–	ns
t ₃	$\overline{\text{HRD}}$ active	33 MHz clock	50	–	–	ns
		16 MHz clock	65	–	–	ns
t ₄	$\overline{\text{HFBC}}$ to data valid		–	–	CLK	ns
t ₅	data 3-state to $\overline{\text{HFBC}}$ inactive		CLK	–	–	ns
t ₆	$\overline{\text{HRD}}$ data access		–	–	80	ns
t ₇	$\overline{\text{HRD}}$ data to 3-state		–	–	60	ns
t ₈	$\overline{\text{HFBC}}$ active		–	–	5CLK	ns
t ₉	data valid to $\overline{\text{HFBLB}}$		2CLK	–	–	ns
t ₁₀	$\overline{\text{HFBLB}}$ to $\overline{\text{HFBC}}$ inactive		2CLK	–	–	ns

Notes

1. All timings are for single-speed, they should be divided by the speed up to eight times speed.
2. T represents half a clock period.
3. The timings for this mode can only be met with a 33 MHz clock.
4. CLK = 1 clock period.

Error correction and host interface IC for
CD-ROM (ELM)

SAA7388

11.1 Q-to-W subcode interface timing

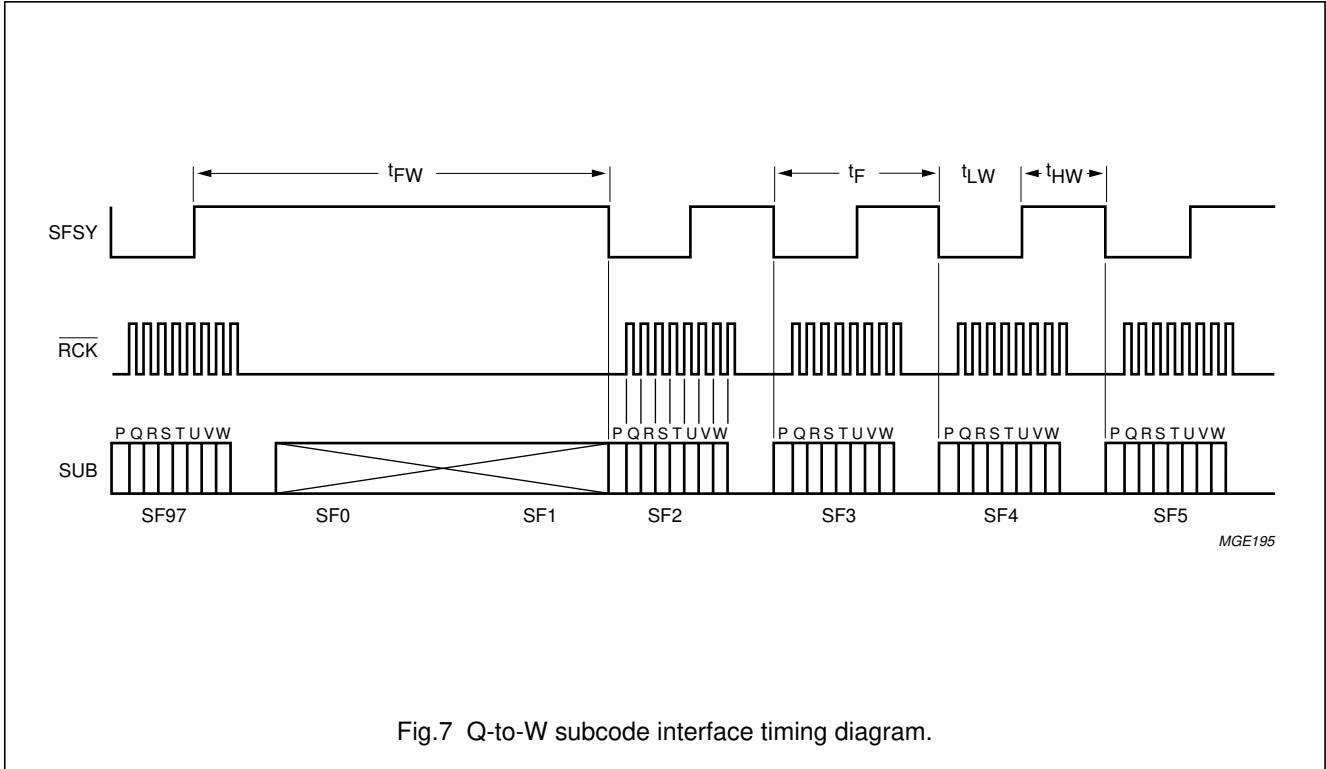

Fig.7 Q-to-W subcode interface timing diagram.

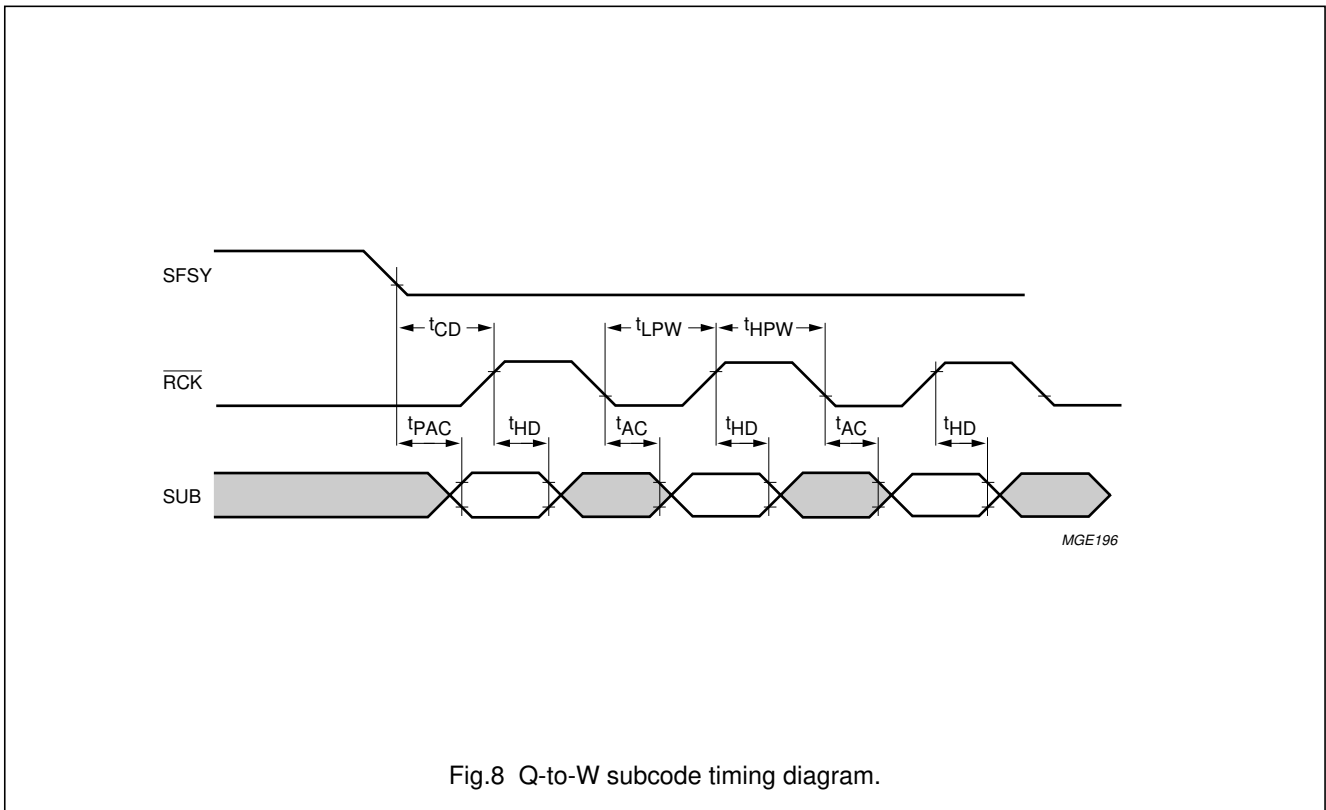

Fig.8 Q-to-W subcode timing diagram.

Error correction and host interface IC for CD-ROM (ELM)

SAA7388

11.2 External memory SRAM timing

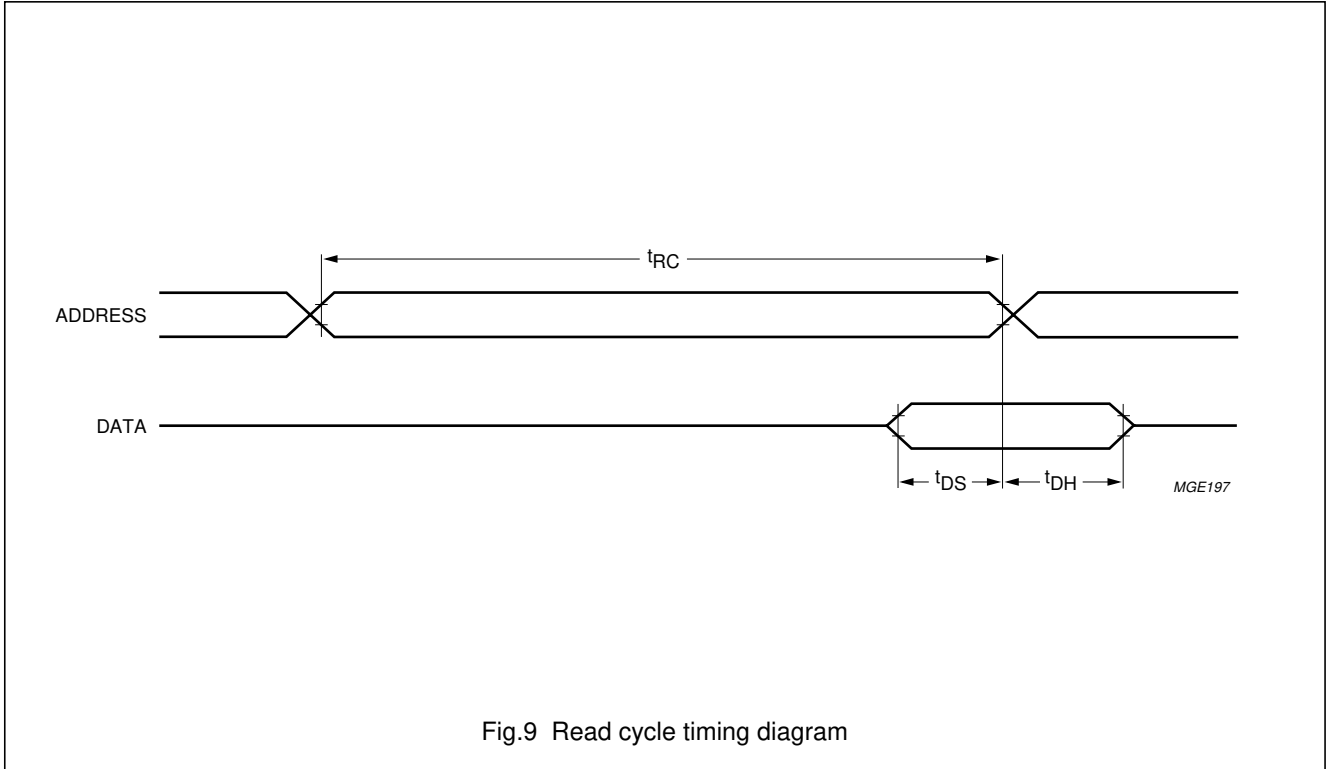

Fig.9 Read cycle timing diagram

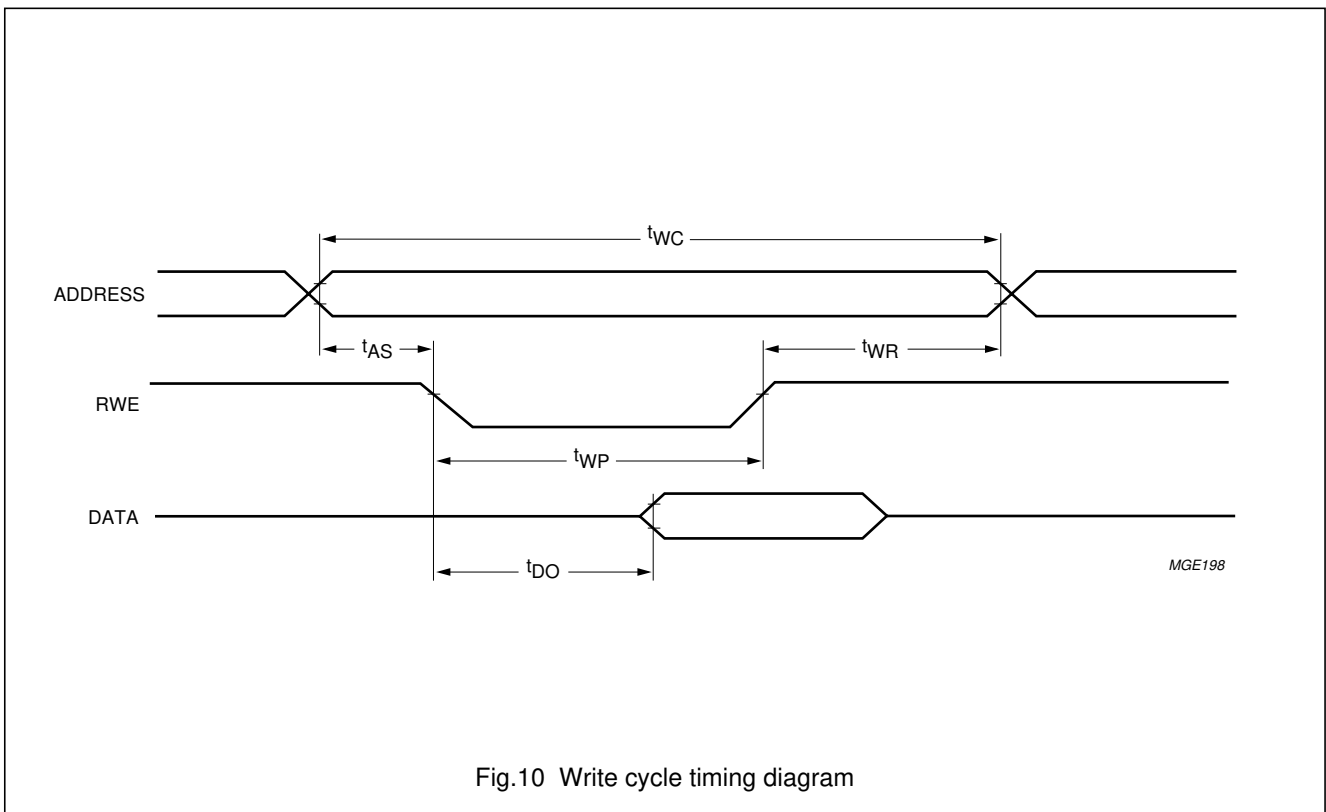

Fig.10 Write cycle timing diagram

Error correction and host interface IC for
CD-ROM (ELM)

SAA7388

11.3 External memory DRAM timing

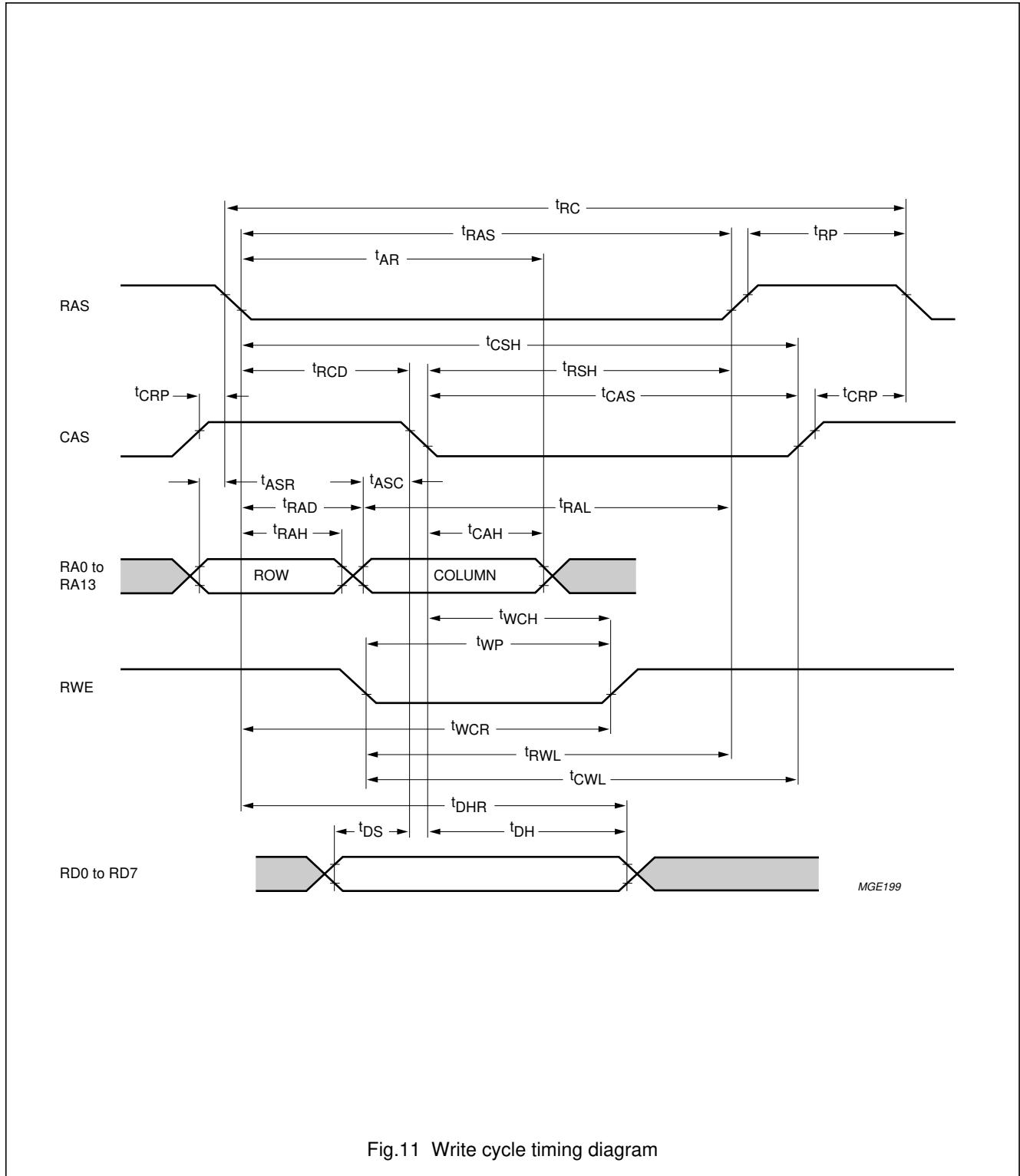

Fig.11 Write cycle timing diagram

Error correction and host interface IC for
CD-ROM (ELM)

SAA7388

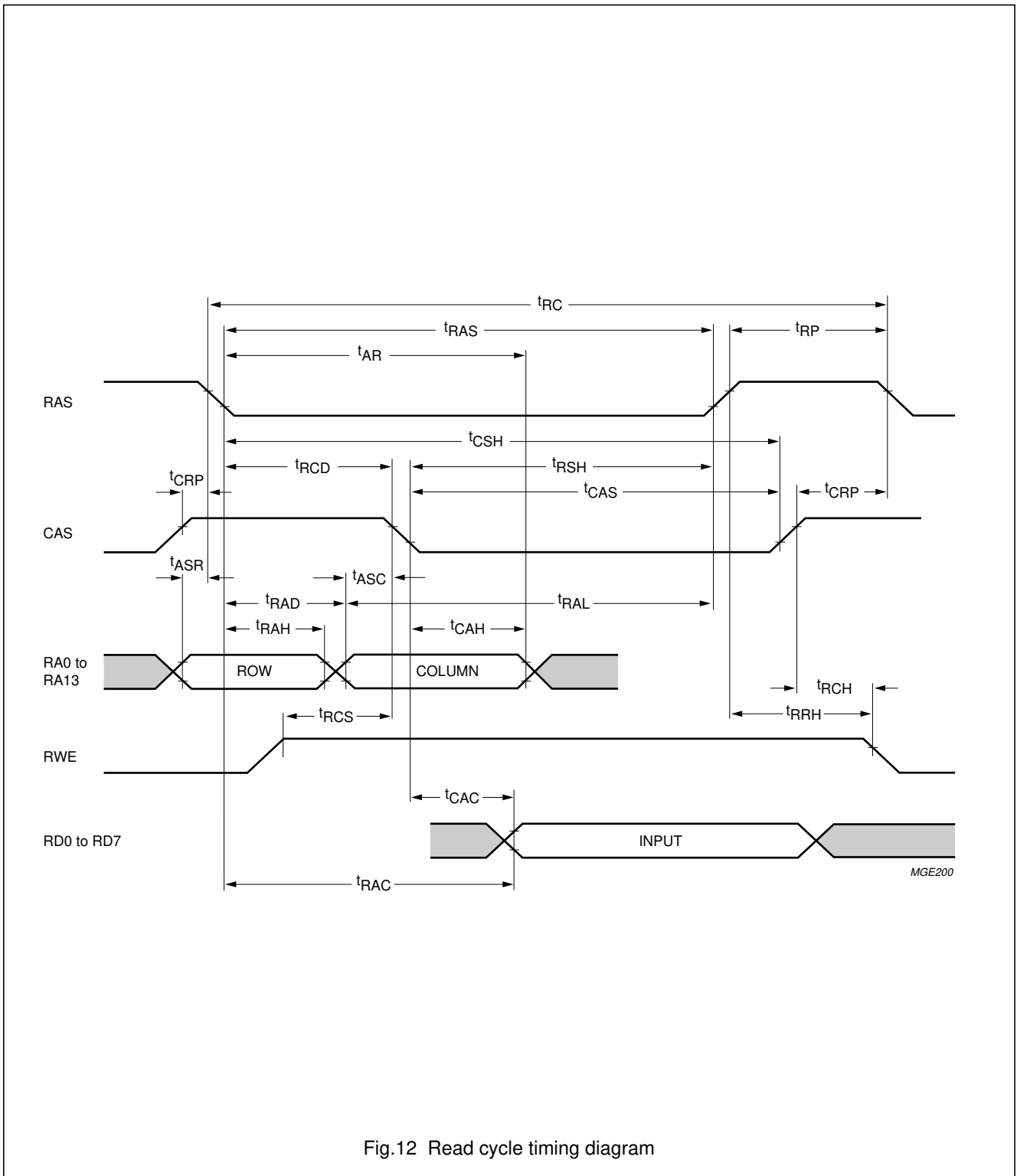

Fig.12 Read cycle timing diagram

Error correction and host interface IC for CD-ROM (ELM)

SAA7388

11.4 Sub-CPU interface timing

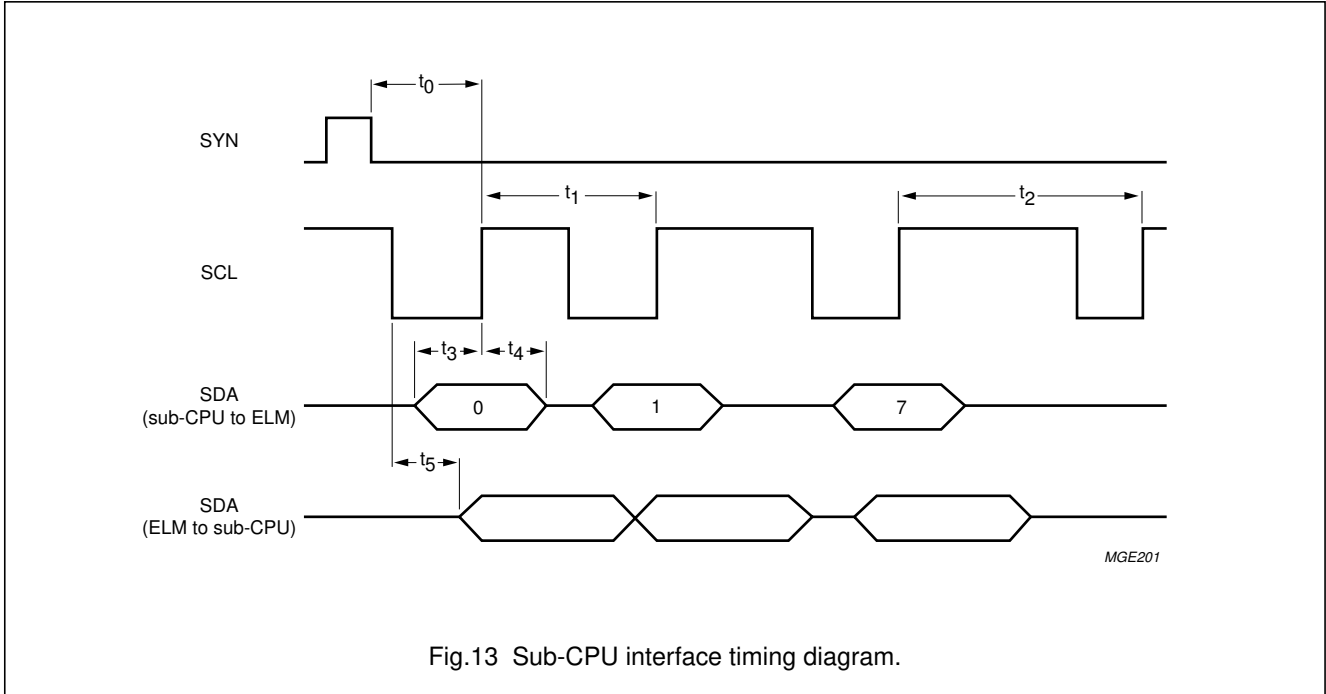

Fig.13 Sub-CPU interface timing diagram.

11.5 ATAPI host interface timing

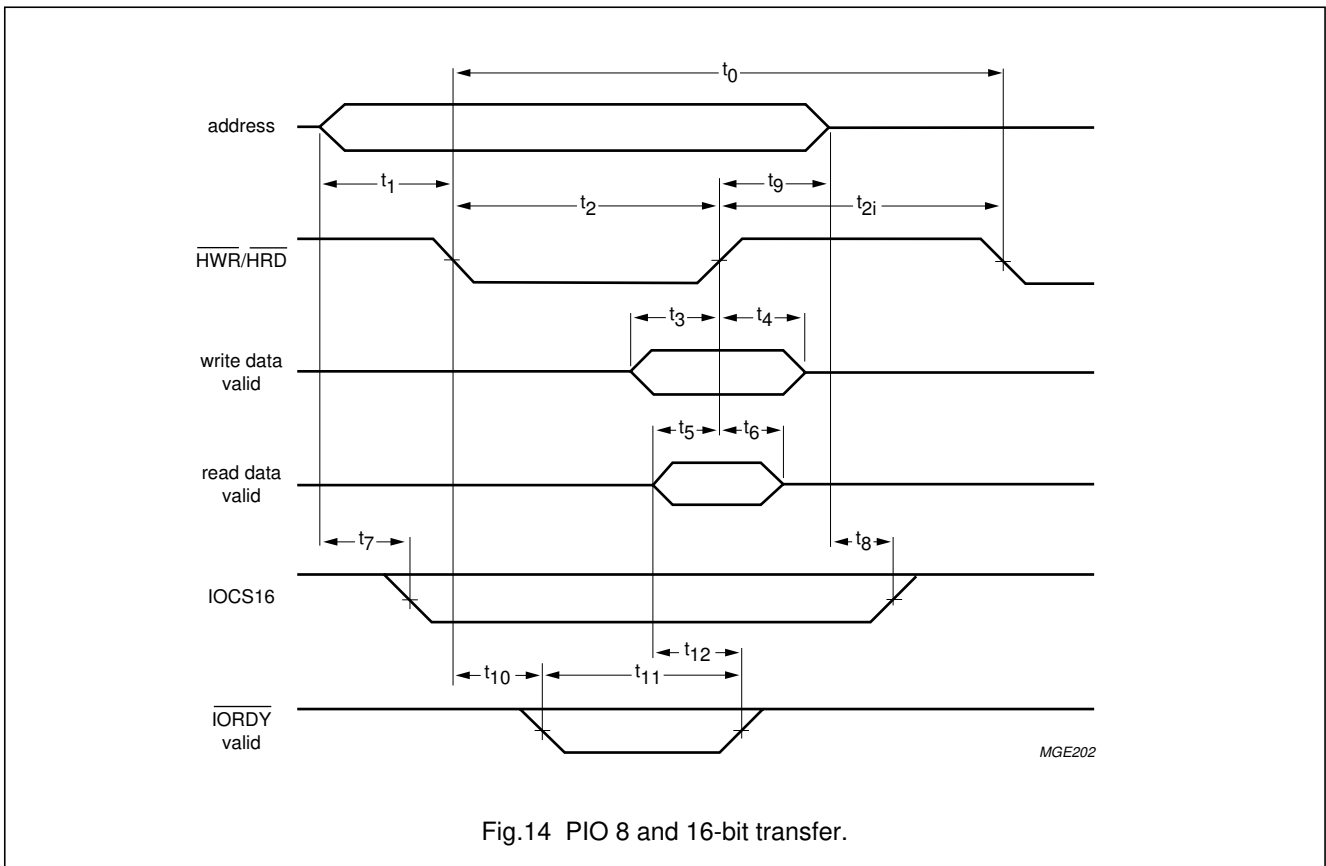

Fig.14 PIO 8 and 16-bit transfer.

Error correction and host interface IC for CD-ROM (ELM)

SAA7388

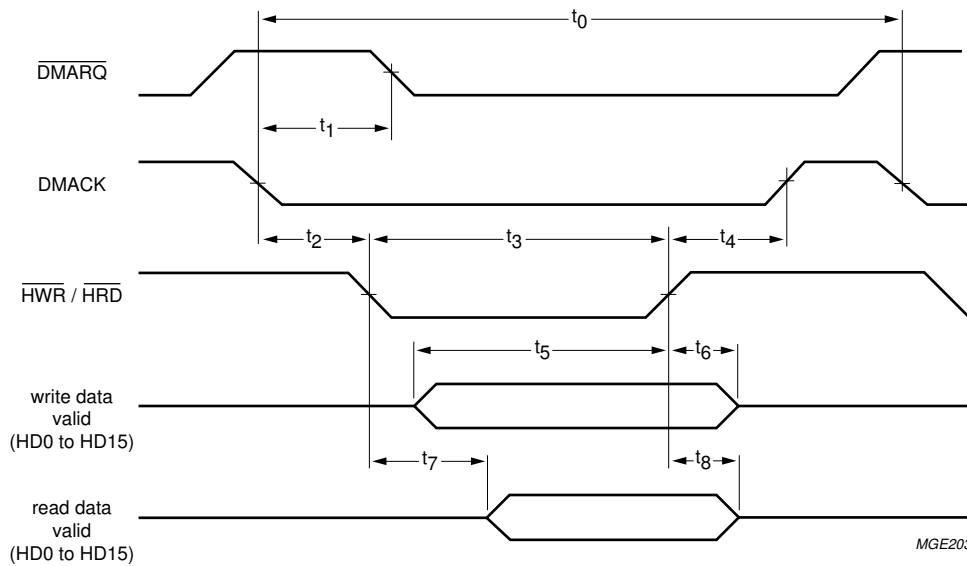

Fig.15 Single-word DMA transfer.

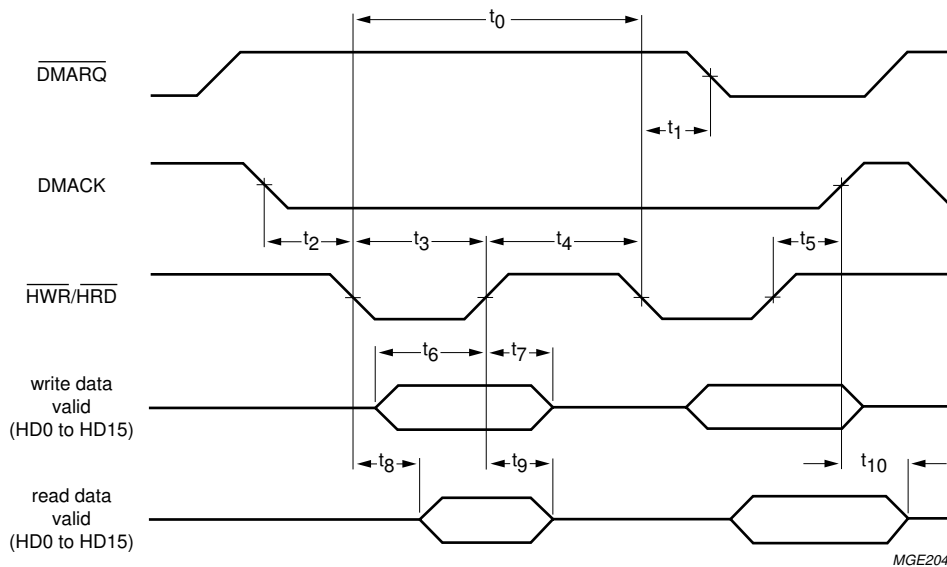

Fig.16 Multi-word DMA transfer.

Error correction and host interface IC for
CD-ROM (ELM)

SAA7388

11.6 SANYO compatibility mode host interface timing

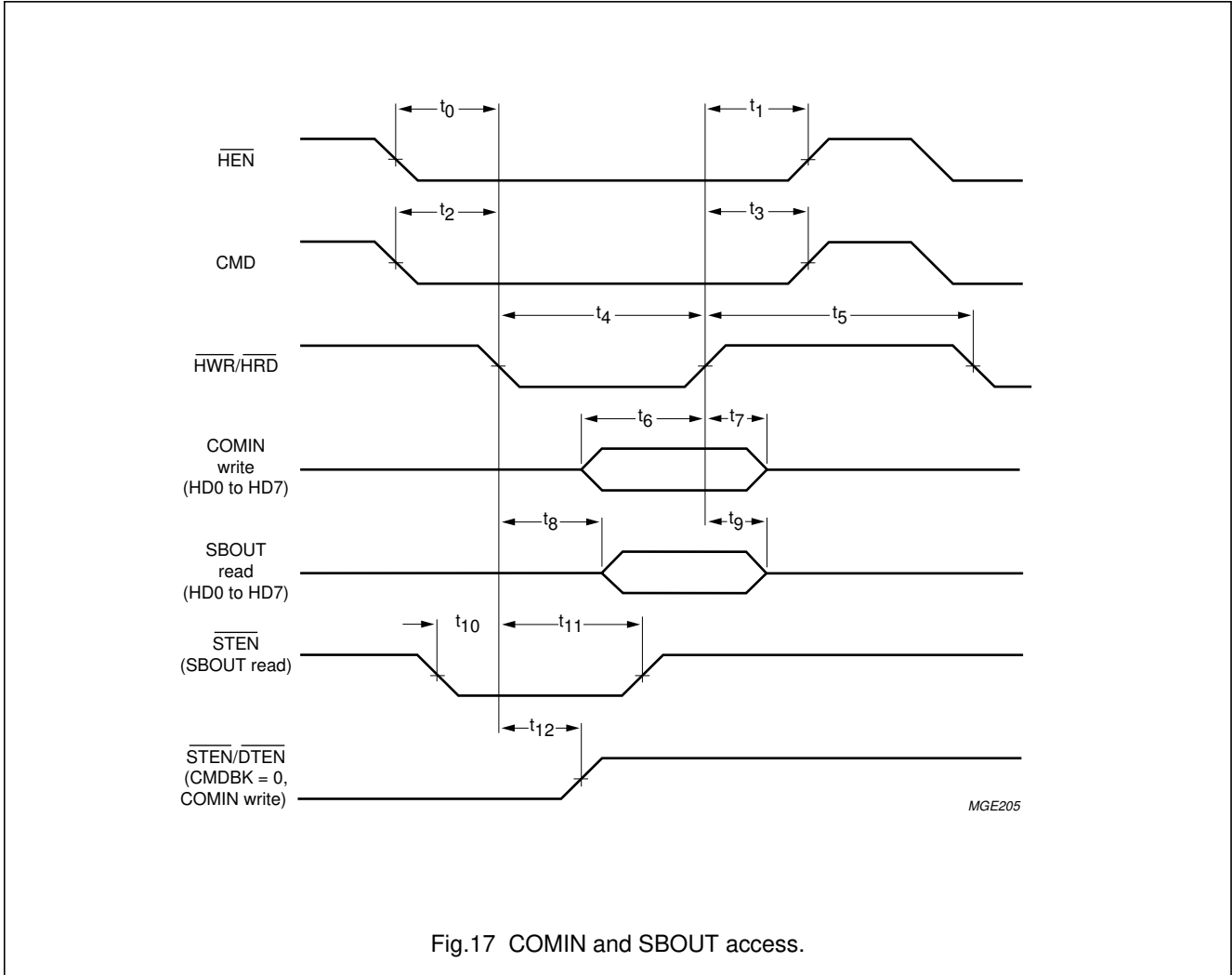

Fig.17 COMIN and SBOUT access.

Error correction and host interface IC for CD-ROM (ELM)

SAA7388

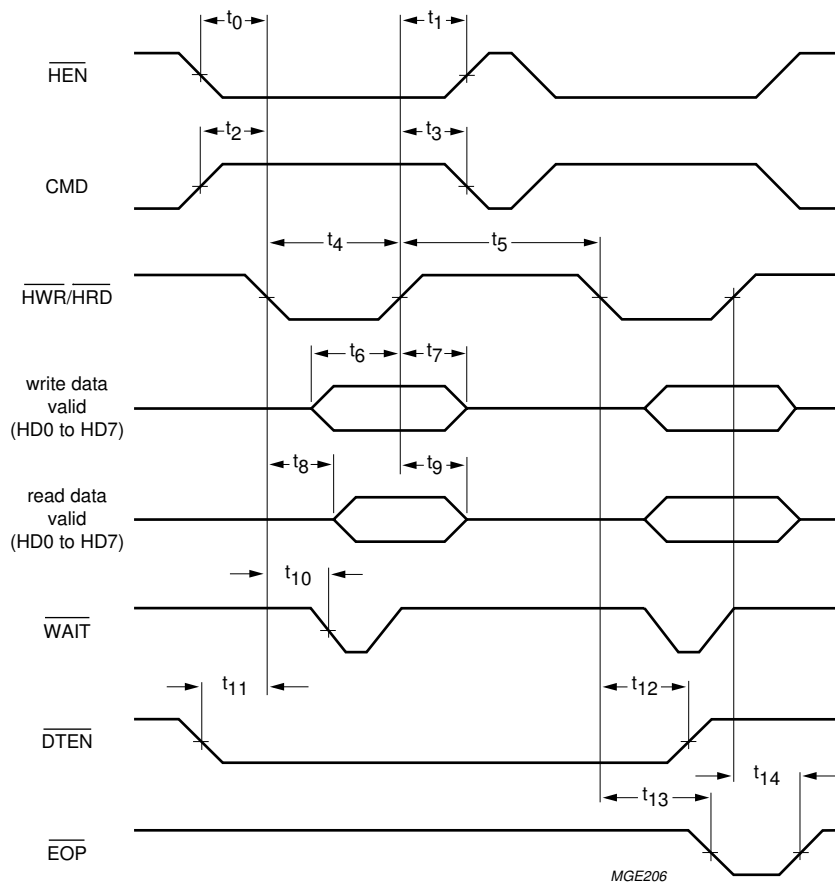

Fig.18 $\overline{\text{WAIT}}$ control and data transfer.

Error correction and host interface IC for CD-ROM (ELM)

SAA7388

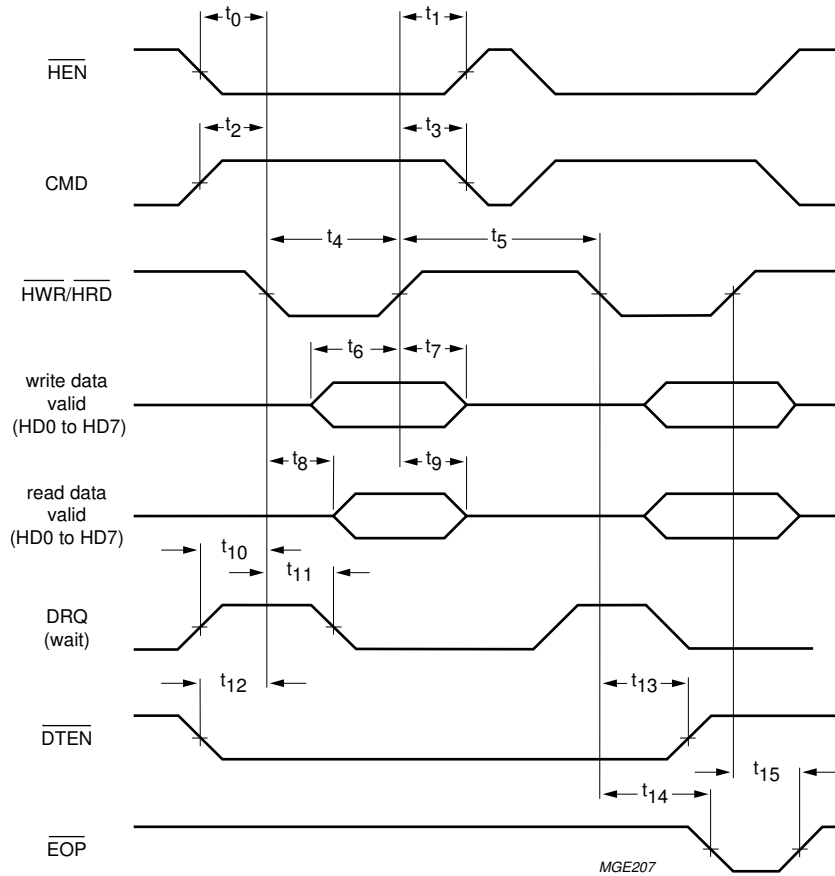
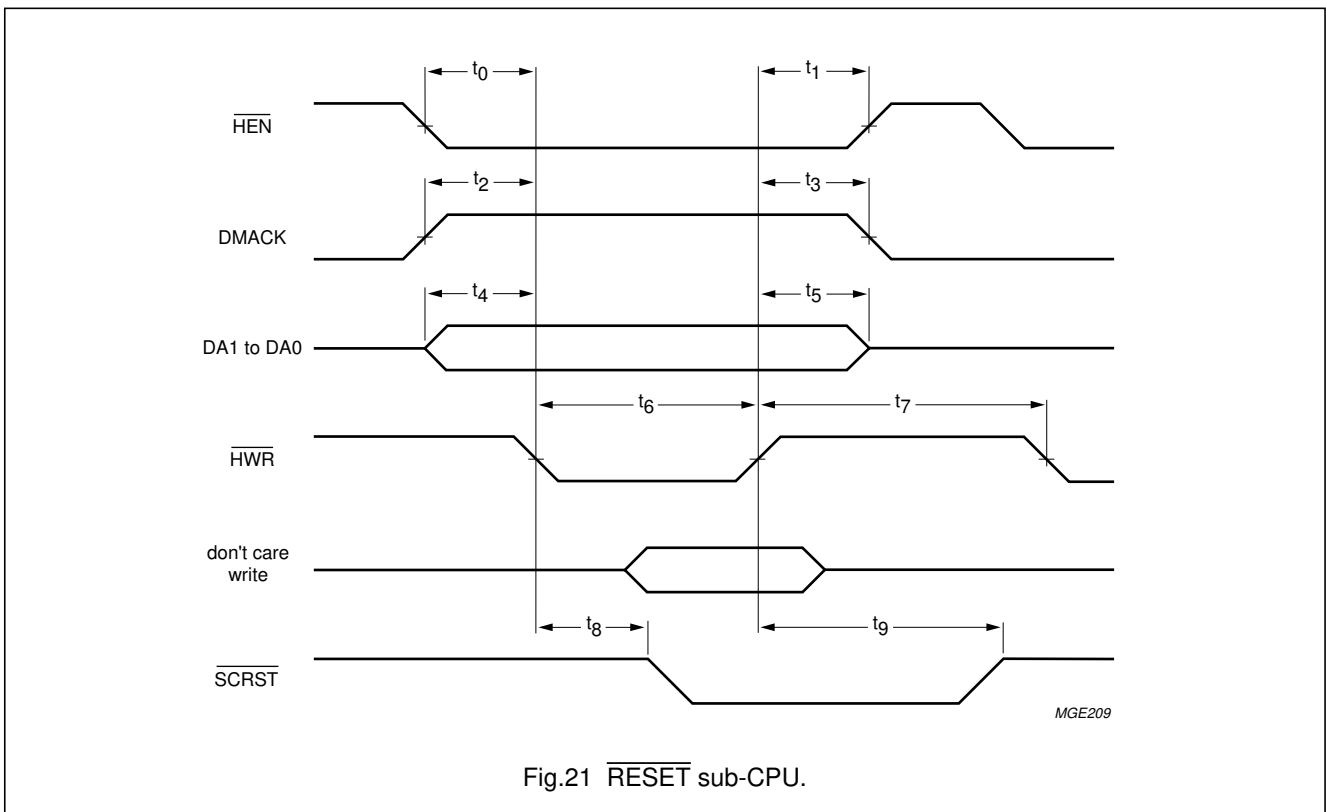
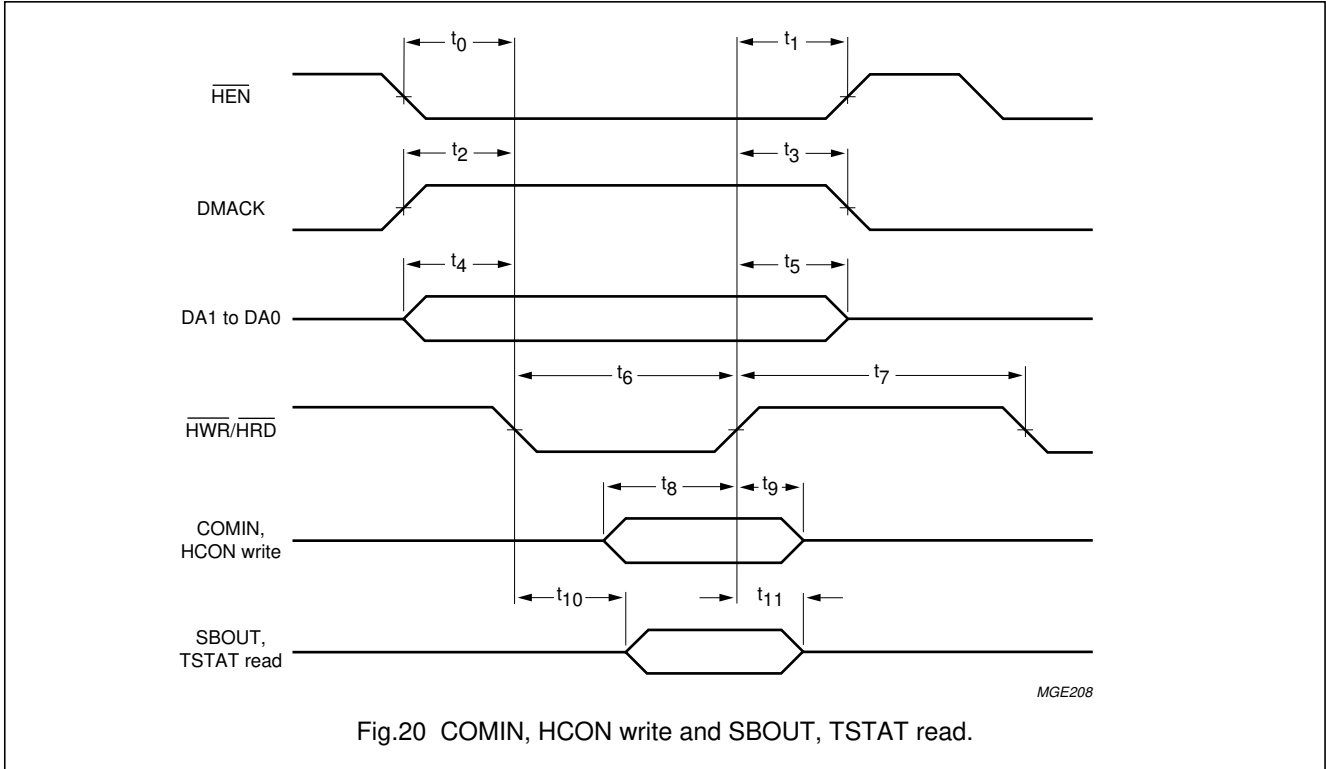

Fig.19 DRQ control data transfer.

Error correction and host interface IC for CD-ROM (ELM)

SAA7388

11.7 Oak compatibility mode host interface timing



Error correction and host interface IC for
CD-ROM (ELM)

SAA7388

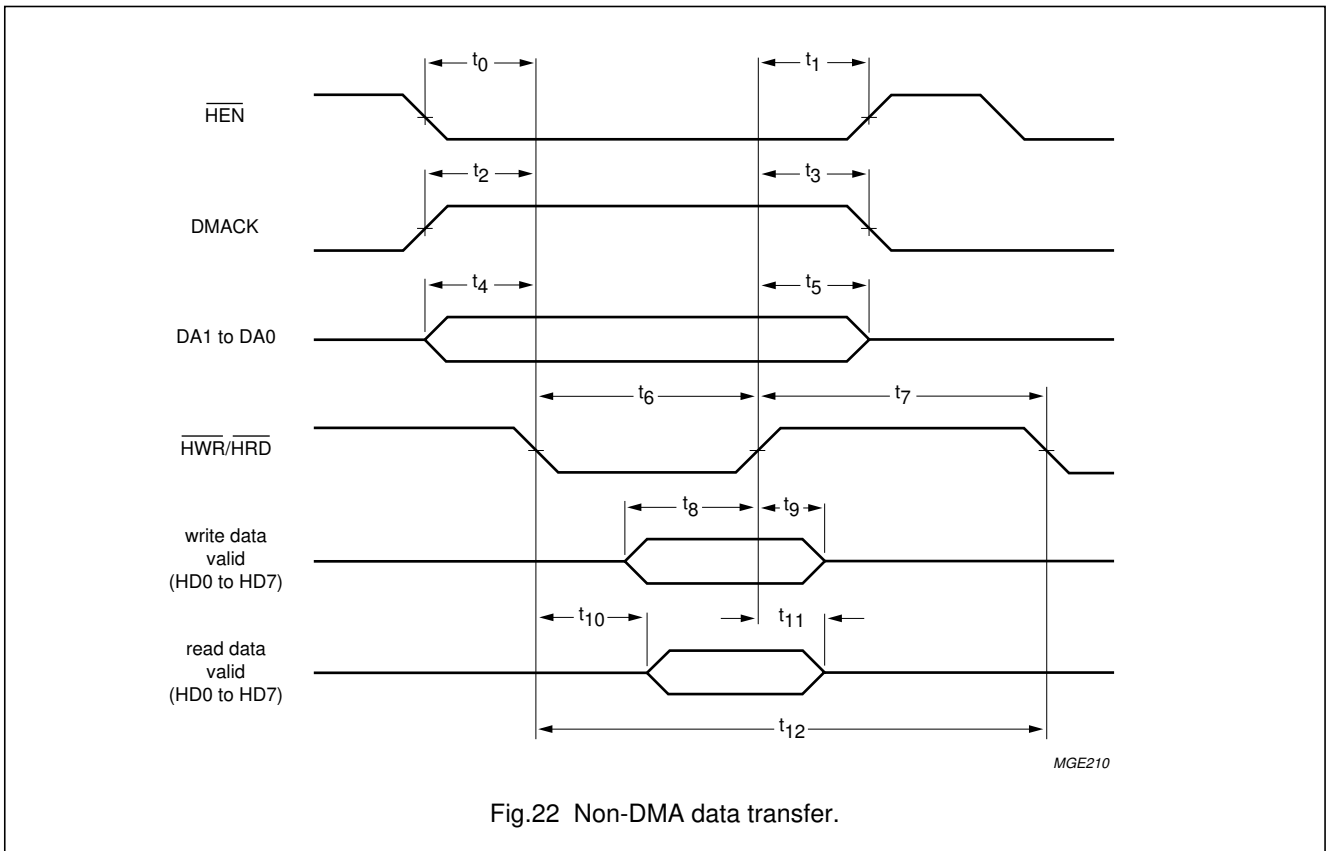

Fig.22 Non-DMA data transfer.

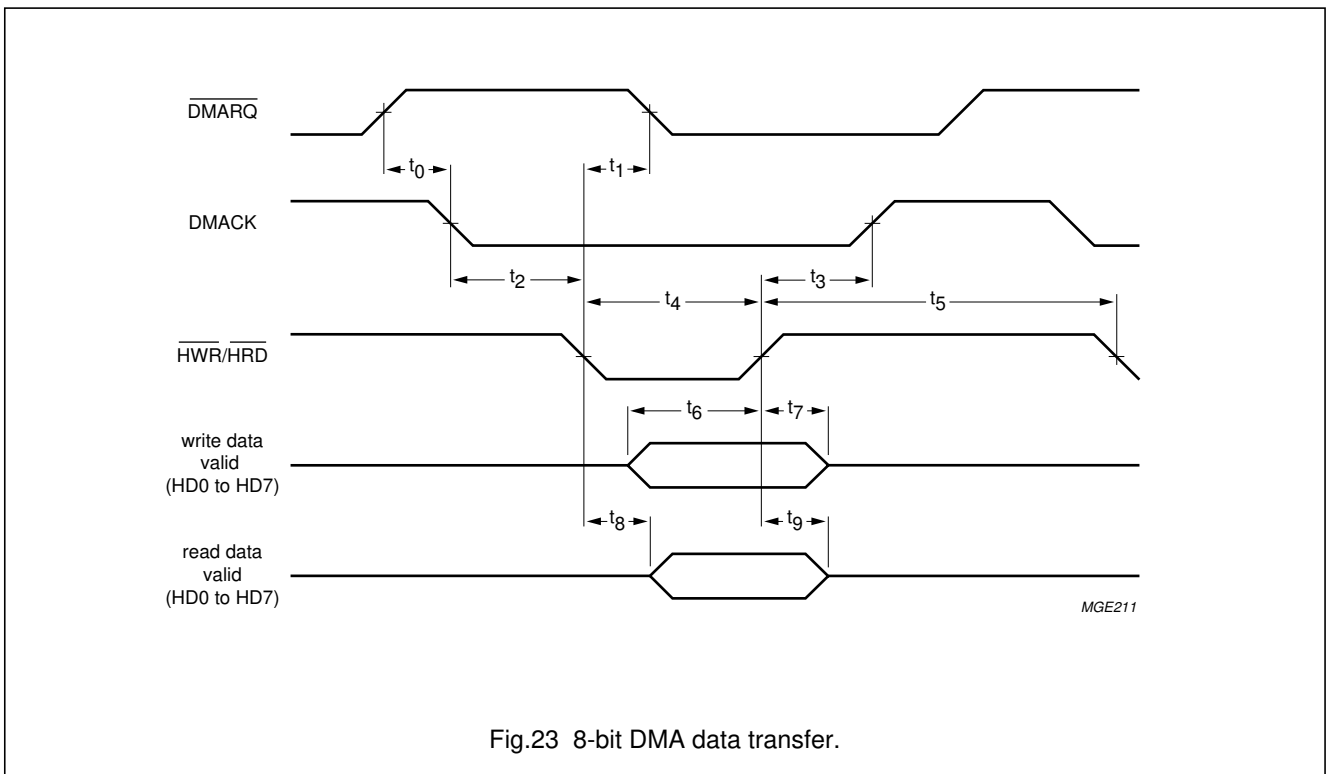

Fig.23 8-bit DMA data transfer.

Error correction and host interface IC for CD-ROM (ELM)

SAA7388

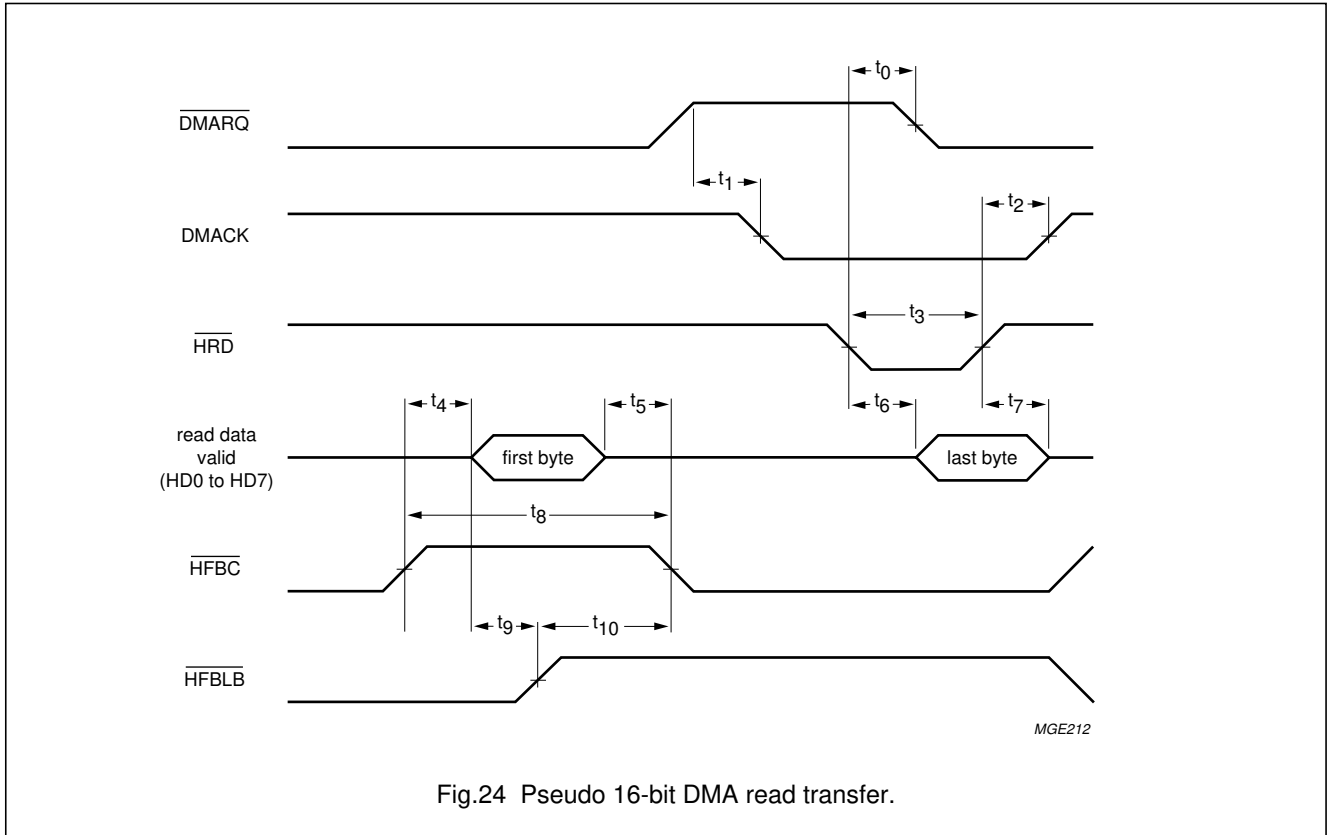

Fig.24 Pseudo 16-bit DMA read transfer.

11.8 Crystal oscillator

The crystal oscillator is a conventional 2 pin design operating at 15 to 50.4 MHz. This oscillator is also capable of operating with a ceramic resonator. It is capable of oscillating with both fundamental and third overtone mode crystals. External components should be used to suppress the fundamental output of the third overtone types as illustrated in Fig.25.

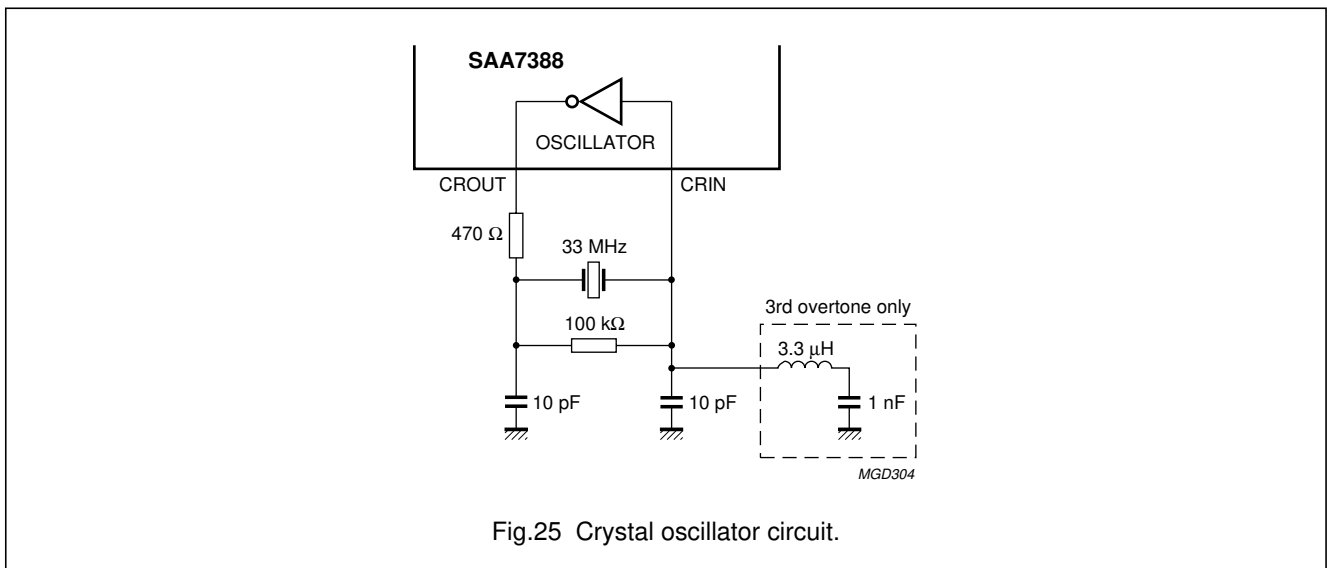

Fig.25 Crystal oscillator circuit.

Error correction and host interface IC for CD-ROM (ELM)

SAA7388

12 PACKAGE OUTLINE

QFP80: plastic quad flat package; 80 leads (lead length 1.95 mm); body 14 x 20 x 2.8 mm

SOT318-2

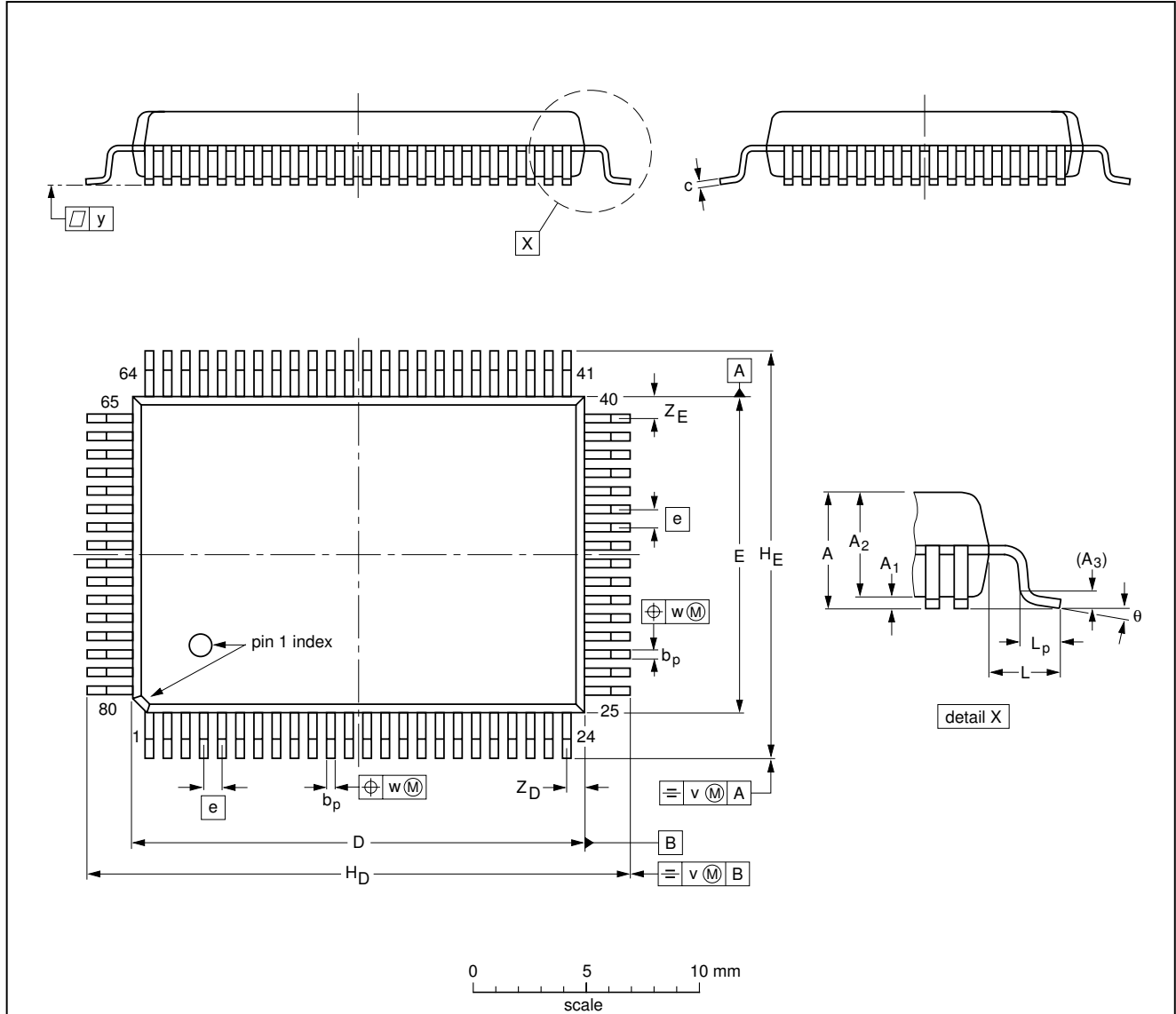

DIMENSIONS (mm are the original dimensions)

UNIT	A max.	A ₁	A ₂	A ₃	b _p	c	D ⁽¹⁾	E ⁽¹⁾	e	H _D	H _E	L	L _p	v	w	y	Z _D ⁽¹⁾	Z _E ⁽¹⁾	θ
mm	3.2	0.25 0.05	2.90 2.65	0.25	0.45 0.30	0.25 0.14	20.1 19.9	14.1 13.9	0.8	24.2 23.6	18.2 17.6	1.95	1.0 0.6	0.2	0.2	0.1	1.0 0.6	1.2 0.8	7° 0°

Note

1. Plastic or metal protrusions of 0.25 mm maximum per side are not included.

OUTLINE VERSION	REFERENCES				EUROPEAN PROJECTION	ISSUE DATE
	IEC	JEDEC	EIAJ			
SOT318-2						95-02-04 97-08-01

Error correction and host interface IC for CD-ROM (ELM)

SAA7388

13 SOLDERING

13.1 Introduction

There is no soldering method that is ideal for all IC packages. Wave soldering is often preferred when through-hole and surface mounted components are mixed on one printed-circuit board. However, wave soldering is not always suitable for surface mounted ICs, or for printed-circuits with high population densities. In these situations reflow soldering is often used.

This text gives a very brief insight to a complex technology. A more in-depth account of soldering ICs can be found in our "IC Package Databook" (order code 9398 652 90011).

13.2 Reflow soldering

Reflow soldering techniques are suitable for all QFP and SO packages.

The choice of heating method may be influenced by larger plastic QFP packages (44 leads, or more). If infrared or vapour phase heating is used and the large packages are not absolutely dry (less than 0.1% moisture content by weight), vaporization of the small amount of moisture in them can cause cracking of the plastic body. For more information, refer to the Drypack chapter in our "Quality Reference Manual" (order code 9397 750 00192).

Reflow soldering requires solder paste (a suspension of fine solder particles, flux and binding agent) to be applied to the printed-circuit board by screen printing, stencilling or pressure-syringe dispensing before package placement.

Several techniques exist for reflowing; for example, thermal conduction by heated belt. Dwell times vary between 50 and 300 seconds depending on heating method. Typical reflow temperatures range from 215 to 250 °C.

Preheating is necessary to dry the paste and evaporate the binding agent. Preheating duration: 45 minutes at 45 °C.

13.3 Wave soldering

13.3.1 QFP

Wave soldering is **not** recommended for QFP packages. This is because of the likelihood of solder bridging due to closely-spaced leads and the possibility of incomplete solder penetration in multi-lead devices.

If wave soldering cannot be avoided, the following conditions must be observed:

- A double-wave (a turbulent wave with high upward pressure followed by a smooth laminar wave) soldering technique should be used.
- The footprint must be at an angle of 45° to the board direction and must incorporate solder thieves downstream and at the side corners.

Even with these conditions, do not consider wave soldering the following packages: QFP52 (SOT379-1), QFP100 (SOT317-1), QFP100 (SOT317-2), QFP100 (SOT382-1) or QFP160 (SOT322-1).

13.3.2 SO

Wave soldering techniques can be used for all SO packages if the following conditions are observed:

- A double-wave (a turbulent wave with high upward pressure followed by a smooth laminar wave) soldering technique should be used.
- The longitudinal axis of the package footprint must be parallel to the solder flow.
- The package footprint must incorporate solder thieves at the downstream end.

13.3.3 METHOD (QFP AND SO)

During placement and before soldering, the package must be fixed with a droplet of adhesive. The adhesive can be applied by screen printing, pin transfer or syringe dispensing. The package can be soldered after the adhesive is cured.

Maximum permissible solder temperature is 260 °C, and maximum duration of package immersion in solder is 10 seconds, if cooled to less than 150 °C within 6 seconds. Typical dwell time is 4 seconds at 250 °C.

A mildly-activated flux will eliminate the need for removal of corrosive residues in most applications.

13.4 Repairing soldered joints

Fix the component by first soldering two diagonally-opposite end leads. Use only a low voltage soldering iron (less than 24 V) applied to the flat part of the lead. Contact time must be limited to 10 seconds at up to 300 °C. When using a dedicated tool, all other leads can be soldered in one operation within 2 to 5 seconds between 270 and 320 °C.

**Error correction and host interface IC for
CD-ROM (ELM)**

SAA7388**14 DEFINITIONS**

Data sheet status	
Objective specification	This data sheet contains target or goal specifications for product development.
Preliminary specification	This data sheet contains preliminary data; supplementary data may be published later.
Product specification	This data sheet contains final product specifications.
Limiting values	
Limiting values given are in accordance with the Absolute Maximum Rating System (IEC 134). Stress above one or more of the limiting values may cause permanent damage to the device. These are stress ratings only and operation of the device at these or at any other conditions above those given in the Characteristics sections of the specification is not implied. Exposure to limiting values for extended periods may affect device reliability.	
Application information	
Where application information is given, it is advisory and does not form part of the specification.	

15 LIFE SUPPORT APPLICATIONS

These products are not designed for use in life support appliances, devices, or systems where malfunction of these products can reasonably be expected to result in personal injury. Philips customers using or selling these products for use in such applications do so at their own risk and agree to fully indemnify Philips for any damages resulting from such improper use or sale.

Error correction and host interface IC for
CD-ROM (ELM)

SAA7388

NOTES

Error correction and host interface IC for
CD-ROM (ELM)

SAA7388

NOTES

Philips Semiconductors – a worldwide company

Argentina: see South America

Australia: 34 Waterloo Road, NORTH RYDE, NSW 2113,
Tel. (02) 805 4455, Fax. (02) 805 4466

Austria: Computerstr. 6, A-1101 WIEN, P.O. Box 213,
Tel. (01) 60 101-1256, Fax. (01) 60 101-1250

Belarus: Hotel Minsk Business Center, Bld. 3, r. 1211,
Volodarski Str. 6, 220050 MINSK,
Tel. (172) 200 733, Fax. (172) 200 773

Belgium: see The Netherlands

Brazil: see South America

Bulgaria: Philips Bulgaria Ltd., Energoproject, 15th floor,
51 James Bourchier Blvd., 1407 SOFIA,
Tel. (359) 2 689 211, Fax. (359) 2 689 102

Canada: PHILIPS SEMICONDUCTORS/COMPONENTS:
Tel. (800) 234-7381, Fax. (708) 296-8556

Chile: see South America

China/Hong Kong: 501 Hong Kong Industrial Technology Centre,
72 Tat Chee Avenue, Kowloon Tong, HONG KONG,
Tel. (852) 2319 7888, Fax. (852) 2319 7700

Colombia: see South America

Czech Republic: see Austria

Denmark: Prags Boulevard 80, PB 1919, DK-2300
COPENHAGEN S, Tel. (032) 88 2636, Fax. (031) 57 1949

Finland: Sinikalliontie 3, FIN-02630 ESPOO,
Tel. (358) 0-615 800, Fax. (358) 0-61580 920

France: 4 Rue du Port-aux-Vins, BP317,
92156 SURESNES Cedex,
Tel. (01) 4099 6161, Fax. (01) 4099 6427

Germany: P.O. Box 10 51 40, 20035 HAMBURG,
Tel. (040) 23 53 60, Fax. (040) 23 53 63 00

Greece: No. 15, 25th March Street, GR 17778 TAVROS,
Tel. (01) 4894 339/4894 911, Fax. (01) 4814 240

Hungary: see Austria

India: Philips INDIA Ltd, Shivsagar Estate, A Block,
Dr. Annie Besant Rd. Worli, BOMBAY 400 018
Tel. (022) 4938 541, Fax. (022) 4938 722

Indonesia: see Singapore

Ireland: Newstead, Clonskeagh, DUBLIN 14,
Tel. (01) 7640 000, Fax. (01) 7640 200

Israel: RAPAC Electronics, 7 Kehilat Saloniki St, TEL AVIV 61180,
Tel. (03) 645 04 44, Fax. (03) 648 10 07

Italy: PHILIPS SEMICONDUCTORS,
Piazza IV Novembre 3, 20124 MILANO,
Tel. (0039) 2 6752 2531, Fax. (0039) 2 6752 2557

Japan: Philips Bldg 13-37, Kohnan 2-chome, Minato-ku,
TOKYO 108, Tel. (03) 3740 5130, Fax. (03) 3740 5077

Korea: Philips House, 260-199 Itaewon-dong,
Yongsan-ku, SEOUL, Tel. (02) 709-1412, Fax. (02) 709-1415

Malaysia: No. 76 Jalan Universiti, 46200 PETALING JAYA,
SELANGOR, Tel. (03) 750 5214, Fax. (03) 757 4880

Mexico: 5900 Gateway East, Suite 200, EL PASO,
TEXAS 79905, Tel. 9-5(800) 234-7831, Fax. (708) 296-8556

Middle East: see Italy

Netherlands: Postbus 90050, 5600 PB EINDHOVEN, Bldg. VB,
Tel. (040) 2783749, Fax. (040) 2788399

New Zealand: 2 Wagener Place, C.P.O. Box 1041, AUCKLAND,
Tel. (09) 849-4160, Fax. (09) 849-7811

Norway: Box 1, Manglerud 0612, OSLO,
Tel. (022) 74 8000, Fax. (022) 74 8341

Philippines: PHILIPS SEMICONDUCTORS PHILIPPINES Inc.,
106 Valero St. Salcedo Village, P.O. Box 2108 MCC,
MAKATI, Metro MANILA,
Tel. (63) 2 816 6380, Fax. (63) 2 817 3474

Poland: Ul. Lukiska 10, PL 04-123 WARSZAWA,
Tel. (022) 612 2831, Fax. (022) 612 2327

Portugal: see Spain

Romania: see Italy

Singapore: Lorong 1, Toa Payoh, SINGAPORE 1231,
Tel. (65) 350 2000, Fax. (65) 251 6500

Slovakia: see Austria

Slovenia: see Italy

South Africa: S.A. PHILIPS Pty Ltd.,
195-215 Main Road Martindale, 2092 JOHANNESBURG,
P.O. Box 7430 Johannesburg 2000,
Tel. (011) 470-5911, Fax. (011) 470-5494

South America: Rua do Rocio 220 - 5th floor, Suite 51,
CEP: 04552-903-SAO PAULO-SP, Brazil,
P.O. Box 7383 (01064-970),
Tel. (011) 821-2333, Fax. (011) 829-1849

Spain: Balmes 22, 08007 BARCELONA,
Tel. (03) 301 6312, Fax. (03) 301 4107

Sweden: Kottbygatan 7, Akalla. S-16485 STOCKHOLM,
Tel. (0) 8-632 2000, Fax. (0) 8-632 2745

Switzerland: Allmendstrasse 140, CH-8027 ZÜRICH,
Tel. (01) 488 2211, Fax. (01) 481 77 30

Taiwan: PHILIPS TAIWAN Ltd., 23-30F, 66,
Chung Hsiao West Road, Sec. 1, P.O. Box 22978,
TAIPEI 100, Tel. (886) 2 382 4443, Fax. (886) 2 382 4444

Thailand: PHILIPS ELECTRONICS (THAILAND) Ltd.,
209/2 Sanpavuth-Bangna Road Prakanong, BANGKOK 10260,
Tel. (66) 2 745-4090, Fax. (66) 2 398-0793

Turkey: Talatpasa Cad. No. 5, 80640 GÜLTEPE/ISTANBUL,
Tel. (0212) 279 2770, Fax. (0212) 282 6707

Ukraine: PHILIPS UKRAINE,
2A Akademika Koroleva str., Office 165, 252148 KIEV,
Tel. 380-44-4760297, Fax. 380-44-4766991

United Kingdom: Philips Semiconductors LTD.,
276 Bath Road, Hayes, MIDDLESEX UB3 5BX,
Tel. (0181) 730-5000, Fax. (0181) 754-8421

United States: 811 East Arques Avenue, SUNNYVALE,
CA 94088-3409, Tel. (800) 234-7381, Fax. (708) 296-8556

Uruguay: see South America

Vietnam: see Singapore

Yugoslavia: PHILIPS, Trg N. Pasica 5/v, 11000 BEOGRAD,
Tel. (381) 11 825 344, Fax. (359) 211 635 777

Internet: <http://www.semiconductors.philips.com/ps/>

For all other countries apply to: Philips Semiconductors,
Marketing & Sales Communications, Building BE-p,
P.O. Box 218, 5600 MD EINDHOVEN, The Netherlands,
Fax. +31-40-2724825

SCDS48

© Philips Electronics N.V. 1996

All rights are reserved. Reproduction in whole or in part is prohibited without the prior written consent of the copyright owner.

The information presented in this document does not form part of any quotation or contract, is believed to be accurate and reliable and may be changed without notice. No liability will be accepted by the publisher for any consequence of its use. Publication thereof does not convey nor imply any license under patent- or other industrial or intellectual property rights.

Printed in The Netherlands

517021/1200/01/pp60
Document order number:

Date of release: 1996 Apr 26
9397 750 00808