TITLE: 13219A DISC SERVICE UNIT
MANUAL

PART NUMBER: 13219-90000

MICROFICHE:

PRINT DATE: 9/78

UPDATE:

PRINTED IN THE U.S.A.

* * * * *
* The product related to this manual is no longer in production at the Hewlett- *
* Packard Corporation. The manual is maintained on a microfiche master by Direct *
* Marketing Division. As a service to our customers we are providing a hardcopy *
* print of the microfiche. The print is produced using a Microfiche Printing System. In *
* addition, we are providing a duplicate of the microfiche to provide maximum *
* flexibility for our customers. *
* * * * * *
* * * * *

LIST OF EFFECTIVE PAGES

Changed pages are identified by a change number adjacent to the page number. Changed information is indicated by a vertical line in the margin of the page. Original pages (Change 0) do not include a change number. Insert latest changed pages and destroy superseded pages.

Change 0 (Original) SEP 1978

All pages in this edition are original.

TABLE OF CONTENTS

Section	Page	Section	Page
I GENERAL INFORMATION		IV THEORY OF OPERATION	
1-1. Introduction	1-1	4-1. Introduction	4-1
1-3. General Description	1-1	4-3. Functional Description	4-1
1-8. Identification	1-1	4-8. Detailed Circuit Descriptions	4-1
1-11. Specifications	1-1	4-9. Strobe and Clock Generation	4-1
		4-13. Set Head and Set Cylinder Commands	4-1
II INSTALLATION		4-19. Control Command	4-3
2-1. Introduction	2-1	4-25. Outbus Commands	4-3
2-3. Unpacking and Inspection	2-1		
2-5. Cable Connections	2-1	V MAINTENANCE	
2-7. Installation Considerations	2-1	5-1. Introduction	5-1
2-8. Disc Drive Status	2-1	5-3. Preventive Maintenance	5-1
2-10. Disc Service Unit Control Settings	2-1	5-4. Inspection	5-1
2-12. Shipping Instructions	2-1	5-6. Cleaning	5-1
		5-8. Performance Checkout	5-1
III OPERATION		5-10. Troubleshooting	5-1
3-1. Introduction	3-1		
3-3. Front Panel Features	3-1	VI REPLACEABLE PARTS	
3-5. Operation	3-1	6-1. Introduction	6-1
		6-5. Ordering Information	6-1

LIST OF ILLUSTRATIONS

Figure	Title	Page	Figure	Title	Page
1-1.	HP 13219A Disc Service Unit	1-0	5-4.	Clock Generator and Set Cylinder Circuits, Schematic Diagram	5-7
3-1.	Front Panel Features	3-2	5-5.	Control and Access Circuits, Schematic Diagram	5-9
3-2.	Control Setting Sequence and Normal Drive Responses	3-4	5-6.	One Cylinder Increments Circuit, Schematic Diagram	5-11
4-1.	Service Unit Block Diagram	4-0	5-7.	Address and Drive Condition Circuits, Schematic Diagram	5-13
4-2.	Timing Diagram for Strobe and Clock Pulses	4-2	6-1.	HP 13219A Disc Service Unit Parts Location Diagram	6-2
5-1.	Logic PCA A1 Parts Location Diagram	5-3			
5-2.	Deleted	5-4			
5-3.	Indicator PCA A2 Parts Location Diagram	5-5			

LIST OF TABLES

Table	Title	Page	Table	Title	Page
1-1.	HP 13219A Disc Service Unit Specifications	1-1	5-3.	Deleted	5-4
3-1.	Binary Display of Specific Read/Write Faults	3-1	6-1.	HP 13219A Disc Service Unit Replaceable Parts	6-3
5-1.	Logic PCA A1 Replaceable Parts	5-2	6-2.	Reference Designations and Abbreviations	6-3
5-2.	Indicator PCA A2 Replaceable Parts	5-4	6-3.	Code List of Manufacturers	6-4

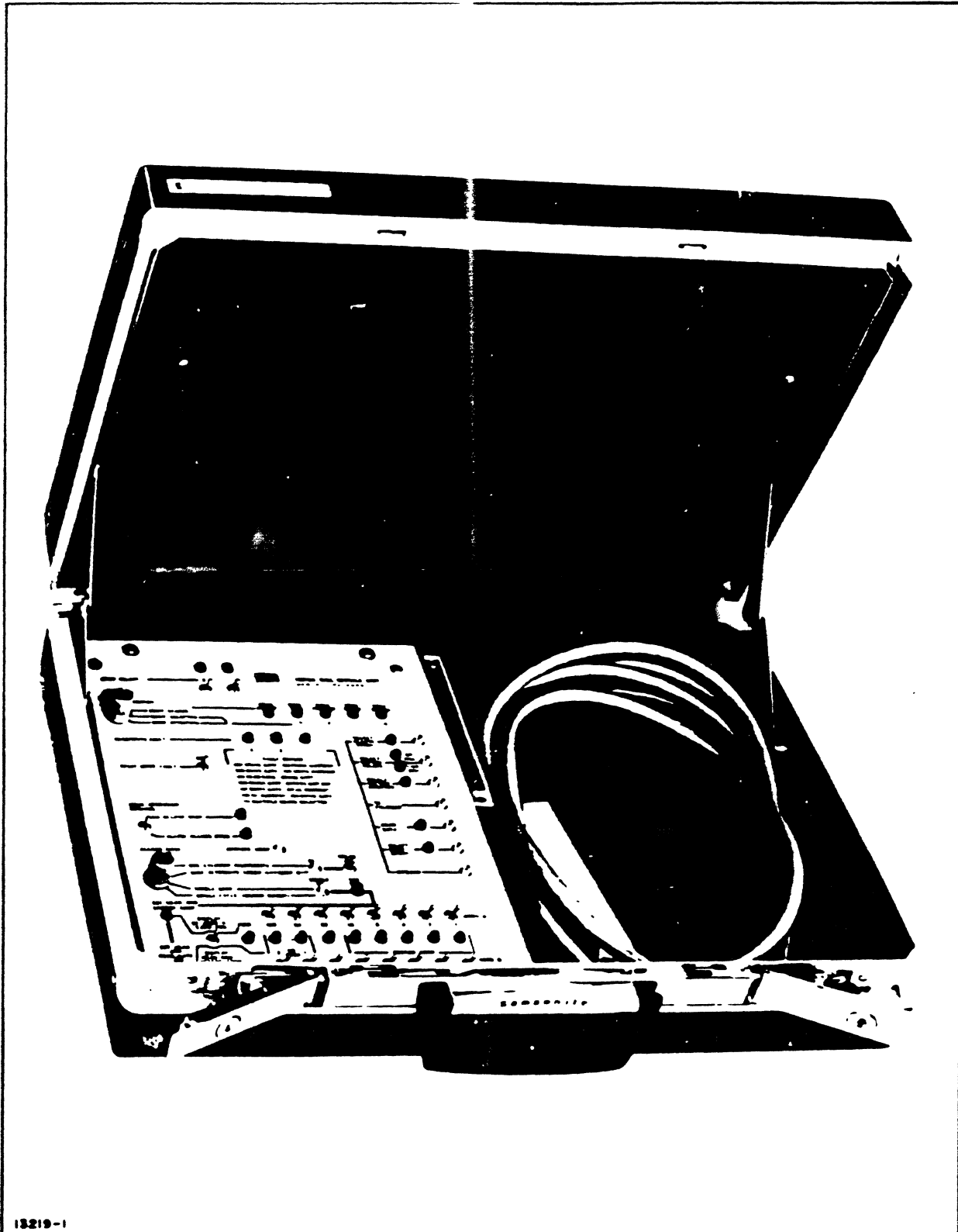

Figure 1-1. HP 13219A Disc Service Unit

SECTION I

GENERAL INFORMATION

1-1. INTRODUCTION.

1-2. This operating and service manual provides general information, installation, operation, theory of operation, maintenance, and replaceable parts information for the Hewlett-Packard 13219A Disc Service Unit. See figure 1-1.

1-3. GENERAL DESCRIPTION.

1-4. The HP 13219A Disc Service Unit is a portable device designed as an aid to on-site troubleshooting of HP 7900 Series Disc Drives. The service unit applies simulated controller signals to the disc drive and processes the drive responses for display.

1-5. Simulated signals are produced manually and semi-automatically to operate the disc drive in quiescent and dynamic conditions. Disc drive operations are limited to addressing, accessing, and reading sequences.

1-6. No write operations are performed, and the read operation is limited to monitoring the serial data that come off the disc. However, the service unit does provide direct display of specific read/write faults that are detected within the disc drive.

1-7. Response signals from the disc drive are displayed either on the service unit front panel or on an attached oscilloscope. Relatively static parameters (e.g., drive address, drive status, etc) are displayed by indicator lights on the service unit front panel. Dynamic parameters (i.e., timing and control signals) are presented at test points on the service unit front panel for monitoring with an oscilloscope.

1-8. IDENTIFICATION.

1-9. Hewlett-Packard identifies each unit with a two-section serial number (0000A-00000). The first four digits are a serial number prefix used to identify a particular unit configuration. The letter identifies the country in which the unit was manufactured. The last five digits identify each specific unit. If the serial number prefix on the unit does not

agree with the prefix on the title page of this manual, there are differences between that unit and the unit described in this manual. These differences are described in manual supplements available at the nearest HP Sales and Service Office.

1-10. Printed-circuit assembly (PCA) revisions are identified by a letter, a series code, and a division code marked beneath the part number on the PCA (A-0000-00). The letter identifies the revision of the etched trace pattern on the unloaded PCA. The four-digit series code pertains to the electrical characteristics of the loaded PCA and the positions of the components. The two-digit division code identifies the division of Hewlett-Packard that manufactured the PCA. If the series code number does not correspond exactly with the code number on the schematic diagrams in this manual, the PCA differs from the one described in this manual. These differences are covered in manual supplements available at the nearest HP Sales and Service Office.

1-11. SPECIFICATIONS.

1-12. Specifications for the HP 13219A Disc Service Unit are listed in table 1-1.

Table 1-1. HP 13219A Disc Service Unit Specifications

<p>Description: Attache-case enclosed unit to aid on-site troubleshooting of HP 7900 Series Disc Drives.</p> <p>Logic Levels: High = +5 Vdc; Low = 0 Vdc</p> <p>Power Requirements: 5V nominal, 1.7A maximum, obtained from disc drive.</p> <p>Accessories Included: 8-foot interconnecting cable.</p> <p>Weight: 10 lbs (4,54 kg)</p> <p>Dimensions: 18 x 12 x 5 in. (457,2 x 304,8 x 127 mm)</p>
--

SECTION II

INSTALLATION

2-1. INTRODUCTION.

2-2. This section contains information on unpacking, inspection and installation for the HP 13219A Disc Service Unit.

2-3. UNPACKING AND INSPECTION.

2-4. If the shipping carton is damaged upon receipt, request that the carrier's agent be present when the unit is unpacked. Inspect the unit for damage (scratches, dents, broken parts, etc.) If the unit is damaged and fails to meet specifications, notify the carrier and the nearest HP Sales and Service Office immediately. (Sales and Service Offices are listed at the back of this manual.) Retain the shipping container and the padding material for the carrier's inspection. Hewlett-Packard will arrange for repair or replacement of the damaged unit without waiting for any claims against the carrier to be settled.

2-5. CABLE CONNECTIONS.

2-6. During use, the service unit is connected to the disc drive to be tested by connecting service unit cable W4P2 to service connector A6J1 at the left side of the disc drive chassis. The cable should be oriented with the "cable-end" of cable connectors facing the front of the disc drive and service unit. The service unit obtains the required +5 Vdc and ground operating voltages from the disc drive to which it is connected during servicing.

2-7. INSTALLATION CONSIDERATIONS.

2-8. DISC DRIVE STATUS.

2-9. The disc drive to be tested must be taken off-line for servicing. The disc drive can be taken off-line by removing the I/O connector cable at the back of the disc drive.

If the disc drive to be tested is last in a series of parallel-connected units, the termination circuit board at the back of the disc drive must be re-installed in the last remaining disc drive in the series.

2-10. DISC SERVICE UNIT CONTROL SETTINGS.

2-11. When the disc service unit is initially connected to a disc drive and when not actually in use during servicing, the DRIVE OPERATION CONTROL switch should be set to ACCESS STOP to prevent any accidental initiation of operations.

2-12. SHIPPING INSTRUCTIONS.

2-13. If the unit is to be shipped to Hewlett-Packard for service or repair, attach a tag to the unit identifying the owner and indicating the service or repair to be accomplished. Include the model number and full serial number of the unit.

2-14. Place the unit in the original container if available. If the original container is not available, a suitable container and packing material can be purchased from a local Hewlett-Packard Sales and Service Office.

2-15. If the original container is not used, wrap the unit in heavy paper and place it in an inner container. Place adequate packing material around all sides of the unit and place a cardboard strip over the front panel. Place the unit and inner container in a heavy carton or wooden box and bind with strong tape or metal bands. Mark the shipping container "FRAGILE."

Note

In any correspondence, identify the unit by model number and serial number prefix. Refer any questions to the nearest Hewlett-Packard Sales and Service Office.

SECTION III OPERATION

3-1. INTRODUCTION.

3-2. This section contains information for operating the HP 13219A Disc Service Unit.

3-3. FRONT PANEL FEATURES.

3-4. Front-panel features are described in figure 3-1. The numbered panel features are described in the corresponding, numbered paragraphs below the illustration.

3-5. OPERATION.

3-6. Figure 3-2 describes the recommended sequence for setting controls and the responses that should result when the service unit is connected to a properly operating disc drive. Analysis of the responses obtained from the disc drive under test can identify a malfunctioning section of the disc drive.

Table 3-1. Binary Display of Specific Read Write Faults

READ/WRITE FAULT	BINARY DISPLAY 4 2 1
Proper operation.	0 0 0
No erase gate with erase current flowing.	0 0 1
No erase current flowing with write gate.	0 1 0
Simultaneous read gate and erase gate.	0 1 1
More than one head selected.	1 0 0
Write gate present but no ac write current.	1 0 1
Write current flowing in write driver without write gate.	1 1 0
Erase gate without access ready.	1 1 1

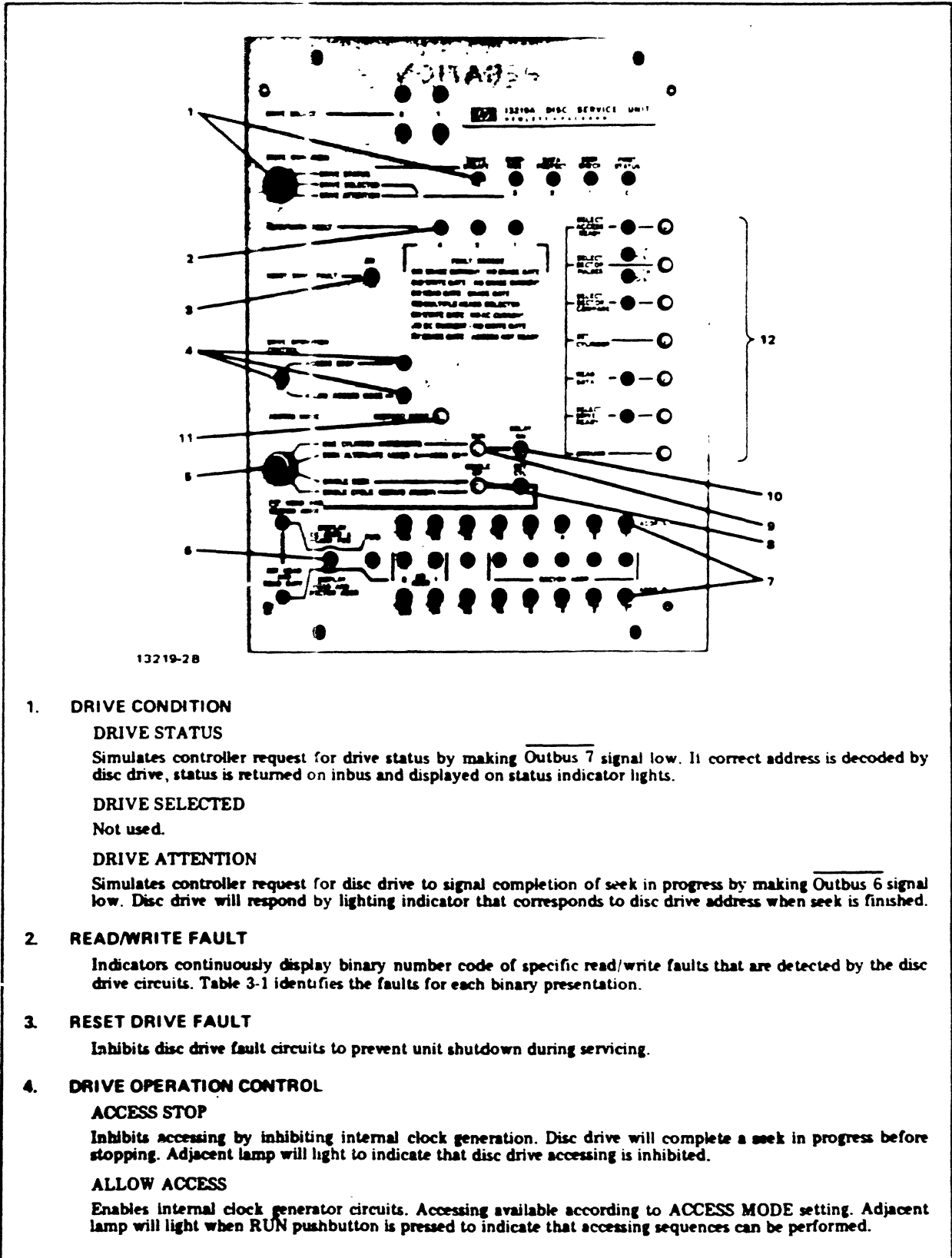

13219-28

1. DRIVE CONDITION

DRIVE STATUS

Simulates controller request for drive status by making Outbus 7 signal low. If correct address is decoded by disc drive, status is returned on inbus and displayed on status indicator lights.

DRIVE SELECTED

Not used.

DRIVE ATTENTION

Simulates controller request for disc drive to signal completion of seek in progress by making Outbus 6 signal low. Disc drive will respond by lighting indicator that corresponds to disc drive address when seek is finished.

2. READ/WRITE FAULT

Indicators continuously display binary number code of specific read/write faults that are detected by the disc drive circuits. Table 3-1 identifies the faults for each binary presentation.

3. RESET DRIVE FAULT

Inhibits disc drive fault circuits to prevent unit shutdown during servicing.

4. DRIVE OPERATION CONTROL

ACCESS STOP

Inhibits accessing by inhibiting internal clock generation. Disc drive will complete a seek in progress before stopping. Adjacent lamp will light to indicate that disc drive accessing is inhibited.

ALLOW ACCESS

Enables internal clock generator circuits. Accessing available according to ACCESS MODE setting. Adjacent lamp will light when RUN pushbutton is pressed to indicate that accessing sequences can be performed.

Figure 3-1. Front Panel Features

5. ACCESS MODE**ONE CYLINDER INCREMENTS**

Simulates controller instructions for disc drive to continuously seek, one cylinder at a time, between cylinder 000 and 202. Automatic operation will begin when RUN pushbutton is pressed. Head and sector addresses are set with ADDR B switches; cylinder addressing is automatic. Legal head and sector addresses are 0 through 3 and 00 through 23, respectively. Disc drive will momentarily light SEEK CHECK lamp if illegal address is set. Operation is halted by setting DRIVE OPERATION CONTROL switch to ACCESS STOP or by setting ACCESS MODE switch to a different position.

SEEK ALTERNATE (ADDR A ↔ ADDR B)

Simulates controller instructions for disc drive to alternately seek to cylinder addresses set with ADDR A and ADDR B switches. Legal addresses are 000 through 202. Automatic operation will begin when RUN pushbutton is pressed. Disc drive will momentarily light SEEK CHECK lamp if illegal address is set. Control line is held high in this mode.

SINGLE SEEK

Simulates controller accessing instructions given in single steps. SET CYL lamp, SET HEAD AND SECTOR ADDR lamp, and SET HEAD AND READ GATE lamp will light in succession as SINGLE OP pushbutton is pressed, to indicate the step of the accessing sequence that will take place when SINGLE OP is next pressed (RUN pushbutton must be pressed before SINGLE OP pushbutton is pressed first time.) Desired cylinder address is set with ADDR A switches; head and sector addresses are set with ADDR B switches. Legal cylinder addresses are 000 through 202; head and sector addresses are 0 through 3 and 00 through 23, respectively. Difference between addressed cylinder and carriage position or head and sector addresses can be displayed on address lights according to position of DISPLAY switch. Disc drive will light SEEK CHECK lamp if illegal address is set.

SINGLE CYCLE (SERVO INHIBIT)

Simulates controller accessing instructions given in single steps (although inhibited servo prevents seek operation).

6. DISPLAY

Selects address to be displayed on address lamps. When DISPLAY is set to SK ADDR A - CARR POS, lamps will momentarily display difference between desired cylinder address and present carriage position. When DISPLAY is set to HEAD AND SECTOR ADDR, address lamps display the current head and sector address.

7. ADDR A AND ADDR B

Allow manual selection of cylinder, head, and sector addresses. When ACCESS MODE switch is set to ONE CYLINDER INCREMENTS, only ADDR B switches are used to select head and sector addresses; cylinder addressing is automatic. When ACCESS MODE switch is set to SEEK ALTERNATE, switches select the two alternative cylinder addresses; no head or sector addresses are selected. When ACCESS MODE switch is set to SINGLE SEEK, ADDR A switches select cylinder address; ADDR B switches select head and sector addresses. Bit positions 128 and 64 are used for head address. Bit positions 16 through 1 are used for sector addresses. Legal cylinder addresses are 000 through 202; head and sector addresses are 0 through 3 and 00 through 23, respectively.

8. SINGLE OP

Initiates each single step of accessing sequence when ACCESS MODE switch is set to SINGLE SEEK (after RUN pushbutton is pressed).

9. RUN

Initiates automatic accessing sequence when ACCESS MODE switch is set to ONE CYLINDER INCREMENTS or SEEK ALTERNATE. Initializes accessing circuits when ACCESS MODE switch is set to SINGLE SEEK or SINGLE CYCLE.

10. DELAY

Provides 100-ms delay between operating cycles of service unit when ACCESS MODE switch is set to ONE CYLINDER INCREMENTS or SEEK ALTERNATE.

11. RESTORE HOME

Simulates controller instruction to return to cylinder address 000 by making Set Cylinder and Set Head signals low simultaneously. Operational only during SINGLE SEEK and ONE CYLINDER INCREMENTS access modes after RUN pushbutton is pressed.

12. TEST POINTS

Permit oscilloscope monitoring of significant disc drive parameters. Adjacent lights provide visual display of most monitored parameters and identify which disc has been selected according to head address selected by ADDR B switches.

Figure 8-1. Front Panel Features (Continued)

4. Set ACCESS MODE switch to desired accessing operation; set ADDR A and ADDR B switches as required.
 - a. In ONE CYLINDER INCREMENTS position, set desired head and sector addresses with ADDR B switches. Legal head and sector addresses are 0 through 3 and 00 through 23, respectively.
 - b. In SEEK ALTERNATE position, set desired alternate cylinder addresses with ADDR A and ADDR B switches. Legal addresses are 000 through 202.
 - c. In SINGLE SEEK position, set desired cylinder address with ADDR A switches. Set desired head and sector address with ADDR B switches. Legal cylinder addresses are 000 through 202, head and sector addresses are 0 through 3 and 00 through 23, respectively.

SET CYL lamp will light to indicate that Set Cylinder command will be issued at next step
5. Press RUN pushbutton (and SINGLE OP pushbutton as appropriate). ACCESS MODE lamp will light when RUN pushbutton is pressed to indicate that accessing sequences can be performed.
 - a. When the ACCESS MODE switch is set to ONE CYLINDER INCREMENTS, disc drive should begin seeking, one cylinder at a time, between cylinders 000 and 202. LOW DISC or UP DISC indicator should light according to head addressed. Disc drive signals should be presented at SELECT SECTOR COMPARE, READ DATA, and SELECT ACCESS READY test points.
 - b. When ACCESS MODE switch is set to SEEK ALTERNATE, disc drive should begin alternately seeking between addressed cylinders. Disc drive signals should be presented at SET CYLINDER and SELECT ACCESS READY test points. (Although no head or sector addressing occurs, head and sector-related signals should be presented according to last head and sector addressed.)
 - c. When ACCESS MODE switch is set to SINGLE SEEK, disc drive should seek to addressed cylinder. Address lamps should momentarily display difference between desired cylinder address and current carriage position if DISPLAY switch is set to SK ADDR A—CARR POS. SET CYLINDER lamp will go off and SET HEAD AND SECTOR ADDR lamp will light to indicate that Set Head and Read Gate commands will be issued when SINGLE OP pushbutton is next pressed.

When SINGLE OP pushbutton is again pressed, disc drive should select the addressed head and sector. Address lamps should display desired head and sector addresses if DISPLAY switch is set to HEAD AND SECTOR ADDR. LOW DISC or UP DISC indicator should light according to head addressed. Disc drive signal should be presented at SELECT SECTOR COMPARE test point. SET HEAD AND SECTOR ADDR lamp will go off and SET HEAD AND READ GATE and READ DATA lamps will light to indicate that Read command is issued and disc drive will read data. Serial data should be presented at READ DATA test point.

When SINGLE OP pushbutton is again pressed, SET HEAD AND READ GATE and READ DATA lamps will go off and SET CYL lamp will light to indicate that Set Cylinder command will be issued when SINGLE OP pushbutton is next pressed.
 - d. When ACCESS MODE switch is set to SINGLE CYCLE, carriage movement is prevented by inhibited servo (If RESET DRIVE FAULT switch is off, carriage will retract after approximately 1 second, carriage will reload after 30 seconds if switch is reset to ON.)
6. Set DRIVE OPERATION CONTROL switch to ACCESS STOP to halt operation. Adjacent lamp will light to indicate that accessing operations are inhibited.

Figure 3-2. Control Setting Sequence and Normal Drive Responses (Continued)

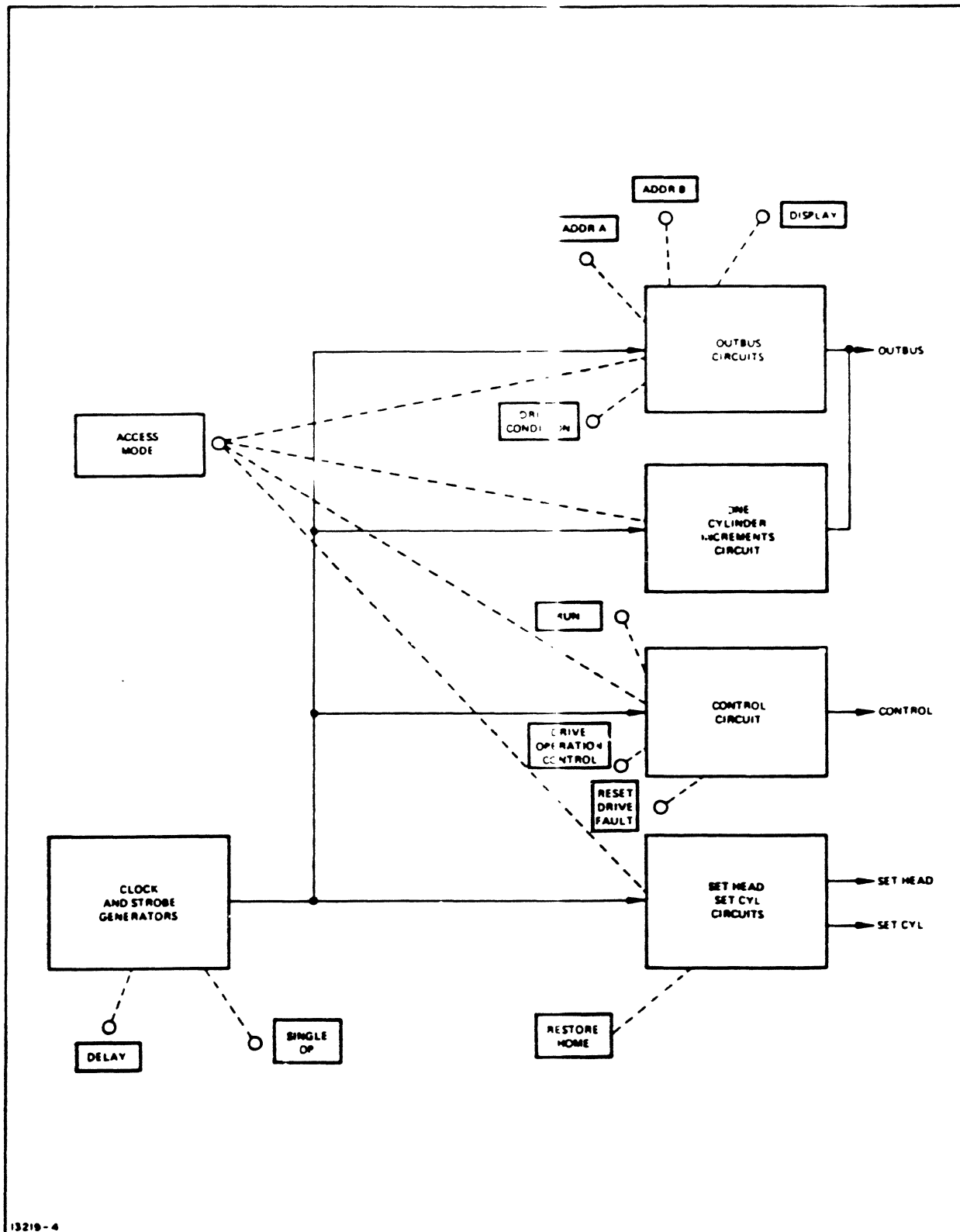

Figure 4-1. Service Unit Block Diagram

SECTION IV THEORY OF OPERATION

4-1. INTRODUCTION.

4-2. This section describes the theory of operation of the HP 13219A Disc Service Unit.

4-3. FUNCTIONAL DESCRIPTION.

4-4. The service unit aids troubleshooting of HP 7900A Series Disc Drives by applying simulated controller signals to the disc drive and processing the responses for display. The service unit permits manual or semi-automatic control of the disc drive. Analysis of the disc drive responses will verify proper disc drive operation or help isolate malfunctions.

4-5. Front-panel controls allow step-by-step, manual selection of various commands to operate the disc drive under simulated, semi-automatic conditions. Each command and subsequent operating sequence exercises a particular section of the disc drive circuits. The responses of the disc drive, either as signals sent back to the service unit or as an operation based on command interpretation, will indicate proper operation or malfunctions of the disc drive. (See figure 4-1.)

4-6. Signals from the disc drive that are normally sent to the disc drive controller, such as status and disc timing, are available at the service unit front panel. Additionally, significant signals internal to the disc drive are available. Therefore, with the service unit connected to service connector A6J1 of the disc drive, no access to the drive interior is required for trouble analysis.

4-7. The signals are displayed either on the service unit front panel or on a connected oscilloscope. Relatively static parameters (e.g., drive address, drive status, etc.) are displayed by indicator lights on the service unit front panel. Dynamic parameters (i.e., timing and control signals) are presented at test points on the service unit front panel for monitoring with an oscilloscope.

4-8. DETAILED CIRCUIT DESCRIPTIONS.

4-9. STROBE AND CLOCK GENERATION.

4-10. The output of the 100-kHz oscillator is divided by two by divider U93A and applied simultaneously to strobe generator U65A and clock generator U93/U83. See figure 5-4.

4-11. The strobe generator generates a short-duration gating pulse at the middle of each clock period produced by the clock generator. Negative-going excursions of the 50-kHz signal, applied simultaneously to a U65A input and the U74F input, will be inverted by U74F and will

charge capacitor C5. At the succeeding positive-going excursion both inputs to U65A will momentarily be high and the gate will output a negative-going, short-duration pulse at each positive-going excursion of the 50-kHz oscillator signal.

4-12. The 50-kHz oscillator signal is also applied to divider U93B of the clock generator circuit. The divider circuit will simultaneously provide divide-by-two, divide-by-four, and divide-by-eight outputs to decoder U83. Decoder U83 will provide eight outputs that reflect the signal combinations at the three inputs. Figure 4-2 shows decoder input combinations and relative timing of resultant clock periods and strobe pulses.

4-13. SET HEAD AND SET CYLINDER COMMANDS.

4-14. The Set Cylinder line is normally low during clock period 3. The Set Head line is normally low during clock period 6. The only exceptions are (1) when a Restore Home command is issued by making Set Cylinder and Set Head lines low simultaneously, and (2) during the seek alternate access mode, the Set Head command is not issued. See figure 5-4.

4-15. In the one cylinder increments and seek alternate access modes, clock periods are continuously generated; therefore, Set Cylinder will be low each time clock period 3 occurs. Similarly, Set Head will be low each time clock period 6 occurs (but only in the one cylinder increments mode). In the single seek and single cycle access modes, however, issuance of Set Cylinder and Set Head commands is more complex.

4-16. When the ACCESS MODE switch is initially set to SINGLE SEEK or SINGLE CYCLE, Clock Inhibit Latch FF U96B will be set; the clock generator input will be inhibited by "nand" gate U95C, thus no clock signals will be generated. When the SINGLE OP pushbutton is first pressed, Pushbutton Latch FF U86B will be set, which clears the Clock Inhibit Latch FF. As a result, clock periods 1, 2, 3, and 4 will be generated. At clock period 4, "nor" gate U84C will be low, the Clock Inhibit Latch FF will be set, and the clock generator input will be inhibited until the SINGLE OP pushbutton is pressed again.

4-17. When the SINGLE OP pushbutton is pressed the second time, clock periods 5, 6, and 7 will be generated. At clock period 7, "nor" gate U84C will again be low, which will again inhibit the clock generator input.

4-18. Also during clock period 7, Delay one-shot U94 will be triggered. If the DELAY switch is set to ON, the clock generator input will be inhibited by "nand" gate U84B for the 100 ms duration of the Delay one-shot output.

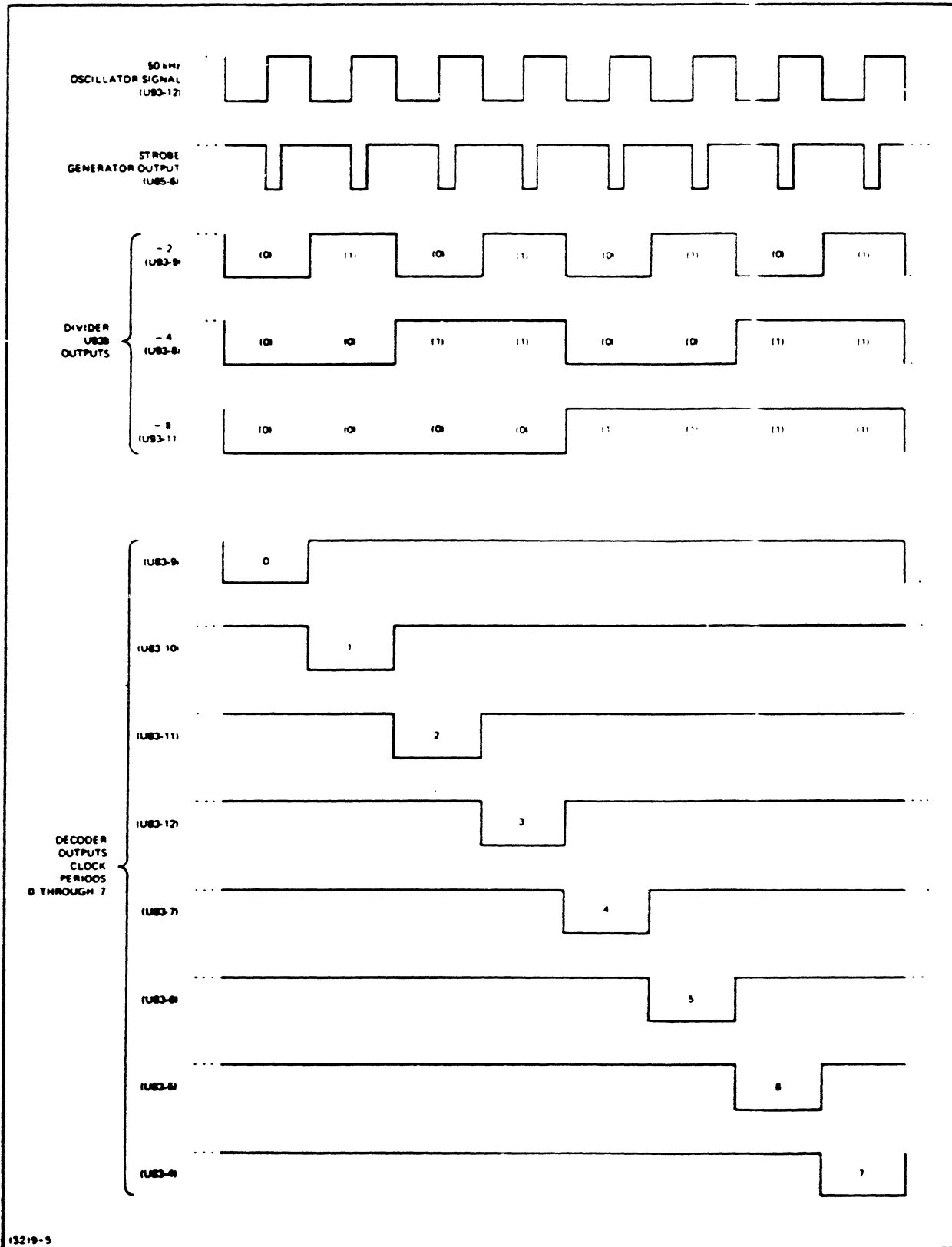

Figure 4-2. Timing Diagram for Strobe and Clock Pulses

4-19. CONTROL COMMAND.

4-20. The Control command is normally issued during clock periods 0, 1, 4, and 7. However, Access Op Latch FF U96A, which initiates and halts accessing sequences, also affects issuance of Control commands. See figure 5-5.

4-21. When the DRIVE OPERATION CONTROL switch is set to ACCESS STOP, Access Op Latch FF U96A will be held in the clear state. As a result, the divider circuit of clock generator U93 will be held cleared, which inhibits generation of any clock signals. Additionally, Control is held low.

4-22. The Access Op Latch FF is also cleared by power-on reset circuit U65B when the service unit is initially connected to the disc drive and also by the ACCESS MODE switch each time a new access mode is selected. (The non-shorting feature of the switch produces a clear pulse when switched between positions.)

4-23. When the DRIVE OPERATION CONTROL switch is set to ALLOW ACCESS, the Access Op Latch FF is no longer held in the clear state. When the RUN pushbutton is pressed, the Access Op Latch will be set, the clear input of the clock generator divider circuit will be released, clock signals will be generated, and Control will go low at the appropriate intervals.

4-24. When the ACCESS MODE switch is set to SEEK ALTERNATE, the clock generator signals used to make Control low are inhibited by "or" gate U44A. Therefore Control remains high in the seek alternate mode.

4-25. OUTBUS COMMANDS.

4-26. The eight outbus lines send various signals to the disc drive under test at appropriate times. Specifically, the desired cylinder address is sent during clock period 3, the head and sector addresses are sent during clock period 6, and individual lines are made high to request status information from the drive.

4-27. When the ACCESS MODE switch is set to ONE CYLINDER INCREMENTS, the output of Reversible Counter U26/U46 is sent as the desired cylinder address. The counter is initially loaded with all "1" bits by power-on reset circuit U65B or by ACCESS MODE switch. At clock period 1, the count direction is determined; at clock period 2, the count pulse is issued; at clock period 3, the cylinder address is placed on the outbus; and at clock period 6, the head and sector addresses set by the ADDR B switches are placed on the outbus. See figure 5-6.

4-28. With all counter bits at "1" the output of "nand" gate U35 will be low and counter direction control circuit U44C-D/U55A-D will make one input of "nand" gate U55C high. During clock period 2, "nand" gate U55C will apply the "count up" pulse to the down input of the counter.

4-29. The technique of using "1111111" to equal cylinder address 000 and applying count up pulses to the down input of the counter is used to maintain compatibility with the logic used between the disc drive and connected devices. Thus, when the first count up pulse is applied, the address for cylinder 1 is represented by 11111110. Similarly, the address for cylinder 2 is represented by 11111101, etc.

4-30. When the counter reaches cylinder 202, the counter direction control circuit will make one input of "nand" gate U55B high, and succeeding count pulses will be applied as "count down" pulses to the up input of the counter. As a result, cylinder addressing will reverse direction toward cylinder 000.

4-31. In the seek alternate access mode, Switch Register Select FF U86A alternately places the cylinder addresses set by the ADDR A and ADDR B switches on the outbus during clock period 3. See figure 5-7.

4-32. In the single seek and single cycle access modes, the cylinder address set by the ADDR A switches is placed on the outbus by "nand" gate U76C during clock period 3. The head and sector addresses set by the ADDR B switches are placed on the outbus by "nor" gate U53C during clock period 6.

SECTION V MAINTENANCE

5-1. INTRODUCTION.

5-2. This section contains maintenance information for the HP 13219A Disc Service Unit.

5-3. PREVENTIVE MAINTENANCE.

5-4. INSPECTION.

5-5. The service unit should be periodically inspected for signs of mechanical and electrical defects. Electronic components that show signs of overheating, leakage, frayed insulation, and other signs of deterioration should be checked and a thorough investigation of the associated circuitry should be made to verify proper operation. Mechanical parts should be inspected for excessive wear, looseness, misalignment, corrosion, and other signs of deterioration.

5-6. CLEANING

5-7. The service unit should be kept free of dust, moisture, grease and foreign matter to ensure trouble-free

operation. A dry, clean cloth, a soft-bristle brush, or a cloth saturated with diluent lacquer or a similar cleaning compound may be used.

5-8. PERFORMANCE CHECKOUT.

5-9. Proper performance of the service unit can be verified by connecting the service unit to a properly operating HP 7900 Disc Drive and confirming normal drive responses as given in figure 3-2.

5-10. TROUBLESHOOTING.

5-11. Analysis of the responses obtained from the performance checkout in paragraph 5-8 can identify a malfunctioning section of the service unit. For example, if the one cylinder diagnostics access mode does not operate, the malfunction is probably located in the reversible counter circuitry shown in figure 5-6.

Table 5-1. Logic PCA A1 Replaceable Parts

REFERENCE DESIGNATION	HP PART NO.	DESCRIPTION	MFR CODE	MFR PART NO.
C1, 5, 6, 21	0160-0153	CAPACITOR, fxd, My, 0.001 μ F, 10%, 200 VDCW	56289	192P10292-PTS
C2	0160-0161	CAPACITOR, fxd, My, 0.01 μ F, 10%, 200 VDCW	56289	191P10393-PTS
*C2	0160-3533	CAPACITOR, fxd, mica, 470 pF, 5%, 100 VDCW	00853	RDM15F471J1C
C3, 8, 9	0180-1746	CAPACITOR, fxd, elect, 15 μ F, 10%, 20 VDCW	28480	0180-1746
C4	0160-0194	CAPACITOR, fxd, My, 0.015 μ F, 10%, 200 VDCW	56289	192P15392-PTS
C7	0180-0374	CAPACITOR, fxd, tant, 10 μ F, 10%, 20 VDCW	56289	150D106X902082-DYS
C10 thru C21	0160-2055	CAPACITOR, fxd, cer, 0.01 μ F, +80-20%, 100 VDCW	56289	C023F101F103ZS22-CDM
CR1, 2	1901-0040	DIODE, silicon, 30 mA, 30 WV	07263	FDG1088
R1, 94, 97, 100, 103, 106, 113, 116, 119, 127	0757-0418	RESISTOR, fxd, met flm, 619 ohms, 1%, 1/8W	28480	0757-0418
R2, 95, 98, 101, 104, 107, 114, 117, 120, 126	0757-0428	RESISTOR, fxd, met flm, 1.62k, 1%, 1/8W	28480	0757-0428
R3, 8, 12, 19, 131	0683-3915	RESISTOR, fxd, comp, 390 ohms, 5%, 1/4W	01121	CB 3915
R4, 16, 17, 18, 20, 25, 28, 30 thru 37, 83 thru 87, 111, 112, 118, 121, 124, 128, 133	0683-1025	RESISTOR, fxd, comp, 1000 ohms, 5%, 1/4W	01121	CB 1025
R5	0683-2735	RESISTOR, fxd, comp, 27k, 5%, 1/4W	01121	CB 2735
*R5	0698 3161	RESISTOR, fxd, met flm, 38.3k, 1%, 1/8W	28480	0698-3161
R6, 7, 10, 11, 13, 14, 22, 23, 24, 29, 38 thru 53, 55 thru 53, 55 thru 73, 88, 132	0683-4725	RESISTOR, fxd, comp, 4700 ohms, 5%, 1/4W	01121	CB 4725
R9	0683-1215	RESISTOR, fxd, comp, 120 ohms, 5%, 1/4W	01121	CB 1215
R15, 26, 27, 74 thru 83, 89 thru 93, 96, 99, 102, 105, 108, 109, 110, 115, 122, 123, 125, 129, 130	0683-1515	RESISTOR, fxd, comp, 150 ohms, 5%, 1/4W	01121	CB 1515
R21	0683 1035	RESISTOR, fxd, comp, 10k, 5%, 1/4W	01121	CB1035
R45, 60		UNASSIGNED		
S1, 2, 4, 5, 7, 11 thru 27	3101-1219	SWITCH, toggle, spdt, subminiature	09353	7101 PC
S3	3100-3036	SWITCH, 1-pole, 3-position		
S6, 9, 10	3101-0858	SWITCH, momentary		
S8	3100-3035	SWITCH, 2-pole, 4-position		
U16, 17, 34, 42	1820-0618	INTEGRATED CIRCUIT, TTL	01295	SN23351
U18, 27, 38, 44	1820-0274	INTEGRATED CIRCUIT, DTL	28480	1820-0274
U21, 63, 74	1820-0174	INTEGRATED CIRCUIT, TTL	01295	SN8199
U22, 23, 24, 25, 62	1820-0621	INTEGRATED CIRCUIT, TTL	01295	SN23354
U26, 46	1820-0233	INTEGRATED CIRCUIT, TTL	01295	SN10625
U32, 52	1820-0577	INTEGRATED CIRCUIT, TTL	01295	SN22729
U33, 45, 53, 75, 76, 98	1820-0239	INTEGRATED CIRCUIT, TTL	28480	1820-0239
U35	1820-0070	INTEGRATED CIRCUIT, TTL	01295	SN4345
U43, 65, 92	1820-0537	INTEGRATED CIRCUIT, TTL	28480	1820-0537
U54, 55, 64, 85, 95, 97	1820-0064	INTEGRATED CIRCUIT, TTL	01295	SN4342
U86, 96	1820-0077	INTEGRATED CIRCUIT, TTL	01295	SN4354
U93	1820-0099	INTEGRATED CIRCUIT, TTL	01295	SN4461
U94	1820-0207	INTEGRATED CIRCUIT, TTL	28480	1820-0207

*1219 series and higher.

Table 5-2. Indicator PCA A2 Replaceable Parts

REFERENCE DESIGNATION	HP PART NO.	DESCRIPTION	MFR CODE	MFR PART NO.
CR1, 2, 5 thru 32 TP1 thru 7	1990-0310	DIODE, visible light emitter	28450	1990-0310
	0340-0095	TERMINAL, feedthru teflon insulated	98291	FT-310 P-20
	3050-0023	WASHER, fiber, 1/4 OD	28480	3050-0023

Table 5-3. Oscillator PCA A3 Replaceable Parts

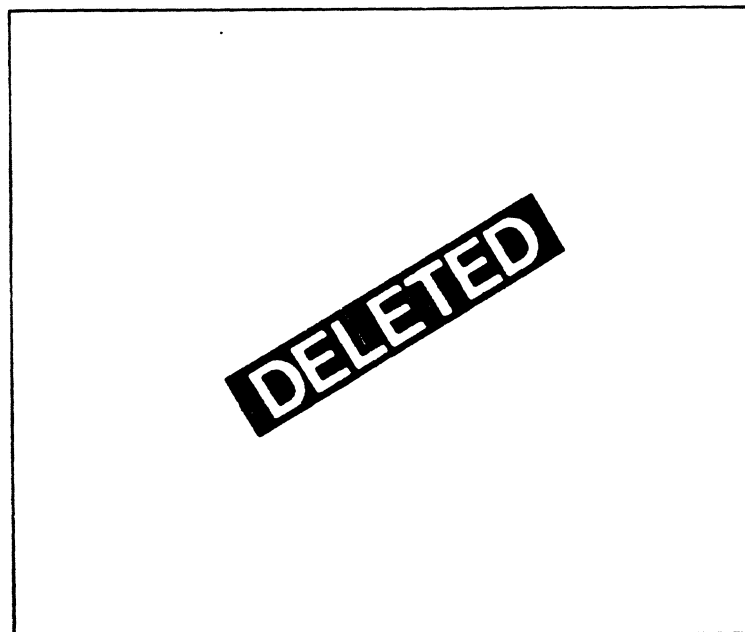

13219-13A

Figure 5-2. Oscillator PCA A3 Parts Location Diagram

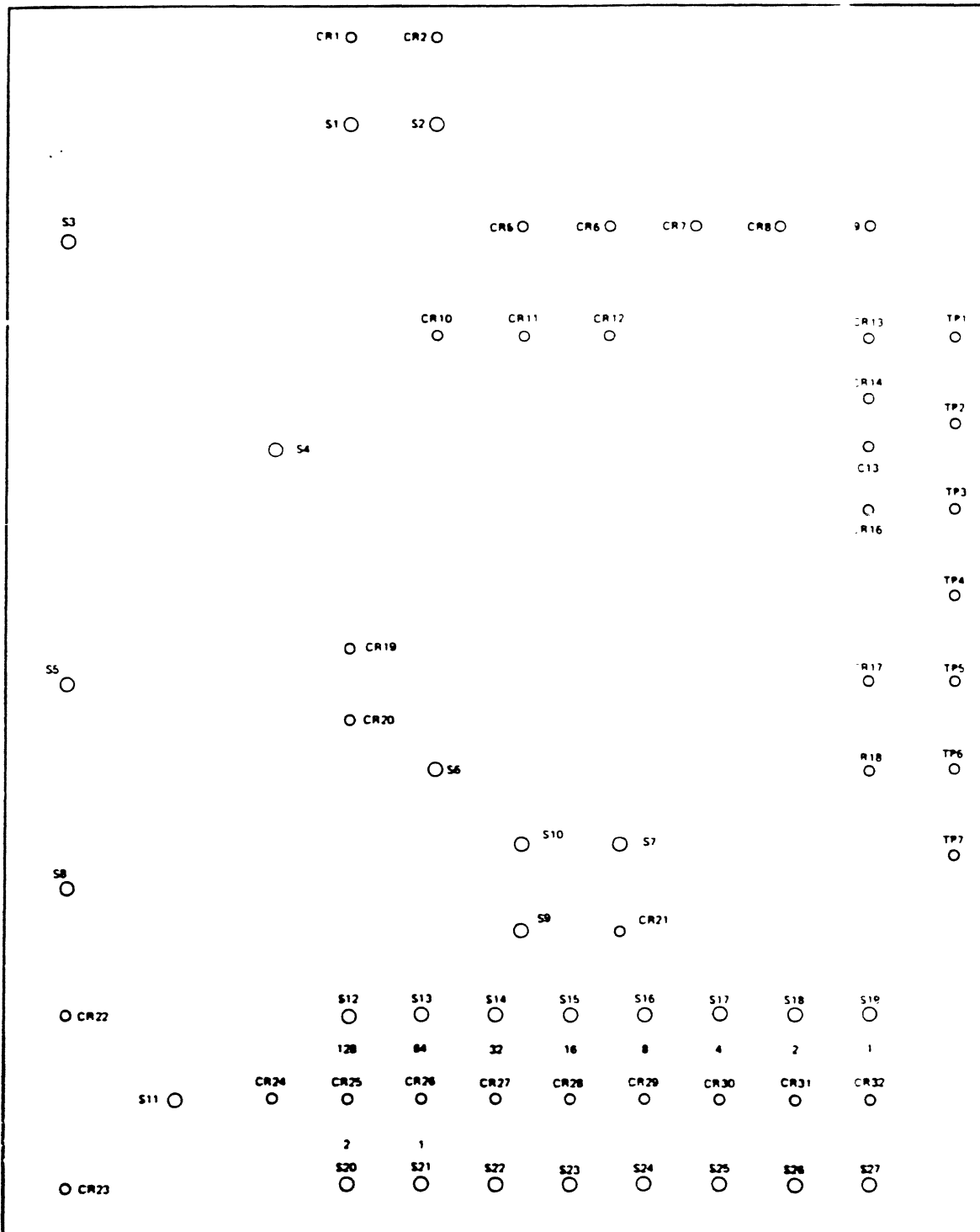

13219-7

Figure 5-3. Indicator PCA A2 Parts Location Diagram

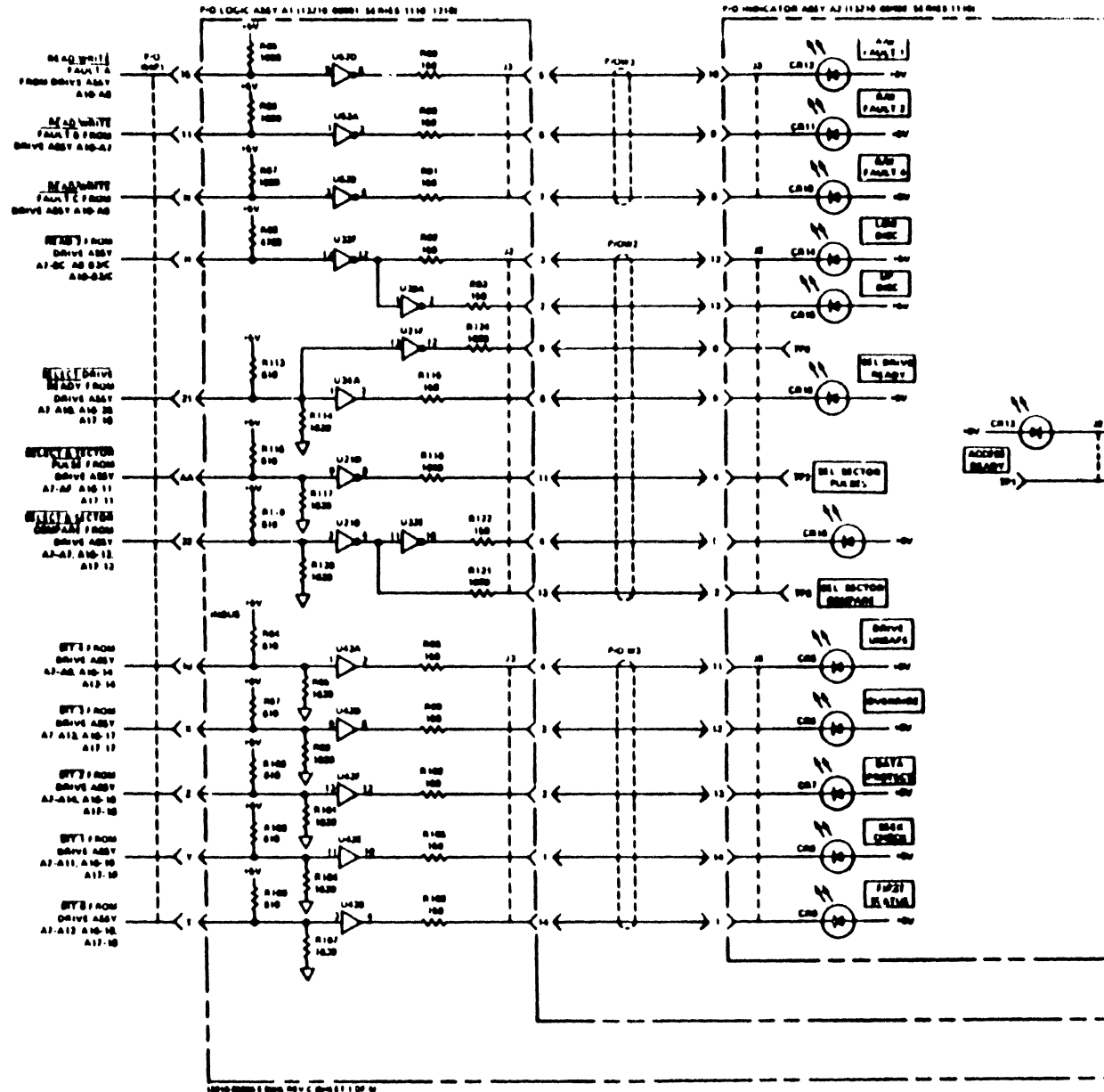

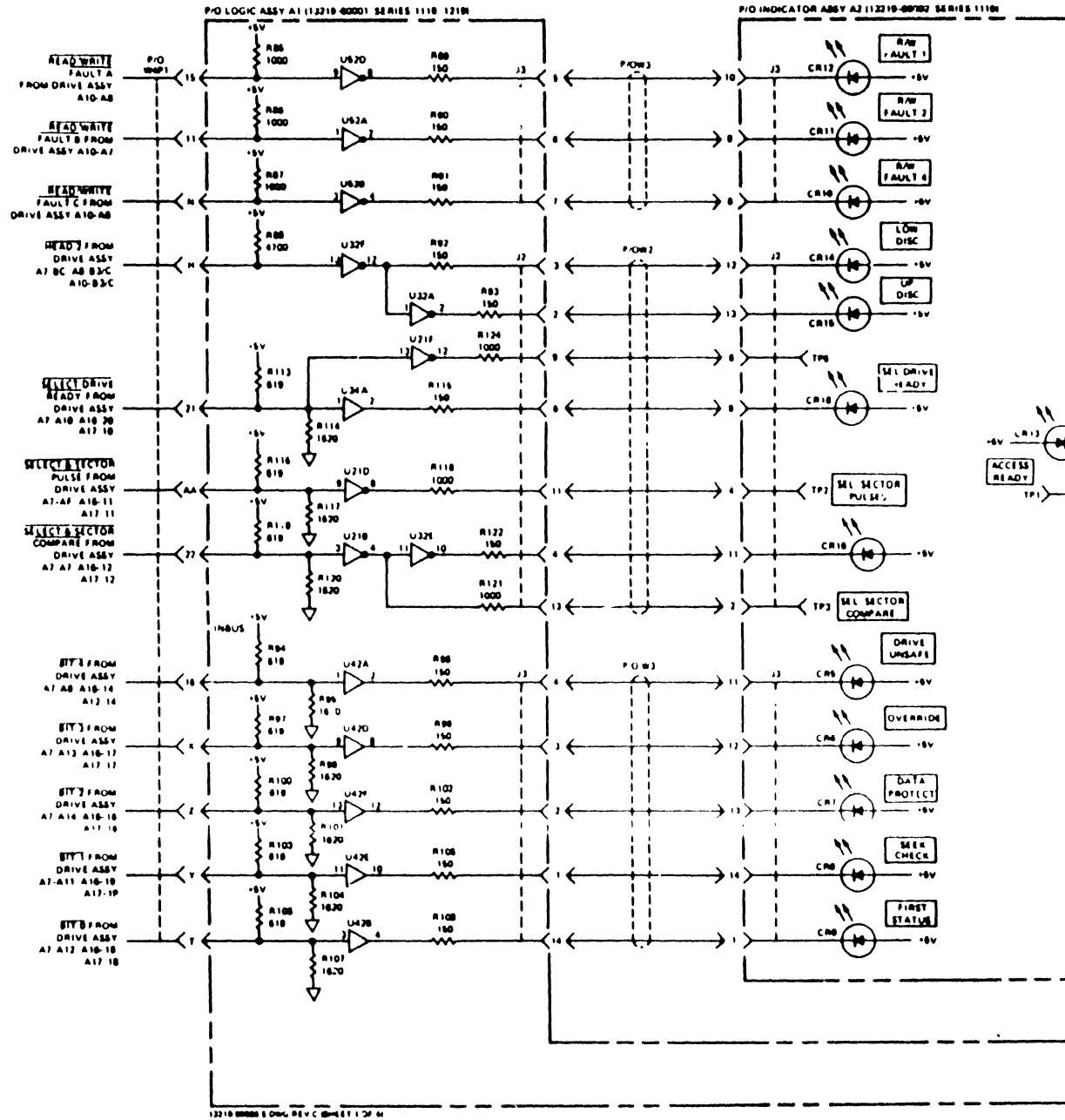

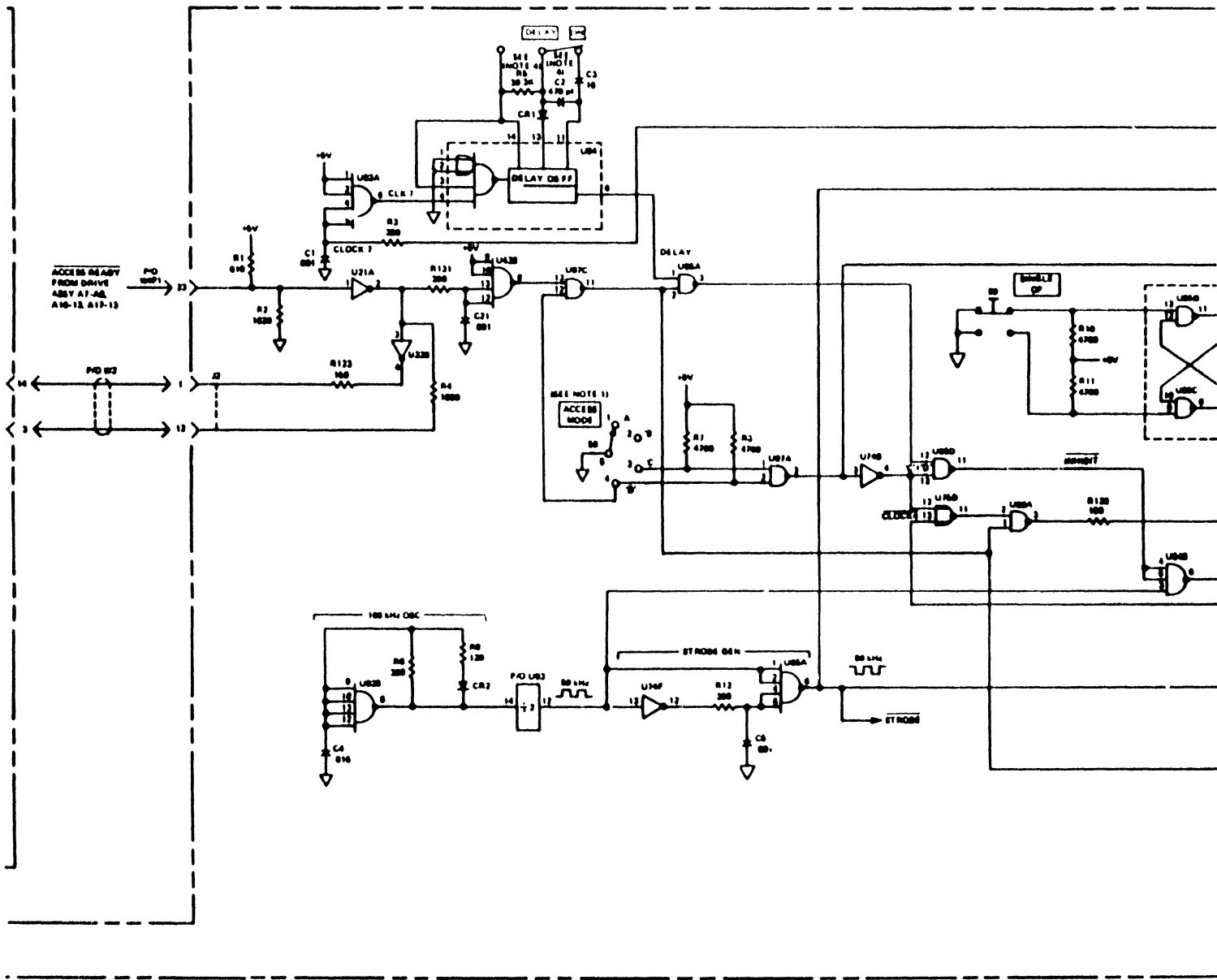

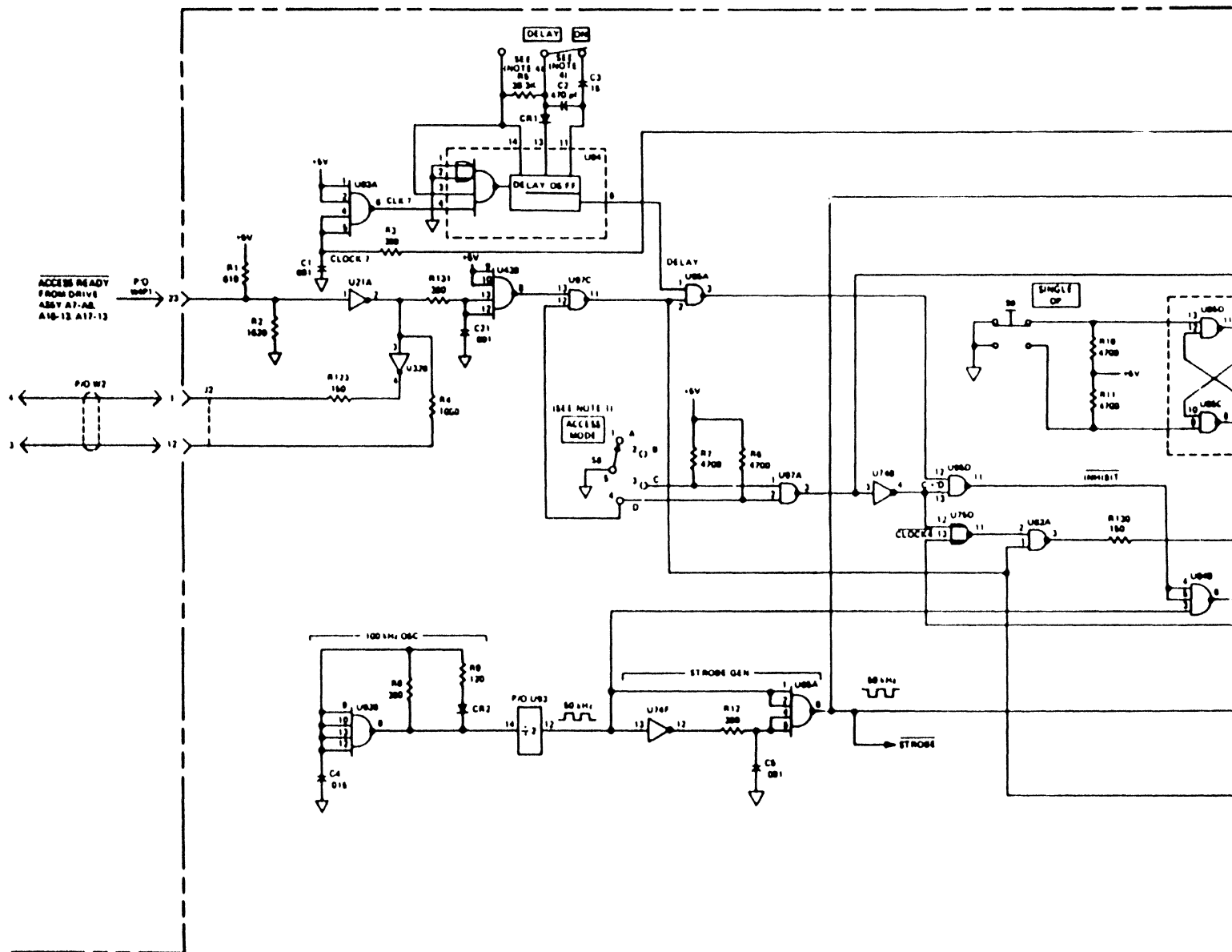

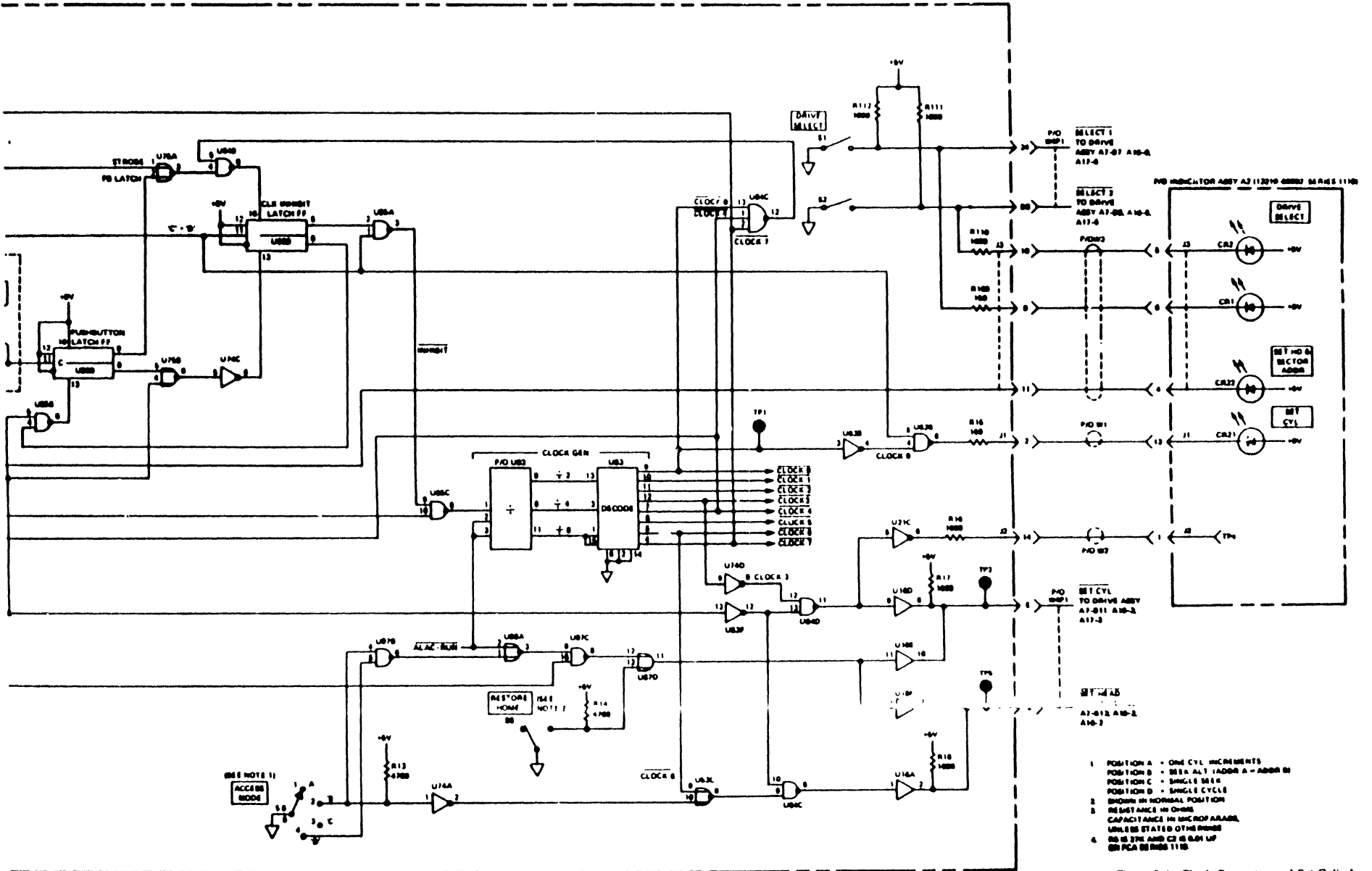
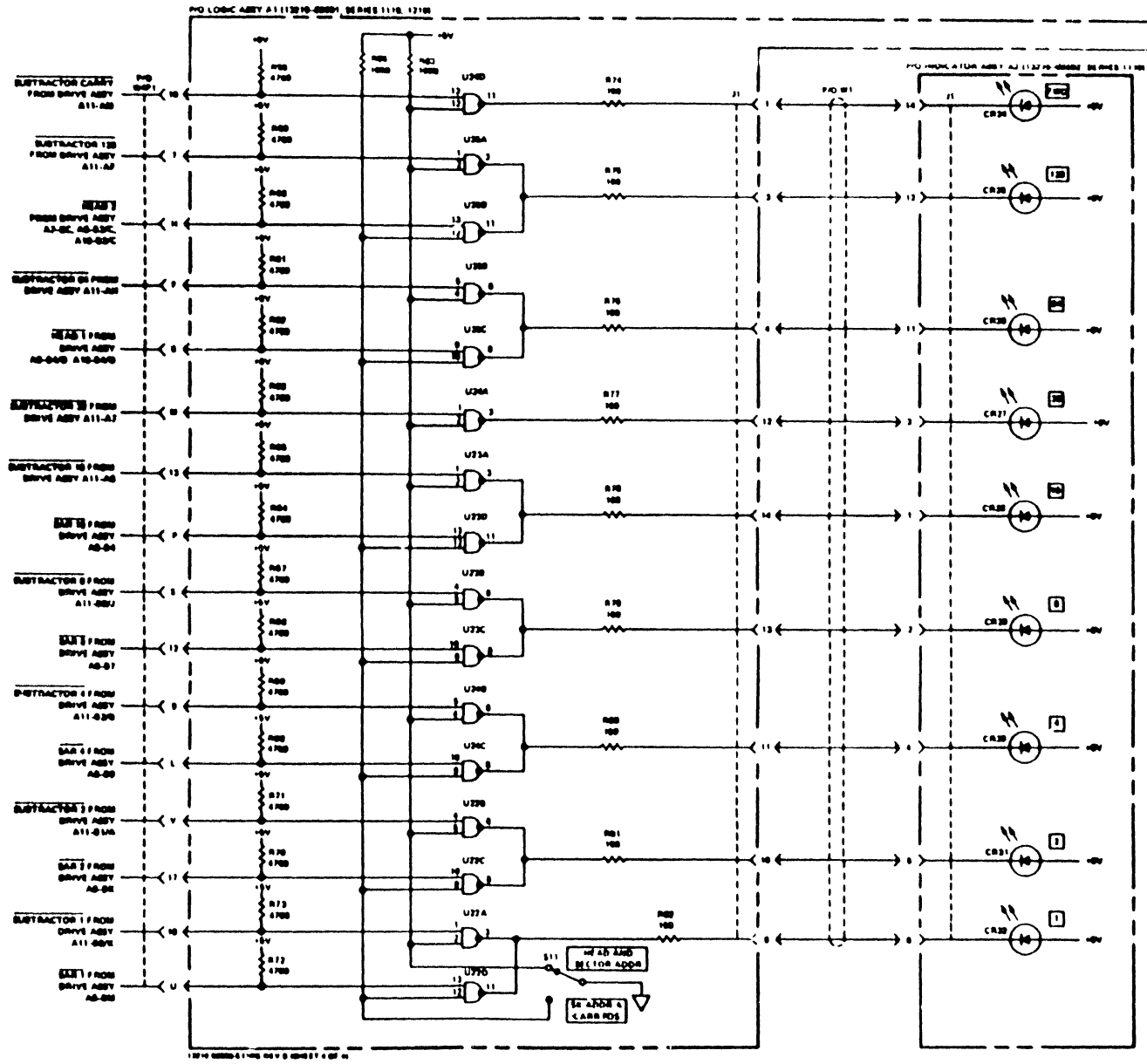
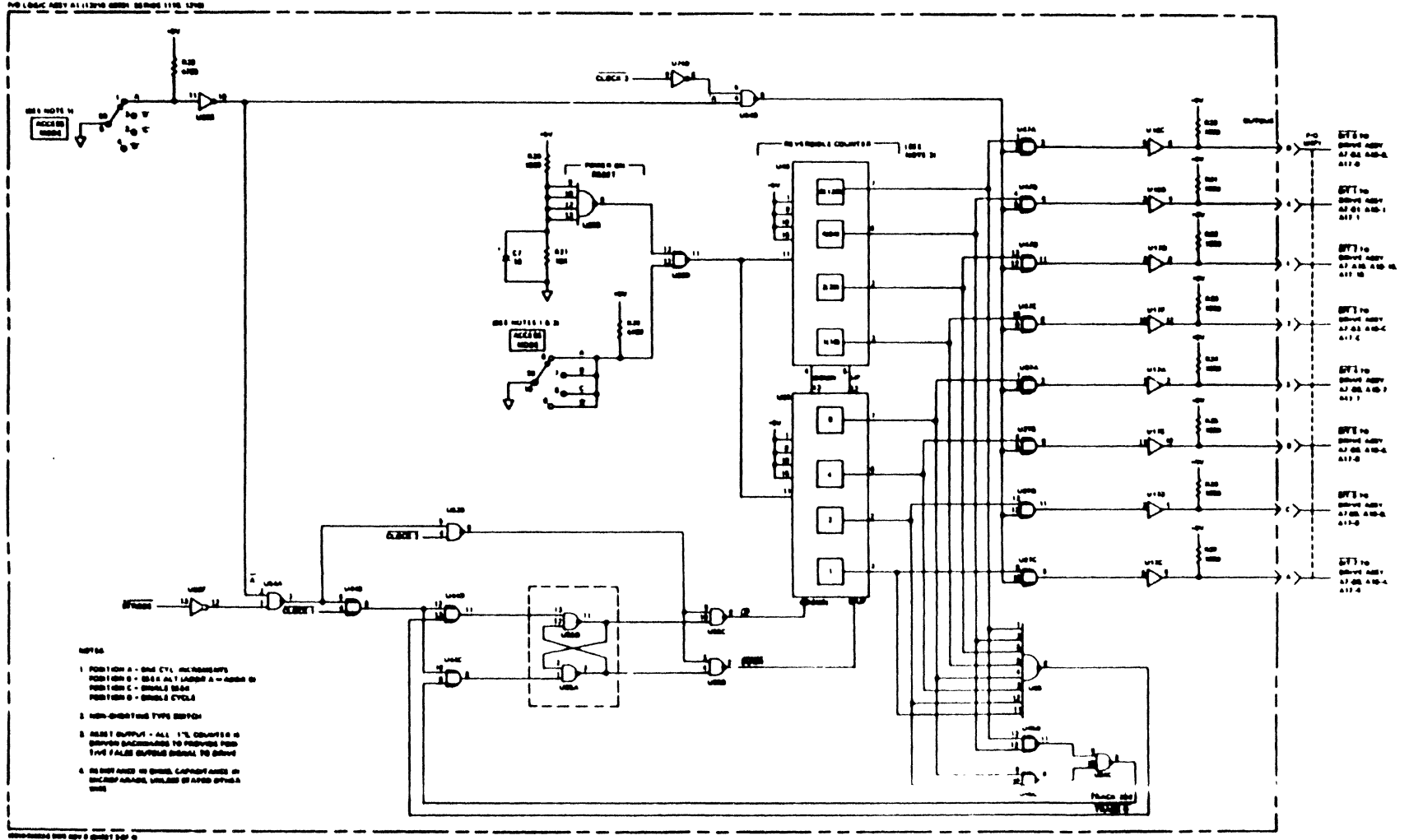

Figure 5-4. Clock Generator and Set Cylinder Circuits, Schematic Diagram





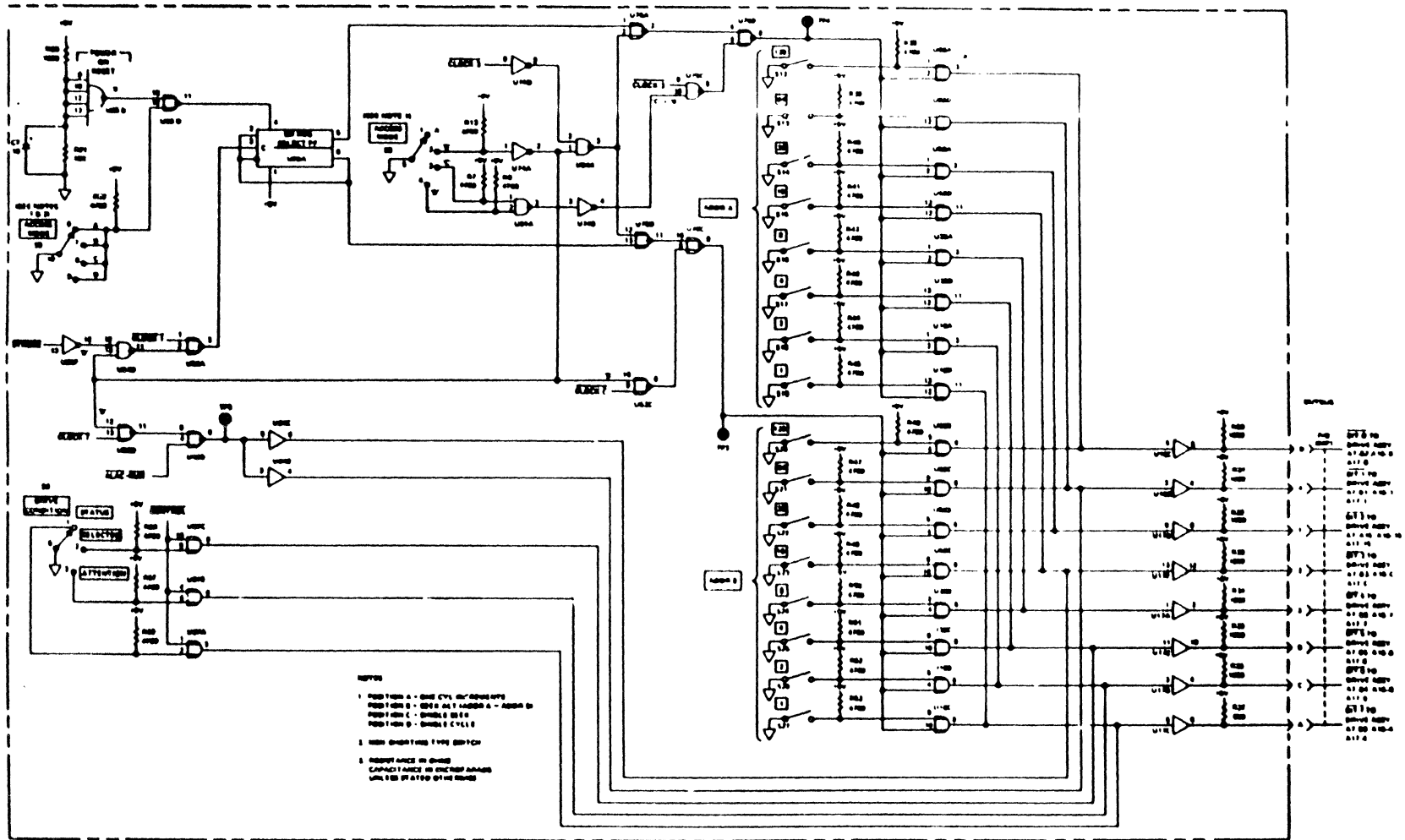

Figure 5-7 Address and Drive Condition Circuits, Schematic Diagram

SECTION VI REPLACEABLE PARTS

6-1. INTRODUCTION.

6-2. This section contains information for ordering replacement parts for the service unit. Separate parts lists and parts location diagrams are provided for each printed circuit assembly in section V of this manual. Parts are listed in these tables in alphanumeric order by reference designation. Table 6-1 is a complete parts list for the service unit.

6-3. Table 6-1 lists the following information for each part:

- a. Hewlett-Packard part number.

Note

When "Com1" appears in the HP PART NO. column for a particular part, that part should be available from normal commercial sources.

- b. Description of the part. (Refer to table 6-2 for an explanation of abbreviations used in the DESCRIPTION column.)

- c. Typical manufacturer of the part as a five-digit code. (Refer to table 6-3 for a listing of the manufacturers that correspond to the codes.)

- d. Manufacturer's part number.

6-4. Items in the DESCRIPTION column of the replaceable parts lists are indented to indicate item relationships, as follows:

DESCRIPTION

MAJOR ASSEMBLY

- * Subassembly
- * Attaching Parts for Subassembly
- ** Subassembly Parts
- ** Attaching Parts for Subassembly Parts

6-5. ORDERING INFORMATION.

6-6. To order replacement parts, address order or inquiry to the local Hewlett-Packard Field Office. (Refer to list at the end of this manual for addresses.) Specify the following information for each part ordered:

- a. Unit model and serial number.
- b. Hewlett-Packard stock number for each part
- c. Description of each part.
- d. Circuit reference designation (if applicable).

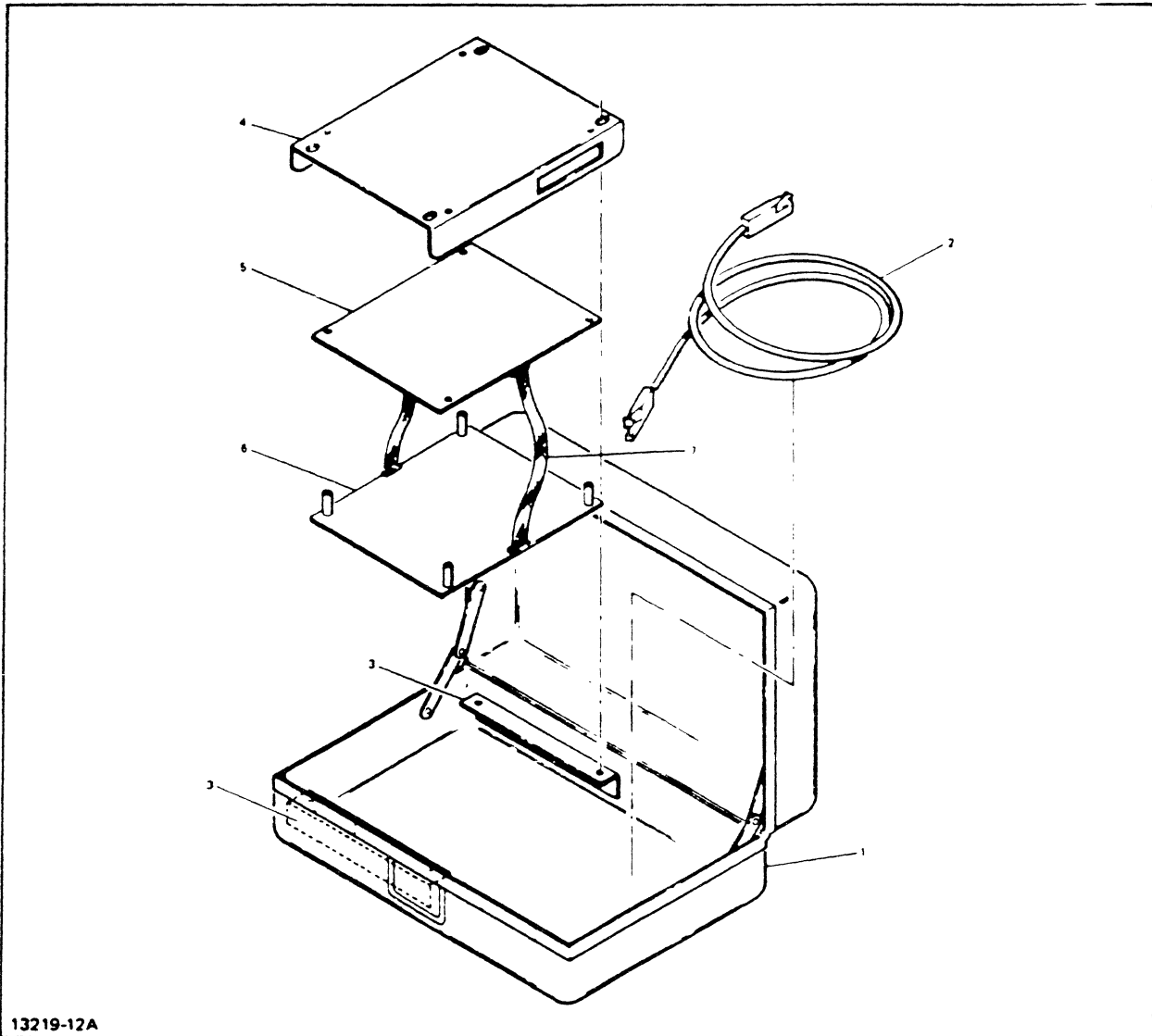

13219-12A

Figure 6-1. HP 13219A Disc Service Unit Parts Location Diagram

Table 6-1. HP 13219A Disc Service Unit Replaceable Parts

FIGURE & INDEX NO.	HP PART NO.	DESCRIPTION	MFR CODE	MFR PART NO.
6-1-1	13219-60004	*CASE, carrying	28480	13219-60004
-2	13219-60003	*DSU CABLE	28480	13219-60003
-3	13219-00002	*BRACKET, panel	28480	13219-00002
-4	13219-00001	*PANEL, front (Attaching Parts)	28480	13219-00001
	Com1	*SCREW, ph. no. 8-32, 0.375 in		
	Com1	*WASHER, flat, no. 8		
		----- X -----		
	13219-60009	*PCA AND CABLE ASSY	28480	13219-60009
-5	13219-60002	**INDICATOR PCA	28480	13219-60002
-6	13219-60001	**LOGIC PCA (Attaching Parts)	28480	13219-60001
	Com1	**SCREW, ph. no. 6-32, 1.0 in		
	Com1	**NUT, assembled washer, no. 6-32		
-7	13219-60005	**CABLE ASSY	28480	13219-60005

Table 6-2. Reference Designations and Abbreviations

REFERENCE DESIGNATIONS		
A = assembly	K = relay	TB = terminal board
B = motor synchro	L = inductor	TP = test point
BT = battery	M = meter	U = integrated circuit, non repairable assembly
C = capacitor	P = plug connector	V = vacuum tube, photocell, etc
CB = circuit breaker	Q = semiconductor device other than diode or microcircuit	VR = voltage regulator
CR = diode	R = resistor	W = cable jumper
DL = delay line	RT = thermistor	X = socket
DS = indicator	S = switch	Y = crystal
E = Misc electrical parts	T = transformer	Z = tuned cavity, network
F = fuse		
FL = filter		
J = receptacle connector		
ABBREVIATIONS		
A = amperes	gr = gray	PCA = printed-circuit assembly
ac = alternating current	grn = green	PWB = printed-wiring board
ad = anode	H = henries	ph = Phillips head
Al = aluminum	Hg = mercury	pk = peak
AR = as required	hr = hour(s)	p-p = peak-to-peak
adj = adjust	Hz = hertz	pt = point
assy = assembly	hdw = hardware	PIV = peak inverse voltage
B = base	hex = hexagon, hexagonal	PNP = positive-negative-positive
bp = bandpass	ID = inside diameter	PWV = peak working voltage
bp_i = bits per inch	IF = intermediate frequency	porc = porcelain
blk = black	in = inch, inches	posn = position(s)
blu = blue	I/O = input/output	pozi = pozidrive
brn = brown	int = internal	rf = radio frequency
brs = brass	incl = include(s)	rdh = round head
Btu = British thermal unit	insul = insulation, insulated	rmo = rack mount only
Be Cu = beryllium copper	impgrg = impregnated	rms = root mean square
C = collector	incand = incandescent	RWV = reverse working voltage
cw = clockwise	ips = inches per second	rect = rectifier
ccw = counterclockwise	k = kilo (10 ³), kilohm	r/min = revolutions per minute
cer = ceramic	lp = low pass	RTL = resistor transistor logic
cmo = cabinet mount only	m = milli (10 ⁻³)	s = second
com = common	M = mega (10 ⁶), megohm	SB, TT = slow blow
crt = cathode ray tube	Myl = Mylar	Se = selenium
CTL = complementary transistor logic	mfr = manufacturer	Si = silicon
cath = cathode	mom = momentary	scr = silicon controlled rectifier
cd pl = cadmium plate	mtg = mounting	sil = silver
comp = composition	misc = miscellaneous	st = stainless steel
conn = connector	Met Ox = metal oxide	stl = steel
compl = complete	mintr = miniature	spcl = special
dc = direct current	n = nano (10 ⁻⁹)	spdt = single pole double throw
dr = drive	n c = normally closed or no connection	spt = single pole single throw
DTL = diode transistor logic	Ne = neon	semicond = semiconductor
depc = deposited carbon	no = number	Ta = tantalum
dpdt = double pole double throw	n o = normally open	td = time delay
dpst = double pole single throw	np = nickel plated	Ti = titanium
E = emitter	NPN = negative positive negative	tgl = toggle
ECL = emitter-coupled logic	NPO = negative positive zero (zero temperature coefficient)	thd = thread
ext = external	NSR = not separately replaceable	tol = tolerance
encap = encapsulated	NRFR = not recommended for field replacement	TTL = transistor transistor logic
electh = electrolytic	OD = outside diameter	U(μ) = micro (10 ⁻⁶)
F = farads	OBD = order by description	V = volt(s)
FF = flip-flop	orn = orange	var = variable
flh = flat head	ovh = oval head	vio = violet
Film = film	oxd = oxide	VDCW = direct current working volts
Fixd = fixed	p = pico (10 ⁻¹²)	W = watts
flth = filister head	PC = printed circuit	ww = wirewound
G = giga (10 ⁹)		wht = white
Ge = germanium		WIV = working inverse voltage
gl = glass		yel = yellow
grd = grounded		

Table 6-3. Code List of Manufacturers

CODE NO.	MANUFACTURER	ADDRESS
01121	Allen Bradley Co.	Milwaukee, Wisconsin
01295	Texas Instruments, Inc., Semiconductor Components Div	Dallas, Texas
07263	Fairchild Camera & Inst. Corp., Semiconductor Div	Mountain View, California
08353	C & K Components, Inc.	Newton, Massachusetts
12040	National Semiconductor Corp.	Danbury, Connecticut
28480	Hewlett-Packard Company	Palo Alto, California
81640	Controls Company of America, Control Switch Division	Folcroft, Pennsylvania