

## P-200CT Power Supply

The P-200 Power supply is a fixed voltage power supply designed to be used with several SWTPC kits. The P-200CT version is supplied with those parts required to power the CT-64 Terminal system and the CT-VM video monitor. The P-200CT provides the following outputs:

+12 VDC  $\pm$  5% @ 1.5 amps  
+ 5 VDC  $\pm$  5% @ 3.0 amps  
- 3 VDC  $\pm$  5% @ 0.1 ma.  
-12 VDC  $\pm$  5% @ 0.1 amps  
12 VAC  $\pm$ 20% @ 10 ma.

The power supply consists of the 3 1/8" W X 3 3/8" L X 3 3/4" H power transformer, two large 2" diameter filter capacitors, 3 1/4" W X 4" L circuit board, two regulator transistors and a 4 1/8" W X 3" H two transistor heatsink. The design utilizes integrated regulators for adjustment free outputs and built-in overload protection. The power supply may be operated from 120 or 240 VAC, 50 to 60 Hz power systems.

### PC Board Construction

- ( ) Clean the copper foil side of the circuit board with a piece of Scotchbrite<sup>R</sup> (available at most hardware stores) to remove any oxidation.
- ( ) Attach all of the resistors to the circuit board. Use the parts list and the component layout drawing to locate the proper position for each part. As with all components unless otherwise noted, mount each flush with the top of the board, bend the leads parallel to the board on the foil side and trim so that 1/16" to 1/8" of wire remains. Solder.
- ( ) Attach all of the diodes to the circuit board. Be sure the banded end of each diode matches with the outline shown in the component layout drawing. Solder.
- ( ) Install electrolytic capacitors C1 and C2 on the circuit board. Be sure to orient these components so their polarity matches with that shown in the component layout drawing. Solder.
- ( ) Using a pair of wire cutters, cut the center lead off of regulator transistor Q1. Secure the transistor to the circuit board using a

#4-40 X 1/4" screw, lockwasher and nut. The transistor must be oriented as shown in the component layout drawing and attached so the metal face is flat against the circuit board. Solder.

- ( ) Using some #18 gauge buss wire install jumpers in the two locations indicated with the number "12". Solder. Make sure NO jumper is installed in the "24" position. Use the component layout drawing for reference.
- ( ) Attach the twelve pin Wafercon connector to the circuit board. Be sure to orient the connector as shown in the component layout drawing. Solder.
- ( ) Complete the first half of steps 1 thru 13 of the wiring table. Cut each wire to the specified length and attach and solder it to the specified point on the circuit board from the top side. Do not connect the other ends of the wires to their destination terminations yet.
- ( ) This completes the circuit board assembly. Check to make sure that all connections have been soldered and that there are no cold solder joints. Also make sure that all components have been installed correctly as called for in the instructions. Take note that there are many power supply components not used in the P-200CT version of the kit. Install only those components listed in the parts list.

#### Attaching the Connector to the Power Transformer

Leave all of the power transformer secondary leads full length and trim each of the exposed wires so that only 1/8" protrudes beyond the insulation. Attach and solder the specified connector pins to each of the leads using the table below for reference. Use the connector reference sheet contained within this instruction set if you have any problem distinguishing between the connector pins. Do NOT insert the connector pins into the connector shell until told to do so later in the instructions.

<u>Transformer Secondary Wire</u>	<u>Connector pin Gender</u>	<u>Connector Pin #</u>
yellow	female	1
green-white	female	2
green-yellow	male	3
green	female	4
blue-white	male	7
brown	female	9
blue	female	10
blue	female	11
brown	male	12

- ( ) Take note that the back side of the male connector shell is numbered. Using the previous table, carefully insert each of the specified connector pins into the correct numerical position of the connector shell. Insert the pins from the back or numbered side of the connector and be careful not to make a mistake. The pins cannot be removed without destroying them once they have been pressed into place. This completes the transformer connector assembly.

#### Power Supply onto chassis assembly

- ( ) Attach the two transistor heatsink to the chassis using four #6-32 X 3/8" screws, lockwashers and nuts. Position the heatsink very carefully so the holes in the heatsink align with those punched in the chassis. Put a ground lug under the lower left hand mounting nut as shown in the chassis pictorial.
- ( ) Snap the four nylon printed circuit board mounts onto the chassis in the positions corresponding to the mounting holes on the circuit board.
- ( ) Attach the clamps for electrolytic capacitors C3 and C4 to the chassis using #6-32 X 1/4" screws, lockwashers and nuts. Orient the clamps as shown in the chassis pictorial. Leave the mounting screws loose until the capacitors have been installed as called for later in the instructions.
- ( ) Attach lug strip LS-1 to the chassis using a #6-32 X 1/4" screw, lockwasher and nut. Orient the lug strip as shown in the chassis pictorial.
- ( ) Attach fuseholder F1 to the chassis. Orient the fuseholder as shown in the chassis pictorial.
- ( ) Using a pair of pliers crimp the strain relief onto the line cord at a point about 3" from the end of the line cord and insert the compressed strain relief and line cord assembly into the 1/2" hole provided on the rear of the chassis from the outside of the chassis, then release.
- ( ) Now insert electrolytic capacitors C3 and C4 into their clamps. Use the parts list and chassis pictorial to determine position and orientation. Install them exactly as shown in the pictorial. These capacitors are polarized so the + terminal must be positioned as shown in the drawings. Secure the capacitors with #6-32 X 1/2" screws, lockwashers and nuts.
- ( ) Tighten all of the capacitor clamp mounting screws.
- ( ) Using #10-32 X 1/4" screws attach two terminal lugs to the (+) terminal and five terminal lugs to the (-) terminal of capacitor C3. Also attach two terminal lugs to the (+) terminal and five terminal lugs to the (-) terminal of capacitor C4. Use the chassis pictorial to show proper orientation.
- ( ) Orient the power transformer so the four wire primary side is nearer the rear of the chassis and secure with four #8-32 X 3/8" screws, flatwashers and nuts.

- ( ) Remove the precoated insulators from their packages and place over the pins on the bottom of regulator transistors Q3 and Q4.
- ( ) Install transistors Q3 and Q4 onto the heatsink from the outside of the chassis. Be sure you have put the right transistor in the right set of holes. Secure each transistor with #6-32 X 1/2" screws, insulated shoulder washers, ground lugs and nuts. NOTE: The case of each power transistor is electrically a transistor junction and hence must be electrically isolated from all other electrical junctions including the chassis. The mounting screws are electrically connected to each transistor case and you must be sure the screws do not contact either the heatsinks or chassis as they pass through the assembly. If you are careful to line up the mounting holes in the heatsink and the chassis before securing the transistor mounting screws there should be no problem. Keep in mind also that the wire leads of each power transistor must be centered in the large holes through which they pass. The mounting screws must be tightened evenly and with enough pressure to slightly compress the transistor insulators. The entire bottom of the transistor case must be in solid contact with the insulator for good heat transfer.
- ( ) Orient the printed circuit board as shown in the chassis pictorial and snap it onto its mounts.
- ( ) For American standard 120 VAC line operation complete steps 14 thru 17 of the wiring table. For European standard 240 VAC operation complete steps 18 thru 20 of the wiring table. In step 19 of the wiring table it will be necessary to use some electrical tape to insulate the connection between the two transformer wires.
- ( ) Now go back and complete the second half of wiring steps 1 thru 13. When attaching the wires to the regulator transistors Q3 and Q4, slip a 1" piece of heat shrinkable tubing over each of the wires to be attached first. Solder the wire directly to the transistor pin, slip the heat shrinkable tubing over the exposed connection and shrink the tubing with the heat from your soldering iron. When making connections to J11 connector pins (supplied with the CT-64 main board kit of parts) use the connector reference sheet contained within this instruction set if you have any problem distinguishing between the connector pins. Do NOT insert the connector pins into the connector shell until told to do so later in the instructions.
- ( ) Complete wiring steps 21 thru 34 of the wiring table. Steps 23 and 24 are in reference to an optional power switch (not supplied with the kit) which may be installed on the cover, rear panel or omitted entirely. If you omit the switch, attach and solder a #18 piece of wire between F1 terminal B and LS-1 terminal A in place of wiring steps 23 and 24. References to N2 in steps 27 and 33 of the wiring table apply to a six pin male connector shell and its pins (supplied with the kit). This connector and its mate are supplied with the power supply kit to provide power for the optional CT-VM video monitor which is powered by the CT-200CT. Wiring steps 29 and 30 are in reference to the same male connector pin. Two parallel wires are necessary to reduce power supply ground noise.

- ( ) Now go back insert the specified connector pins into male connector shell J11 (supplied with the CT-64 main board kit of parts). Take note that the back side of the connector shell is numbered. Using the following table insert each of the specified connector pins from the back or numbered side of the connector and be careful not to make a mistake. The pins cannot be removed without destroying them once they have been pressed into place.

<u>Wiring Table Step #</u>	<u>Connector Pin Gender</u>	<u>Connector Pin #</u>
5	male	5
10	female	1
11	female	4
12	female	2
29 & 30	male	3
32	female	6

- ( ) Insert the specified connector pins with attached wires of wiring steps 27 and 33 into the six pin male connector shell N2 supplied with the P-200CT kit. Follow the installation precautions given in the preceding step. The assembly procedure for the mating connector shell is supplied with the CT-VM instructions.
- ( ) Go back and double check all wiring steps and solder connections for correctness and completion. Even a simple mistake can cause costly damage to your power supply.
- ( ) Plug the twelve pin male connector attached to the power transformer's secondary leads onto the twelve pin receptacle on the power supply printed circuit board. Be sure to orient the connector correctly. It will fit only one way.
- ( ) Install fuse F1 into the fuseholder.
- ( ) Without having anything plugged onto power connectors J11 or N2 and after making sure these connectors are not inadvertently touching anything they shouldn't be, plug the line cord into a wall outlet and turn the power switch ON.
- ( ) Using the metal chassis as a ground reference measure the following voltages on the two power connectors listed below. If you find that any of the voltages do not measure as specified, immediately remove power and recheck all wiring and solder connections. The voltage measurement on the -3 line may read a little low if you are not testing with a high impedance voltmeter so do not get alarmed.

Six Pin Male Connector J11

<u>Pin #</u>	<u>Voltage</u>	<u>Tolerance</u>
1	-12 VDC	+5%
2	+ 5 VDC	+5%
3	0 VDC	+5%
4	- 3 VDC	+5%
5	12 VAC	+20%
6	+12 VDC	+5%

Six Pin Male Connector N2

<u>Pin #</u>	<u>Voltage</u>	<u>Tolerance</u>
3	0 VDC	+5%
6	+12 VDC	+5%

- ( ) If everything checks out as called for then remove power, unplug the unit and go back to the main terminal instructions for final checkout. Make absolutely sure not to get the two six pin power plugs swapped around when plugging the power connector onto the main terminal board. Once you are convinced that the power supply is working as it should be use the wire ties supplied with the kit to bundle the wires where necessary.

Parts List P-200CT Power Supply

Resistors

— R1 240 ohm 1% resistor  
— R2 2030 ohm 1% resistor  
— R6 723 ohm 1% resistor  
— R7 240 ohm 1% resistor

Diodes

— D1\* 1N5402 high current diode  
— D2\* " " " "  
— D3\* " " " "  
— D4\* " " " "  
— D5\* 1N4003 diode  
— D7\* 1N5402 high current diode  
— D8\* " " " "  
— D9\* " " " "  
— D10\* " " " "  
— D11\* 1N4003 diode  
— D12\* " " " "  
— D13\* " " " "  
— D14\* " " " "

Capacitors

— C1\* 1000 mfd @ 25 VDC electrolytic capacitor  
— C2\* 1 mfd @ 15 VDC tantalum electrolytic capacitor  
— C3\* 20,000 mfd @ 25 VDC electrolytic capacitor  
— C4\* 29,000 mfd @ 15 VDC electrolytic capacitor

Regulators

— Q1\* LM320T-12 -12 VDC regulator  
— Q3\* LM323 +5 VDC regulator  
— Q4\* LM317 adjustable regulator

Misc.

— T1\* Power transformer 50-60 Hz  
Primary: 120/240 VAC  
Secondaries: 12 VAC @ 1.5 amp  
12 VAC @ 1.5 amp  
7 VAC @ 3 amp  
24 VAC @ 200 ma  
— F1 2 1/2 amp slo-blo fuse

All components flagged with a (\*) must be oriented as shown in the component layout drawing and pictorials.

Connector Reference Sheet

In order to avoid confusion in distinguishing between the various connectors supplied with our many kits, we are including this connector reference sheet with the kit instruction set. We have had a great many customers interchange the male and female connector shells when assembling their kits so we have clearly illustrated each connector along with its proper name and gender on this reference sheet. All are shown actual size.



Male Pin

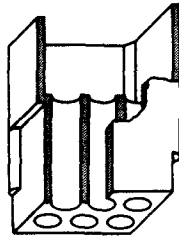

Molex Female Shell Connector

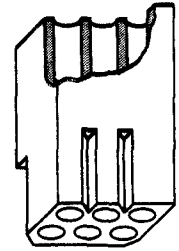

Molex Male Shell Connector



Female Pin



Pin for Harness Connector

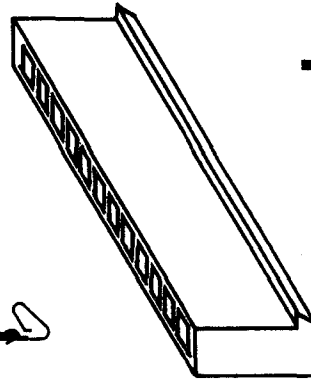

Harness Connector

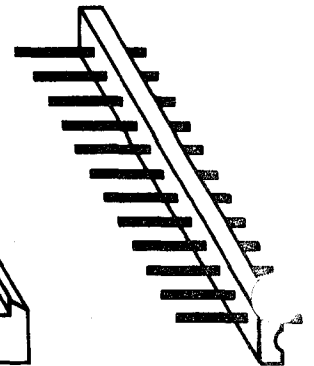

Straight Pin Edge Connector



Molex Wafercon<sup>®</sup>

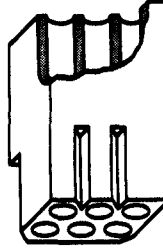

Molex Male Shell Connector



Male Solder Tail Pin  
PC Type



Female Solder Tail Pin  
PC Type



WIRE			FROM			TO		
STEP	LENGTH	GAUGE	PART	TERMINAL	SOLDER	PART	TERMINAL	SOLDER
1	13"	#18	PC board	A	yes	C3 lug	(+)	yes
2	4"	#18	PC board	B	yes	Q4	B4	yes
3	4 1/2"	#18	PC board	C	yes	Q4	B1	yes
4	11"	#18	PC board	F	yes	C4 lug	(+)	yes
5	22"	#18	PC board	B	yes	male pin	J11 #5	yes
6	12"	#18	PC board	G1	yes	C3 lug	(-)	yes
7	5"	#18	PC board	G2	yes	C4 lug	(-)	yes
8	9 1/2"	#18	PC board	G3	yes	C4 lug	(-)	yes
9	6"	#18	PC board	G4	yes	C3 lug	(-)	yes
10	22"	#18	PC board	-12	yes	female pin	J11 #1	yes
11	21"	#18	PC board	-3	yes	female pin	J11 #4	yes
12	22"	#18	PC board	+5	yes	female pin	J11 #2	yes
13	12"	#18	PC board	+5	yes	Q3	A2	yes
120 VAC OPERATION								
14	6"	-	T1	Black	-	LS-1	C	no
15	6"	-	T1	White	-	LS-1	C	no
16	6"	-	T1	Blk-Wht	-	LS-1	A	no
17	6"	-	T1	Blk-Red	-	LS-1	A	no
240 VAC OPERATION								
18	6"	-	T1	Black	-	LS-1	C	no
19	6"	-	T1	white	-	T-1	Blk-Red	yes
20	6"	-	T1	Blk-Wht	-	LS-1	A	no
21	-	-	line cord	A	-	F1	A	yes
22	-	-	line cord	B	-	LS-1	C	yes
23	-	#18	S1 (opt)	A	yes	F1	B	yes
24	-	#18	S1 (opt)	B	yes	LS-1	A	yes
25	8 1/2 "	#18	C3 lug	(-)	yes	C4 lug	(-)	yes
26	8"	#18	C4 lug	(-)	yes	Q3	A4	yes
27	18"	#18	C4 lug	(-)	yes	female pin	N2 #3	yes
28	11 1/2"	#18	C4 lug	(+)	yes	Q3	A1	yes

WIRE			FROM			TO		
STEP	LENGTH	GAUGE	PART	TERMINAL	SOLDER	PART	TERMINAL	SOLDER
29	25"	#18	C3 lug	(-)	no	male pin	J11 #3	no
30	25"	#18	C3 lug	(-)	yes	male pin	J11 #3	yes
31	11"	#18	C3 lug	(+)	yes	Q4	B2	yes
32	26"	#18	Q4	B3	no	female pin	J11 #6	yes
33	18"	#18	Q4	B3	yes	female pin	N2 #6	yes
34	11"	#18	C3	(-)	yes	heatsink	gnd. lug	yes

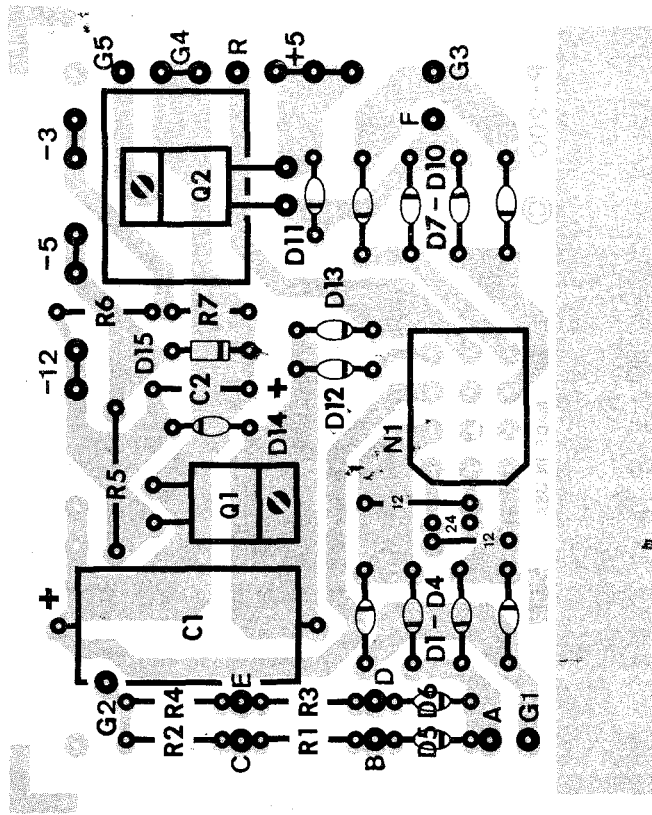

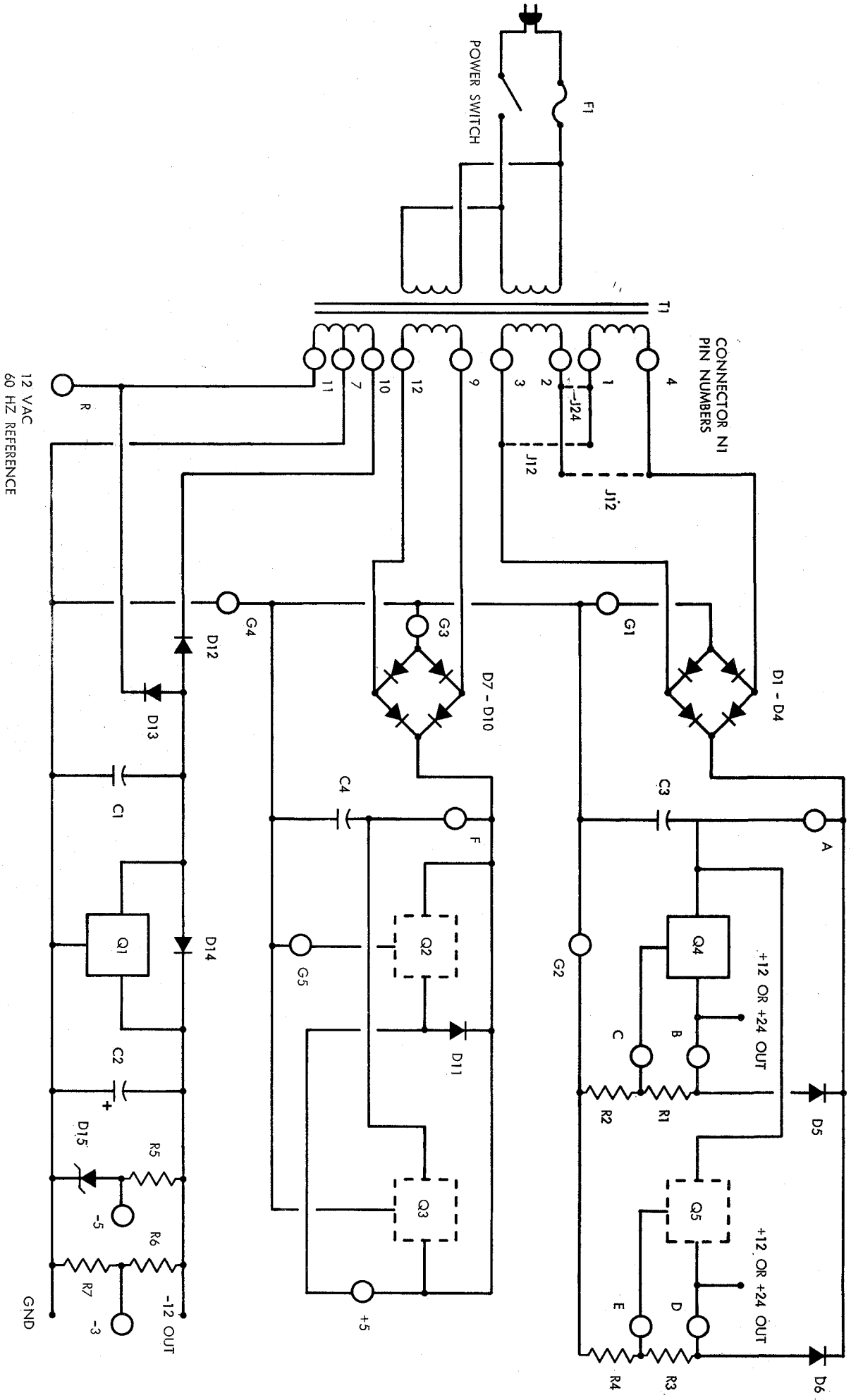

SCHEMATIC P - 200 POWER SUPPLY