

# SCALDsystem I SCALDsystem II

Workstations Supporting  
the SCALD Design Language

Products 4400 Series, 5400 Series

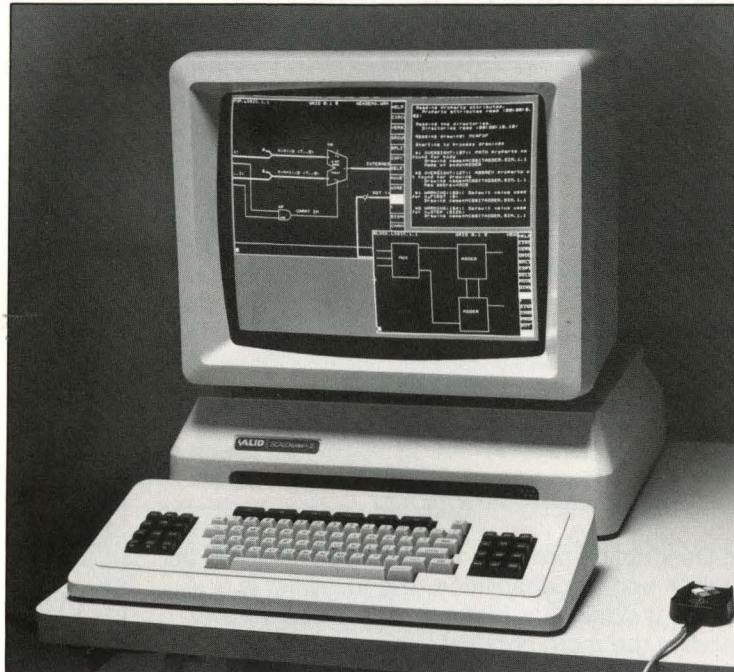

**Features**

- Stand-alone, Cluster, and Network Configurations.
- Supports All SCALD Design Tools, plus much more:
  - Schematic Capture.
  - Timing Verification.
  - Logic Simulation.
  - Physical Design.
  - Test Generation.
  - Fault Simulation.
- Supports analysis tools running locally (no host computer required), and/or on a host system (VAX/VMS™, 370/VM™).
- Supports Realchip™ Modeling System for simulation with complex VLSI devices.
- Supports Realfast™ Simulation System for very high speed simulations of multi-million gate designs.
- The easiest-to-learn full-function CAE system in the industry.

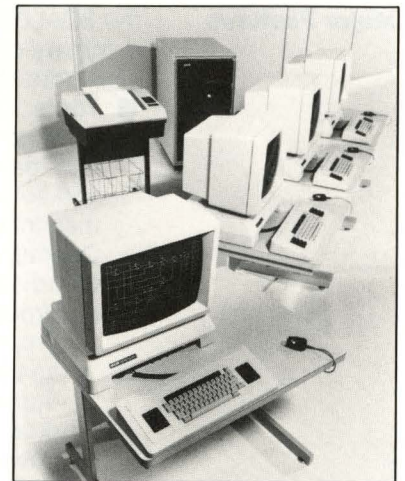

**Overview**

The creation of a design, whether for implementation on a printed circuit board or in a gate array, begins with a concept and ends with a finished product. Bridging the gap between those two ends is the realm of Valid's SCALDsystem™.

The SCALDsystem™ implements Structured Computer-Aided Logic Design: a design methodology, invented by two of Valid's founders, which supports hierarchical and abstract design techniques, and encourages parallel design and validation. In addition, it automates those steps in the design cycle that are time consuming, error prone, and tedious—those very steps that contribute nothing to creativity, but instead rob the designer of his creative time.

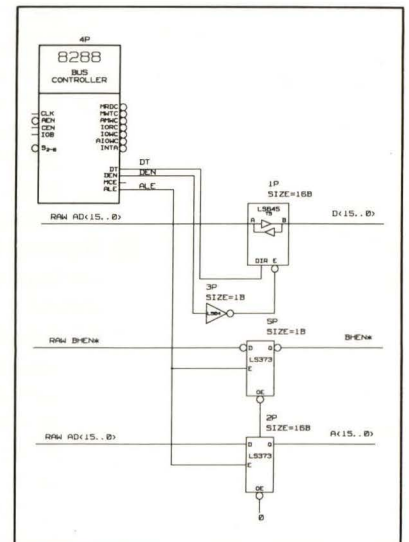



**Overview  
(continued)**

As a result, an electronic circuit designer is much more productive with a SCALDsystem™. He is more productive because he spends more time doing those things for which he was trained: translating concepts into working circuit designs.

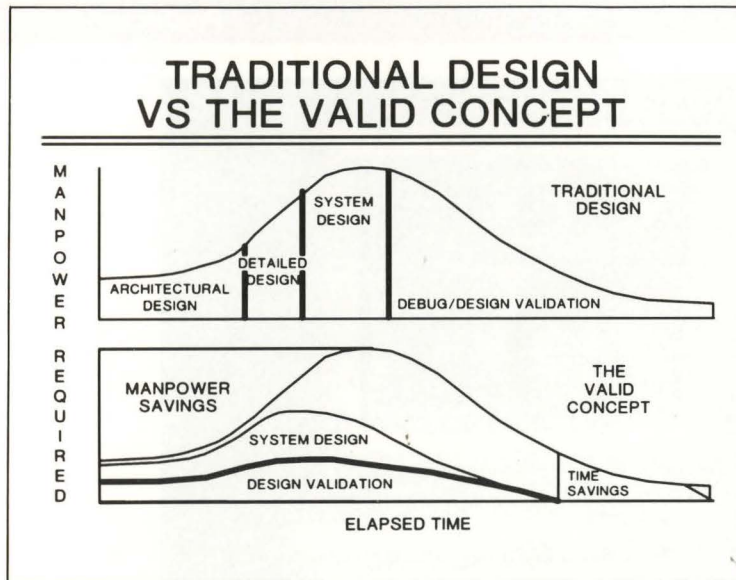
**Summary of  
Major Features**

This Product Description provides a detailed explanation of the SCALDsystem™ and its capabilities. The following is a summary of the most significant features, to provide an overview prior to reading the more detailed information.

- Tools.** CAE design and validation tools demand an optimum balance of hardware and software features. For that reason, Valid designs and produces both the hardware and software in the SCALDsystem™. These CAE tools are then integrated with the equally powerful UNIX™ Operating System and Ethernet™ Local Area Networking to provide design and validation capabilities that are unsurpassed in the CAE industry.
  - Proprietary *computer and workstation* designs ensure an optimum hardware/software balance.
  - Supports the proven *SCALD design language*, plus proprietary extensions and new software tools.
  - Powerful *multiprocessor hardware* ensures high performance: a 68010 central processor for running UNIX™ and the analysis tools, plus a dedicated Intel 8086 graphics engine supporting each workstation for high speed graphics entry and processing.
  - The industry-standard *UNIX™ Operating System* ensures optimum system control, and includes a wealth of additional tools.
  - Ethernet™* provides powerful local area networking capability.
- Human Interface** The SCALDsystem™ is universally recognized as being the easiest-to-use CAE system in the industry.
  - On-screen menus* (graphics tablet-selected) plus keyboard entry provide fast, easy command selection, schematic entry, and analysis control.
  - Windows* allow several programs to be run on the SCALDsystem™ and viewed on its screen simultaneously.
  - Variable scaling, zoom, and pan* allow you to see as much or as little detail as needed.

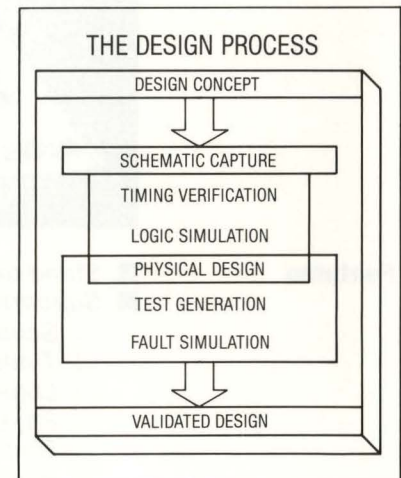

## Summary of Major Features (continued)

- All analysis tools use a *common data base*—derived directly from the design schematic—greatly simplifying the total design cycle.
- SIZE and BUS abstractions* make schematics easier to create and read, and speed up timing and functional analysis.
- All *operations are consistent*, whether the software tools are run locally on one of Valid's SCALDsystems or remotely on a mainframe computer.
- **Design Capacity.** The SCALDsystem™ is capable of handling designs from just a few devices to those containing several million gates. And they can handle all types of integrated circuit devices, from simple TTL to the most complex VLSI microprocessors.
  - Supports *hierarchical design* to permit representation and analysis of a design at any level.
  - Contains up to *12 megabytes of RAM, with 14 megabytes of virtual memory* for each process.
  - Over 2,000 devices in the TTL, ECL, standard cell, gate array, and memory *device libraries* make it possible to create designs for implementation in printed circuit boards or semi-custom chips.
  - Supports *Realchip™ modeling* for those designs containing complex VLSI chips such as microprocessors, peripheral chips, and custom or semi-custom chips.
  - Supports *Realfast™ simulation* for multi-million gate design capacity.
- **Simulation Speed.** The simulation speed you need depends on the size and complexity of your design. When using the SCALDsystem™, there are three simulation configurations available to you.
  - The *SCALD Logic Simulator*, running on the standard SCALDsystem™ hardware, simulates over 1,000 events per second, including designs containing microprocessors and other complex VLSI chips when the Realchip™ Modeling System is part of the configuration.
  - Running the *SCALD Logic Simulator* on a *DEC VAX™ 11* or *IBM 370 mainframe* increases simulation speed for random logic designs by a factor of two to ten.
  - For larger designs (even those with millions of gates), the *Realfast™ Simulation System* increases simulation speeds to 500,000 evaluations per second: five times faster than any other comparably priced simulation accelerator, and more than an order of magnitude faster than mainframe-based simulations. In addition, it is compatible with the Realchip™ Modeling System for simulation of designs containing complex VLSI devices.
  - When the design is finished and ready to go into production, the powerful *LASAR™* test generation and fault simulation package helps develop test programs for ATE systems.
- **Economic Considerations.** Valid offers workstation configurations that can be tailored to individual engineering environments, at very competitive per-station prices.
  - SCALDsystem™ I* is usually the most economical choice. It provides the most economical per-station cost for any full-function workstation, particularly when several workstations are needed.
  - SCALDsystem™ II* is a high-performance configuration where a dedicated disk is required (e.g., for file security purposes), or when a workstation must be located too far from other stations to be connected to a SCALDsystem I cluster controller.

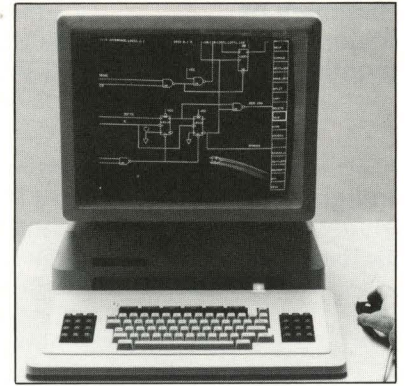



### Summary of Major Features (continued)

- Ethernet™ *local area networking* enables any SCALDsystem™ configuration (SCALDsystem™ I or SCALDsystem™ II) to be part of a network that includes other SCALDsystems™ or Valid SCALDstar™ VLSI design systems.

### Integrated Hardware and Software Tools

Valid's SCALDsystem™ provides customized, integrated hardware and software tools to perform those functions which lead from a design's initial concept to total design validation.

- **Schematic Capture.** Schematics are created on a high resolution screen, using logic symbols from the SCALDsystem's device libraries or user-defined symbols. When the schematic is done, it contains all the information from which the design data base is created.
- **Timing Verification.** The schematic is analyzed to detect timing errors such as set-up and hold violations, clock glitches, pulse width errors, and race conditions.
- **Logic Simulation.** Once timing problems are resolved, the schematic is exercised as if it were a hardware breadboard to determine the circuit's functional characteristics and to detect design errors.
- **Physical Design.** Parts lists and interconnect (net) lists are generated, and physical design rule checks are made. Component placement and interconnection plans for implementation on a printed circuit board or on silicon are made.
- **The ATE Connection.** The logical and physical designs are analyzed for testability, and production test software may be generated. Test patterns may be graded using concurrent fault simulation.

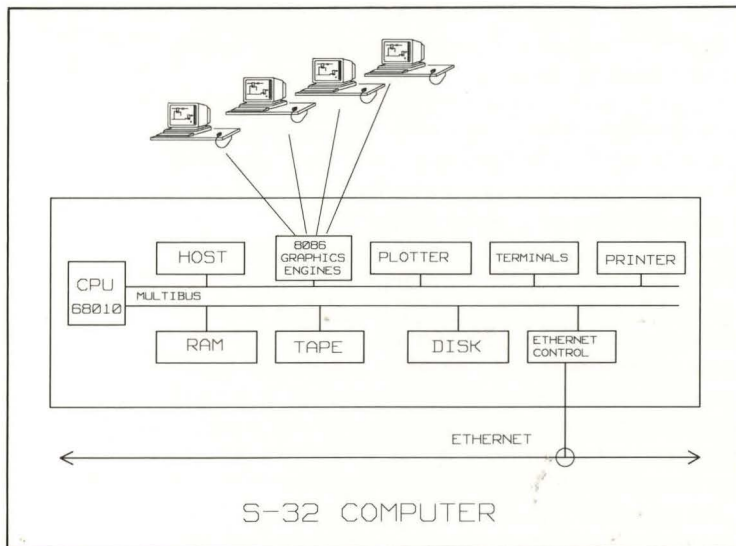

### Hardware Tools

All SCALDsystem™ configurations are constructed from a set of common tools, configured to meet particular system objectives. The common tools are described first, with specific configurations following. Capacities (RAM, hard disk, etc.) given in the overall descriptions are maximums. Individual configuration descriptions define specific capacities.



### S-32 Computer

The S-32 computer provides control and processing functions for SCALDsystem™ I and SCALDsystem™ II. It includes the CPU, working memory, disk storage, magnetic tape, peripheral interfaces, Ethernet™ controller, and interfaces to the Realchip™ and Realfast™ systems.



**S-32 Computer  
(continued)**

- **6810 Microprocessor.** The Motorola 68010 micro-processor provides the S-32 with powerful processing and virtual memory capability.
- **Memory: Real and Virtual.** Memory capacity is 12 Megabytes of RAM with 14 Megabyte virtual memory for each process, giving the SCALDsystem™ the ability to handle large designs.
- **Winchester Disks.** From 70 to 280 Megabytes of hard disk storage are available, in 70 Megabyte increments.
- **Magnetic Tape.** Disk backup and archiving are handled with an industry-standard 1600 bpi, 1/2-inch tape drive (SCALDsystem™ I), or 1/4-inch cartridge tape drive (SCALDsystem™ II).
- **Peripheral and Host Interfaces.** Interfaces to pen plotters, electrostatic plotters, line printers, and mainframe computers may also be installed in the S-32 computer.
- **Ethernet™ Interface.** The Ethernet™ interface is an option with the S-32 computer. Each workstation, whether stand-alone or part of a cluster, accesses Ethernet™ via a controller board in its associated S-32 computer.

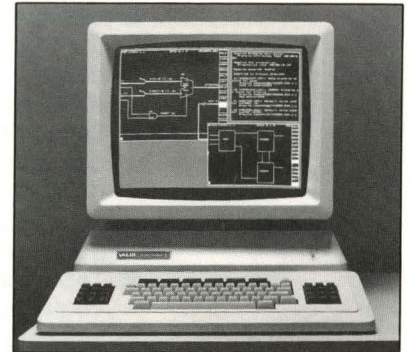
**Workstation**

The SCALDsystem™ workstation is designed for the way engineers work. It has a large screen to provide large design displays as well as on-screen menus. It features a built-in graphics tablet for easy command entry, component placement, and component interconnection. Since a workstation is used extensively for schematic capture, each workstation has its own graphics engine for faster graphics response.

- **Monochrome Screen.** The screen is large (20 inches, diagonal) so that more design information can be displayed. It features very high resolution (1024 x 800 pixels) for displaying designs in very fine detail. More windows can be displayed, with excellent detail in each window. Each pixel is represented by two bits, permitting four levels of intensity. The CRT is anti-glare, with tilt and swivel adjustments for easy viewing.
- **Color Screen (Optional).** Color provides another dimension of information to the designer. Both the SCALDsystem™ I and SCALDsystem™ II are available with optional high-resolution color screens.
- **Dedicated Graphics Engine.** A CAE workstation is used most frequently for schematic capture, and many companies buy them just for that purpose. In order to ensure fast interactive schematic entry, each SCALDsystem™ workstation has its own dedicated 8086 graphics engine, plus 272K bytes of dedicated memory.
- **Graphics Tablet.** Menu selections, component placement, and schematic wiring are accomplished using the graphics tablet and puck. The puck not only locates positions on the screen, but also has four control buttons, reducing the need for typed commands and speeding up graphics entry and simulation control.
- **Detached Keyboard.** The keyboard provides command and data entry, both through the alphanumeric keys and the twenty-six programmable function keys.

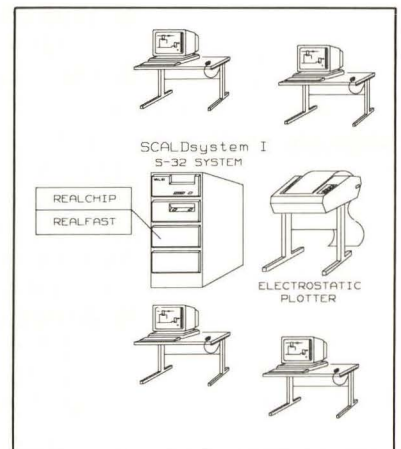
**SCALDsystem™ I  
Configuration**

Valid's SCALDsystem™ I consists of a central cluster controller and up to four workstations. The workstations share a central S-32 computer and disk storage where programs and files are stored, and where all the SCALD analysis programs are run.



**SCALDsystem™ I Configuration (continued)**

SCALDsystem™ I characteristics are:

- **Cluster Controller.** Workstations are connected to a central cluster controller containing the S-32 computer, RAM, disks, tape drive, and interfaces. It has 23 card slots, enabling it to hold a full complement of memory, dedicated workstation 8086 graphics engines, Ethernet™ controller, Realchip™ master boards, and Realfast™ interface boards.
- **Workstations.** Up to four workstations may be attached to the cluster controller and may be located up to 500 feet away.
- **RAM capacity:** 2 to 12 Megabytes.
- **Disk capacity:** 70 to 2,020 Megabytes. The amount of disk storage required depends on the number and size of designs to be stored. If more is required, one or more file servers (an S-32 computer with more disk storage) may be made available via Ethernet™.
- **Tape (backup and software loading):** 1/2" reel, 1600 bpi, or 1/4", 45 Mb tape cartridge. Valid distributes software updates on magnetic tape (floppy disks do not have the necessary capacity), and disks should be backed up on tape. The SCALDsystem™ I tape system provides the necessary speed and capacity for these operations.
- **Realfast™/Realchip™ Compatible.** The Realfast™ Simulation Accelerator and the Realchip™ Modeling System may be connected directly to the SCALDsystem™ I cluster controller for use by all connected workstations.

**SCALDsystem™ II Configuration**

SCALDsystem™ II is a stand-alone version of Valid's popular SCALDsystem. It looks very much like a single SCALDsystem™ I workstation, differing only in an enclosure on the back which houses an S-32 computer, memory, disk drive, tape drive, and interfaces.

This system is popular when it is desirable for each engineer to have a totally dedicated workstation. SCALDsystem™ II is priced lower than most competitive stand-alone systems with comparable performance.

SCALDsystem™ II characteristics are:

- **Stand-alone system** with S-32, RAM, disks, tape, and interfaces integrated into the workstation. Its 10-slot backplane will also house an Ethernet™ interface board and peripheral interface boards.
- **Color Screen (Optional).** SCALDsystem™ II is available with an optional high-resolution color screen. (A monochrome screen is standard.)
- **RAM capacity:** 2 to 4 Megabytes.
- **Tape (backup and software loading):** 1/4" cartridge, 45 Megabyte capacity.
- **Disk capacity:** 70 Megabytes.

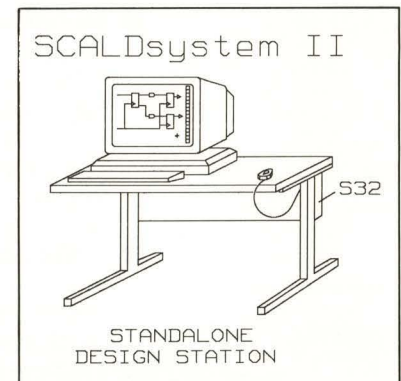
**Software Tools**

Valid's SCALDsystem™ runs the proven SCALD analysis software plus other software tools that are useful in the engineering environment. Each of the tools described below is covered in detail in a separate data sheet. This brief description shows their relationship to each other, and their functions in the design cycle.

- **Device Libraries.** Valid's device libraries contain over 2,000 models from many commonly used logic families: TTL (including Schottky and low-power Schottky), ECL, CMOS, memory devices, and gate arrays. In addition, Valid Primitive libraries are included for use in developing other libraries. Additional libraries enable designers to develop

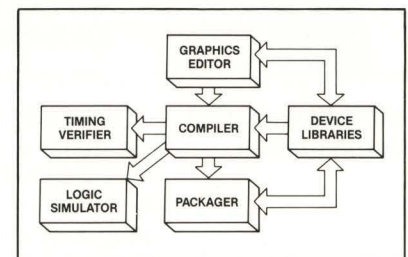

**Software Tools  
(continued)**

designs for analysis on other systems such as HILO, LOGCAP, MCLDL, SPICE, and TEGAS-5.

In addition to these software libraries, the Realchip™ Modeling System adds a wide variety of complex VLSI device models that cannot be handled with software models.

DEVICE LIBRARIES					
SSI/MSI	LSI/VLSI	PRIMITIVES	GATE ARRAYS	Realchip™	LASAR
LSTTL STTL TTL FAST HCMOS 10K ECL 100K ECL CMOS	Static Memory Dynamic Memory PAL 20 IFL	Standard Phantom Time Simulation SPICE TEGAS 5 LOGCAP HILO MCLDL	MCA 1200 HCA 6348 C8000 LSI 5000* AMD 1850	2900 68000 Z 80 16032 8086 8085	ASTTL TTL LSTTL STTL ALSTTL FAST HCMOS CMOS 10K ECL 100K ECL

\*Distributed through LSI Logic Inc.

- **Graphics Editor.** The SCALD Graphics Editor is a drawing tool specifically developed for creating electronic designs. It may be used to create block diagrams, and then to expand each block into a detailed schematic. The same editor is used for both schematic capture and the creation of new body drawings for inclusion in the device library. Additional features are:

- Menu driven.
- Variable scaling, zoom, and pan.
- Built-in recovery (UNDO and REDO commands).
- Supports mixed text and graphics.
- Back-annotates schematics.

- **Timing Verifier.** The SCALD Timing Verifier detects and reports logic-level timing errors: set-up times, hold times, pulse width (both high and low assertion levels), edge-to-edge time, and glitches (gated clocks). It works directly from the design data base derived from the designer's compiled drawings, and provides its own stimuli to the design. It provides an exhaustive analysis of all possible timing conditions in the design. Additional features are:

- Verifies partial or complete designs.
- Value-independent timing simulation (24 signal states).
- Uses worst-case min/max timing.
- Verifies designs using open-collector, open-emitter and three-state devices.
- Handles asymmetric rise and fall times.
- Estimates delay as a function of load.
- Verifies pass-transistor circuits.
- Handles reconvergent fan-out analysis.
- Handles wire delays and wire delay files.
- User-definable clock skew.
- Automatic convergence.

- **Logic Simulator.** The SCALD Logic Simulator is an interactive simulator that is used to verify correct logical behavior in a design. It handles partially completed designs, mixed high-level and low-level simulations, and behavioral models as well as functional models. It works from the common design data base. Additional features include:

- Simulates 20 signal states.
- Bi-directional transfer gates (for MOS design).
- Supports Realchip™ simulation models.
- Compatible with Realfast™ Simulation Accelerator.



**Software Tools  
(continued)**

- Uses actual, worst-case component delays.
- Event driven.
- Multiple bit devices and buses simulated in parallel.
- Simulates high-level primitives.
- Waveform, bus mode, or tabular output.
- Behavioral simulation capability.

■ **Packager.** The SCALD Packager is a physical design and analysis tool that converts a logical design created by the Graphics Editor into a packaged design. Some of its functions are: detecting fanout violations, generating package and pin assignments, expanding vectored components (i.e., components with SIZE parameters and multi-bit buses), and automatic load balancing. Additional features are:

- Performs physical analysis of the design.
- Provides update support for engineering changes.
- Checks for unconnected signals.

■ **Interfaces to Other Systems.** A SCALDsystem™ is frequently used as a front-end to another system. For example, a packaged design may be transported to another system such as APPLICON, REDAC, SCICARDS or TELESIS for printed circuit board component placement and interconnect routing. Valid provides a wide variety of conversion programs for interfacing to other systems. Refer to the INTERFACE Data Sheet for a complete list.

In addition, Valid's DIAL (Design Interface and Access Library) provides a convenient means for SCALDsystem users to create their own custom interfaces.

■ **Test Generation.** Valid's SCALDsystem™ supports the powerful Teradyne LASAR™ simulator for test generation and concurrent fault simulation, using the design data base as source information. Test programs generated by LASAR™ can be formatted for use on Teradyne and most other popular ATE systems. Some LASAR™ characteristics are:

- Runs on SCALDsystem™ I, SCALDsystem™ II, or DEC VAX™.
- Includes both simulation and timing analysis.
- Good circuit simulator and fault simulator operate in both interactive and batch modes.
- Post processor converts test programs to tester-specific formats.

**Special Tools:  
Realchip™ and  
Realfast™**

As the CAE industry matures, two problems are becoming very clear: (1) the need for simulation models of complex VLSI devices such as microprocessors and their associated chips, and (2) the need for greater simulation speed and capacity.

Valid offers two separate but compatible products to address these two problems: The Realchip™ Modeling System and the Realfast™ Simulation Accelerator. These two products are described briefly here, and are covered in detail in their separate data sheets.

■ **Realchip™ Modeling System.** The Realchip™ Modeling System works with Valid's SCALDsystem™ I to address the problem of simulating designs containing complex VLSI devices such as microprocessors, complex peripheral chips, communications chips, semi-custom chips, and even full custom chips.

Using Realchip™ models, designs containing devices such as the Motorola 68000/10/20, the Intel 8086/87/88 and 80186/286, the Zilog Z80, and the NSC 16032/32032 can be modeled.



**Special Tools  
Realchip™ and  
Realfast™  
(continued)**

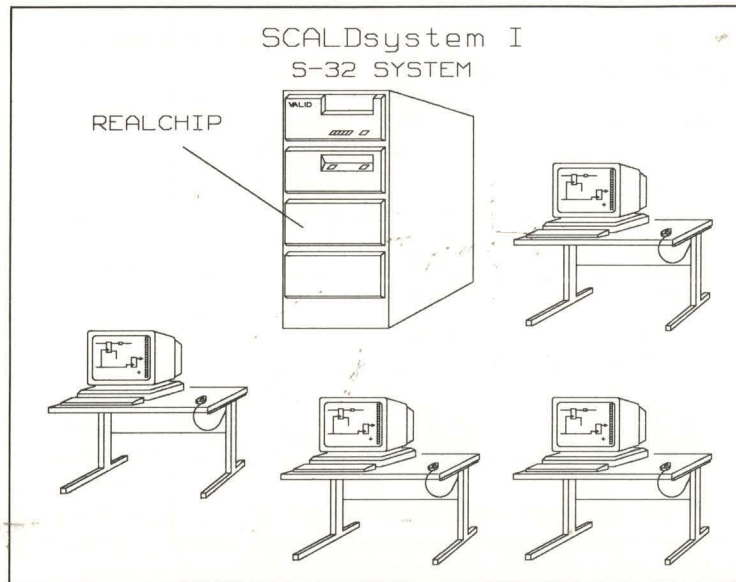

Primary Realchip characteristics are:

- Models any complex VLSI devices (microprocessors, complex peripherals, custom, etc.).
- Simulates orders of magnitude faster than equivalent software models.
- Compatible with Realfast™ for total system simulation.
- Models are easily crated and updated.
- Handles up to 64 separate models (4,096 channels), with only one reference element for a device needed, regardless of the number of times the device is used in the design.

■ **Realfast™ Simulation Accelerator.** Modern CAE systems must be able to validate multi-million gate designs at very high simulation speeds. With many CAE systems, this means buying a totally new system. With the SCALDsystem™, however, this capacity is achieved by the addition of the Realfast™ Simulation Accelerator. Its features include:

- Five times faster than comparably priced simulation accelerators—500,000 evaluations per second.
- Handles designs containing almost three million gates.
- Works with Realchip™ for total design validation.
- Simulation memory is expandable to 64 megabytes.

**Networking**

Local area networks allow workstations to provide virtual terminal support for remote login, share files, and exchange electronic mail. The flexibility of Valid's SCALDsystem™ when coupled with UNIX™ and Ethernet™, makes networking a relatively straightforward process.

This section discusses some basic network configurations. They should in no way be considered complete—but merely some samples of many possible configurations.

■ **SCALDsystem™ I Cluster.** The simplest network is the basic SCALDsystem™ I cluster. Each workstation in the cluster has access to all files (although files can be password-protected). No special interfaces are required, and communication between workstations is via the S-32 computer. Adding Realchip™ and Realfast™ to the cluster gives each workstation the ability to handle even the most complex designs.

■ **Two Clusters.** Two or more SCALDsystems™ can be connected via Ethernet™. With Valid's new Distributed File

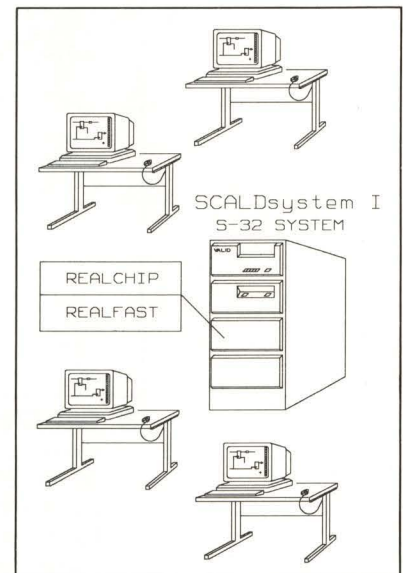

**Networking  
(continued)**

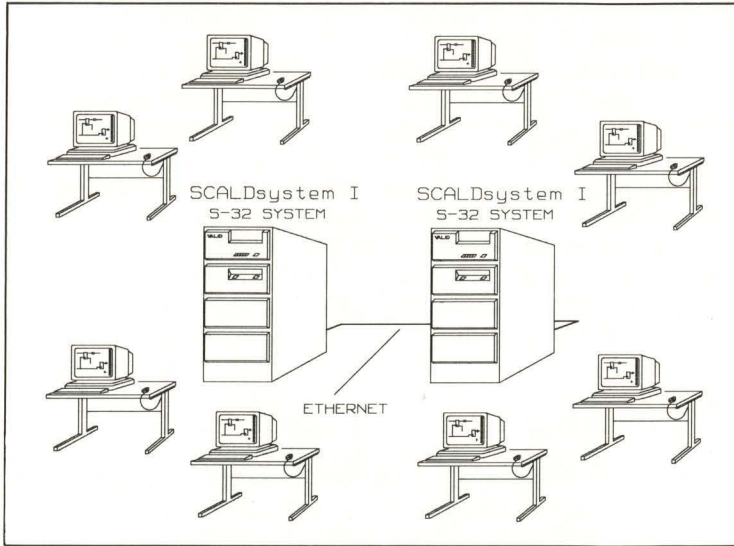

System operating under UNIX™, each workstation has access to all files within the system.

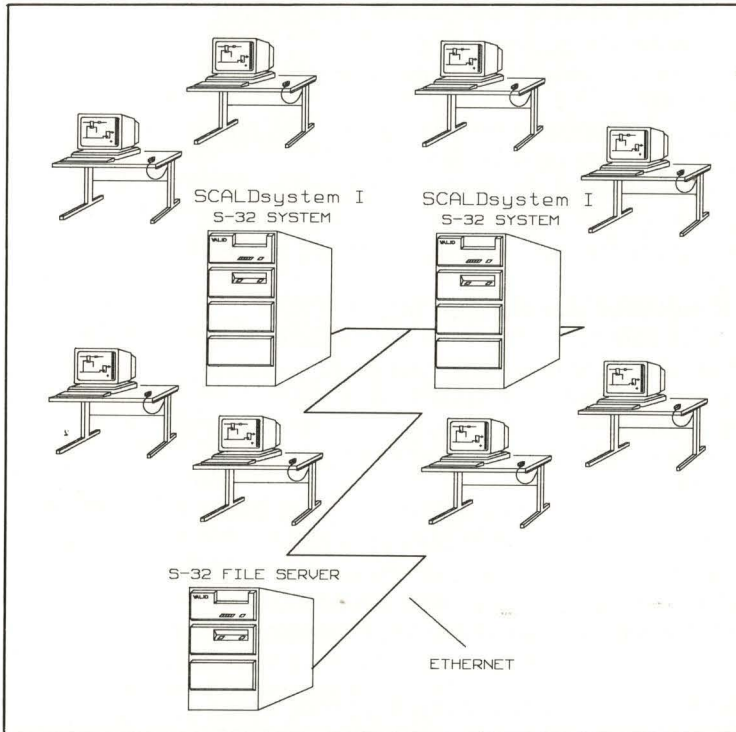

- **Two Clusters With File Server.** Disk storage capacity within a system can be increased by the use of file servers on the Ethernet™ network. The file server is an S-32 computer with additional disk memory (to 2 Gigabytes). Each workstation on the network can access the file server for data files.
- **Two Clusters, File Server, Realchip™, and Realfast™.** Realchip™ and Realfast™ may be added to a network by attaching them to one of the cluster controllers. Schematic capture is handled locally; but when a simulation requiring VLSI models or very high speeds must be performed, it is run on the cluster with Realchip™ and Realfast™.

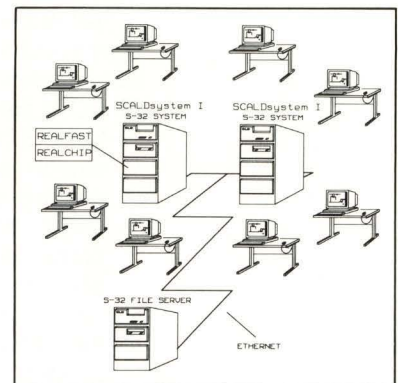



**Networking  
(continued)**

- **Cluster, SCALDsystem™ II, File Server, Realchip™, Realfast™.** A SCALDsystem™ II can be placed on an Ethernet™ network so that it can communicate with other systems and can access the file server.
- **Cluster, SCALDsystem™ II, SCALDstar™.** Logic designs for implementation in custom chips may be done on a SCALDsystem™, but final placement and routing must be done on a VLSI design system such as Valid's SCALDstar™. With this network, custom and semicustom designs can be accessed by the SCALDstar™ for physical layout.

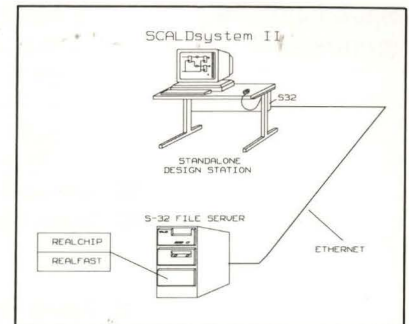
**Mainframe  
Connections**

Many of the SCALD analysis tools can be run interactively on a mainframe computer as well as locally on an S-32 or remotely on a file server.

Interfacing to a mainframe computer provides several advantages:

- Mainframes provide higher speed for some programs.
- Mainframes may have more memory available for processing larger designs.
- Users may have proprietary software on the mainframe computer which does not run on the SCALDsystem™ hardware. It is frequently necessary to run simulations on a SCALDsystem™ rather than a mainframe, because the mainframe cannot take advantage of Realchip™ models or Realfast™ speed. A mainframe is particularly useful, however, for running batch-oriented programs such as the Timing Verifier, the Compiler, and the Packager.
- Mainframe Compatibility:
  - IBM 370, RSCS (bisync); 3277 Emulation.
  - DEC VAX-11; VT100 Emulation.

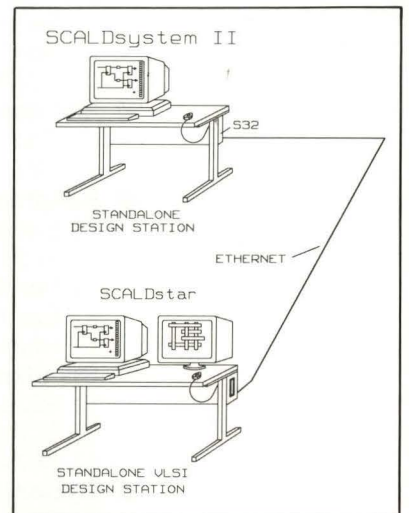
**Specifications**

- **SCALDsystem™ I:**
  - Cluster controller containing S-32 computer, RAM, disks, tape and interfaces.
  - Up to four workstations with monochrome or optional color screens.
  - RAM capacity: 2 to 12 Megabytes.
  - Disk capacity: 70 to 2,020 Megabytes.
  - Tape (backup and software loading): 1/2" reel, 1600 bpi, 70 Megabyte capacity, or 1/4" tape cartridge with 45 Megabyte capacity.
  - Realfast™/Realchip™ compatible.
  - Ethernet™ compatible.
- **SCALDsystem™ II:**
  - Stand-alone system with S-32, RAM, disks, tape and interfaces integrated into workstation.
  - Workstation is available with standard monochrome screen or optional color screen.
  - RAM capacity: 4 Megabytes.
  - Tape (backup and software loading): 1/4" cartridge, 45 Megabyte capacity.
  - Disk capacity: 70 Megabytes.
  - Ethernet™ compatible.
- **S-32 Computer:**
  - 68010 Central Processor.
  - 14 Megabyte Virtual Memory.
- **Workstations:**
  - 8086 Graphics Processor.
  - 1024 x 800 Monochrome Screen Standard.
  - Color Screen Optional.

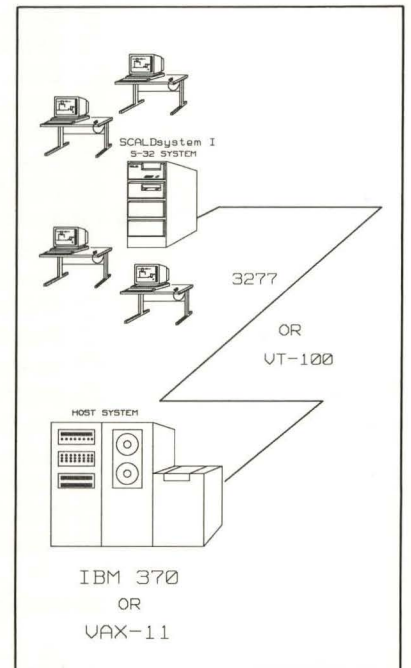

**Specifications  
(continued)**

- 60 Hz Non-interlaced Raster (Monochrome).
- Anti-glare CRT.
- Detachable Keyboard.
- 26 Programmable Function Keys.
- Built-in Graphics Tablet.
- Tilt and Swivel Adjustments.
- **Networking:** Ethernet™.
- **Tape Back-up and Software Loading:**
  - 1/2", 1600 bpi (SCALDsystem™ I).
  - 1/4" Cartridge, 45 Mb capacity (SCALDsystem™ II).
- **Realchip™, Realfast™ Compatibility:**
  - Host to Realchip™ Modeling System (Cluster or S32 Server).
  - Host to Realfast™ Simulation Accelerator (Cluster or S32 Server).
- **Mainframe Compatibility:**
  - IBM 370, RSCS (bisync); 3277 Emulation.
  - DEC VAX-11; VT100 Emulation.
- **Peripherals:**
  - Electrostatic Plotter, 11" to 42", Plots B-Size Drawings in 30 seconds.
  - Pen Plotter, D and E sizes.
  - Color Plotter.
  - High-speed Printer.
- **Standard Software:**
  - SCALD Graphics Editor.
  - SCALD Compiler.
  - SCALD Packager.
- **Optional Software:**
  - SCALD Timing Verifier.
  - SCALD Logic Simulator.
  - SPICE Circuit Simulator.
  - DIAL.
  - Device Libraries.
  - Interfaces to Other Analysis/Physical Design Tools.
  - Pascal Compiler.
  - FORTRAN 77 Compiler.
- **Operating System and Utilities:**
  - UNIX™ Operating System, Valid extensions based on Berkeley 4.1 C BSD.
  - C Compiler.
  - 68000/68010 Assembler.
  - vi, ex, ed Text Editors.
  - nroff Documentation Formatter.
  - ac, sa Accounting.
  - uucp, cu Communications.
  - Window Manager.
  - Mail Processor.
  - Word Processing.

Specifications subject to change without notification.

**Valid Logic Systems Incorporated**  
**Valid International**

• 2820 Orchard Parkway, San Jose, California 95134 USA  
• Berkshire House, 56 Hershel Street, Slough SL1 1PY U.K.

• (408) 945-9400, Telex 371-9004  
• (0753) 820101, Telex 847 318

©Copyright 1984 Valid Logic Systems Incorporated.

SCALDsystem, SCALDstar, Realchip and Realfast are trademarks of Valid Logic Systems Incorporated.

VAX/VMS are trademarks of Digital Equipment Corporation.

VM is a trademark of IBM.

UNIX is a trademark of A.T.&T.

Ethernet is a trademark of Xerox Corporation.

LASAR is a trademark of Teradyne Incorporated.

Printed in U.S.A.  
2502 JP 20K 07/84