



IBM Data Migration Kit

User's Guide

OPTIONS
by IBM

Note: Before using this information and the product it supports, be sure to read the information under “Appendix B. Product warranty and notices” on page B-1.

First Edition (August 2001)

© Copyright International Business Machines Corporation 2001. All rights reserved.
US Government Users Restricted Rights – Use, duplication or disclosure restricted by
GSA ADP Schedule Contract with IBM Corp.

Contents

Safety: Read first	v
About this book	vii
Registering your option	vii
Installation and user's guide.	1-1
Product description	1-1
Supported operating system combinations	1-2
System requirements	1-2
The data migration process	1-3
Installing the Ethernet adapter in the previous computer	1-3
Installing the Ethernet adapter in a desktop computer (Desktop with PCI Kit)	1-3
Installing the Ethernet adapter device drivers in a desktop computer	1-4
Installing the Ethernet adapter in a mobile computer (Mobile with PC Card Kit)	1-9
Installing the Ethernet PC Card with Windows 2000, Windows Me, Windows 98 and Windows 95	1-9
Windows 98	1-10
Windows 95	1-10
Installing the IBM Data Transfer software.	1-10
Installing the IBM Data Transfer software on the previous computer	1-11
Installing the IBM Data Transfer software on the new computer	1-14
Performing the data migration	1-19
Begin transfer process on the new computer.	1-20
Appendix A. Help and service information.	A-1
Warranty information on the World Wide Web	A-1
Online technical support	A-1
Telephone technical support	A-1
Appendix B. Product warranty and notices	B-1
Warranty Statement	B-1
IBM Statement of Limited Warranty	B-1
Part 1 - General Terms	B-1
Part 2 - Country-unique Terms	B-4
Processing date data.	B-12
Trademarks.	B-13
Electronic Emissions Notices	B-13
Federal Communications Commission (FCC) statement	B-13
Appendix C. Troubleshooting, hints and tips	C-1
Troubleshooting	C-1

Hints and tips	C-2
Logging on to your Windows computer with a user name and password	C-2
Changing a user name password on your Windows computer	C-4
Changing the name of a Windows computer	C-5
Windows 2000	C-5
Windows Me, Windows 98, and Windows 95.	C-5
Disabling file and print sharing	C-5
Windows 2000	C-5
Windows Me, Windows 98, and Windows 95.	C-6

Safety: Read first

Before installing this product, read the Safety Information.

مج، يجب قراءة دات السلامة

Antes de instalar este produto, leia as Informações de Segurança.

在安装本产品之前，请仔细阅读 **Safety Information** (安全信息)。

Prije instalacije ovog produkta obavezno pročitajte Sigurnosne Upute.

Před instalací tohoto produktu si přečtete příručku bezpečnostních instrukcí.

Læs sikkerhedsforskrifterne, før du installerer dette produkt.

Ennen kuin asennat tämän tuotteen, lue turvaohjeet kohdasta Safety Information.

Avant d'installer ce produit, lisez les consignes de sécurité.

Vor der Installation dieses Produkts die Sicherheitshinweise lesen.

Πριν εγκαταστήσετε το προϊόν αυτό, διαβάστε τις πληροφορίες ασφάλειας (safety information).

לפני שתתקינו מוצר זה, קראו את הוראות הבטיחות.

A termék telepítése előtt olvassa el a Biztonsági előírásokat!

Prima di installare questo prodotto, leggere le Informazioni sulla Sicurezza.

製品の設置の前に、安全情報をお読みください。

본 제품을 설치하기 전에 안전 정보를 읽으십시오.

Пред да се инсталира овој продукт, прочитајте информацијата за безбедност.

Lees voordat u dit product installeert eerst de veiligheidsvoorschriften.

Les sikkerhetsinformasjonen (Safety Information) før du installerer dette produktet.

Przed zainstalowaniem tego produktu, należy zapoznać się z książką "Informacje dotyczące bezpieczeństwa" (Safety Information).

Antes de instalar este produto, leia as Informações sobre Segurança.

Перед установкой продукта прочтите инструкции по технике безопасности.

Pred inštaláciou tohto zariadenia si pečítajte Bezpečnostné predpisy.

Pred namestitvijo tega proizvoda preberite Varnostne informacije.

Antes de instalar este producto lea la información de seguridad.

Läs säkerhetsinformationen innan du installerar den här produkten.

安裝本產品之前，請先閱讀「安全資訊」。

About this book

This guide contains information on the IBM® Data Migration Kit. The guide is divided into two parts:

Part 1: Installation and user's guide

This section contains the product description, installation, and operating instructions, and is translated into the following languages:

- French
- German
- Spanish
- Italian
- Brazilian Portuguese
- Traditional Chinese
- Japanese

Part 2: Appendixes

This section contains help and service, warranty, and notice information.

Be sure to retain your proof of purchase. It might be required for warranty service.

Registering your option

Thank you for purchasing OPTIONS by IBM®. Please take a few moments to register your product and provide us with information that will help IBM to better serve you in the future. Your feedback is valuable to us in developing products and services that are important to you, as well as in developing better ways to communicate with you. Register your option on the IBM Web site at

<http://www.ibm.com/pc/register>

IBM will send you information and updates on your registered product unless you indicate on the Web site questionnaire that you do not want to receive further information.

Installation and user's guide

This guide contains the product description, hardware and software installation instructions, and product use.

Note: Please check the IBM Support Web site for additional hints and tips on using this option. To access the Web site, follow these instructions:

1. Point your Web browser to <http://www.pc.ibm.com/support>
2. In the Browse the support site pull-down menu, select **Options**.
3. On the IBM Options Support page, select **Data Migration** from the Category pull-down menu.
4. On the Data Migration Support page, make the appropriate selection for the Subcategory menu.
5. When the Web page refreshes, select the appropriate data migration kit underneath **Option**.

Product description

The IBM Data Migration Kit provides an easy way to quickly copy Microsoft® Windows® desktop settings, network settings, Internet bookmarks and data files from a previous computer to a new computer. The migration process is managed by the IBM Data Transfer software program and uses Ethernet adapters to transfer the data and settings from the previous computer to the new computer.

The IBM Data Migration Kit package includes:

- IBM Data Migration User's Guide and Software CD
- *IBM Data Migration Kit User's Guide*
- *Safety Information* book
- Crossover cable
- PCI Ethernet adapter for desktop computers (Desktop with PCI Kit only)
- Ethernet PC Card and converter cable for mobile computers (Mobile with PC Card Kit only)

To use the IBM Data Migration Kit, you must have an Ethernet adapter already installed in the new computer. The Desktop with PCI Kit and the Mobile with PC Card Kit each include an Ethernet adapter that should be installed in the previous computer, if that computer does not already have an Ethernet adapter.

Contact your place of purchase if an item is missing or damaged. Be sure to retain your proof of purchase and packing material. They might be required to receive warranty service.

You can perform data-migration process between two computers with Windows operating systems. The computers can have different operating systems; however, not all Windows operating-system combinations are supported. See “Supported operating system combinations” below.

Supported operating system combinations

The following table includes all supported operating system combinations:

Previous computer operating system	New computer operating system
Windows 2000 Professional	Windows 2000
Windows Millennium (Me)	Windows Me
Windows 98 Second Edition (SE)	Windows 2000, Windows Me, Windows 98 SE, Windows 98,
Windows 98	Windows 2000, Windows Me, Windows 98 SE, Windows 98,
Windows 95	Windows 2000, Windows Me, Windows 98 (SE), Windows 98, Windows 95

System requirements

The computers that you are transferring data between do not have to be the same type. For example, you can transfer data from a desktop to a mobile computer and vice versa. The following are requirements for the new and previous computer.

New computer

- Pentium-class system or above
- Windows 2000, Windows Me, Windows 98 SE, Windows 98, Windows 95
- 32 MB Memory
- Free space on hard drive equal to the amount of data to be transferred
- Ethernet adapter

Previous computer

- Pentium-class system or above
- Windows 2000, Windows Me, Windows 98 SE, Windows 98, Windows 95
- 32 MB Memory
- Free space on hard drive equal to the amount of data to be transferred
- Available PCI slot (Desktop with PCI Kit only)
- Available PC Card slot (Mobile with PC Card Kit only)

The data migration process

To use the IBM Data Migration Kit, your new IBM computer must already have an Ethernet adapter. Your previous computer will also need an Ethernet adapter. If your previous computer does not already have an Ethernet adapter, you should have purchased the Desktop with PCI Kit for desktop computers or the Mobile with PC Card Kit for mobile computers. Each of these kits contains an Ethernet adapter that you can install in your previous computer. If your previous computer already has an Ethernet adapter, you should have purchased the Basic Kit.

The data migration consists of these basic steps:

1. Install the Ethernet adapter and device drivers in your previous computer. Skip this step if your previous computer already has an Ethernet adapter.
2. Install the IBM Data Transfer software on your previous computer.
3. Install the IBM Data Transfer software on your new computer.
4. Connect the Ethernet ports on your new computer and previous computer using the crossover cable included in the kit.
5. Perform the data migration using the IBM Data Transfer program.

Installing the Ethernet adapter in the previous computer

This section contains instructions for installing the Ethernet adapter and device drivers in your previous computer.

- If you already have an Ethernet adapter in your previous computer, go directly to “Installing the IBM Data Transfer software” on page 1-10.
- If you are installing the Ethernet adapter in a desktop computer, follow the instructions beginning in the next section, “Installing the Ethernet adapter in a desktop computer (Desktop with PCI Kit)”.
- If you are installing the Ethernet adapter in a mobile computer, skip to “Installing the Ethernet adapter in a mobile computer (Mobile with PC Card Kit)” on page 1-9.

Installing the Ethernet adapter in a desktop computer (Desktop with PCI Kit)

Follow these steps to install the PCI Ethernet adapter (from the Desktop with PCI Kit only) in your previous computer:

1. Shut down Windows (if it is running) by clicking the **Start** button, and then clicking **Shut Down**.
2. Turn off and unplug the computer from the electrical outlet before removing the computer cover.

Note: Follow the instructions provided in your computer manual for removing the cover or otherwise accessing the PCI adapter slots, and installing a PCI adapter. Be sure to follow any safety instructions in that manual.

3. Remove the cover bracket from a PCI slot by removing the screw that secures it.

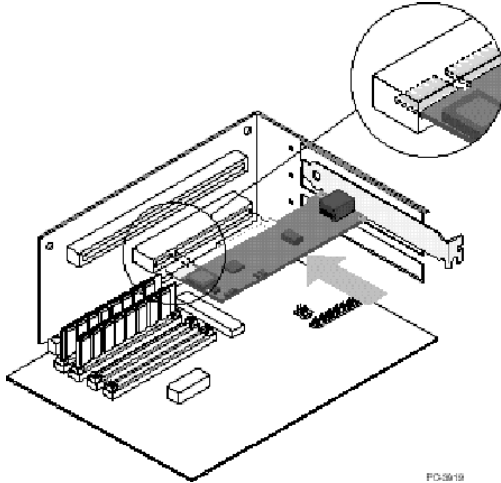

4. Insert the PCI Ethernet adapter into a PCI slot, and push it into the slot until it is firmly seated. Then secure the adapter bracket with the screw that you removed in step 3. Your adapter slots or PCI connector might differ from the illustration.
5. Replace the computer cover.
6. Plug in the power cord.
7. Turn on the power.
8. Follow the instructions in the next section to install the Ethernet device drivers.

Installing the Ethernet adapter device drivers in a desktop computer

Follow the instructions for the operating system on your previous computer to install the device drivers for the PCI Ethernet adapter.

Note: Device drivers are necessary for the PCI Ethernet adapter to function. Windows will prompt for the driver installation disk on restart.

Windows 2000

Follow this procedure to install the Ethernet device drivers in Windows 2000:

1. After you install the PCI Ethernet adapter in the computer, plug in the power cord and start the computer. The Found New Hardware window opens, and the Found New Hardware Wizard starts.

2. Insert the *IBM Data Migration User's Guide and Software CD* into the CD-ROM drive, if not already inserted. If a browser window automatically starts, close the window.
3. In the New Hardware Wizard Welcome window, click **Next**.
4. In the next window, click **Search**, and then click **Next**.
5. Select the **CD-ROM** box in the **Locate Driver** window, and click **Next**.
6. When the Search Results indicates a driver was found on the CD, click **Next** to continue.
7. If a Digital Signature message is displayed, click **Yes** to continue.
8. The files are copied to your computer. When a Completed message is displayed, click **Finish**.
9. Proceed to "Installing the IBM Data Transfer software" on page 1-10.

Windows Me

Follow this procedure to install the Ethernet device drivers in Windows Me:

1. After you install the adapter in the computer, start the computer. Windows Me detects the adapter and the Add New Hardware Wizard starts.
2. Click **Next**.

Note: If this Add New Hardware window does not display and Windows Me starts normally, you may need to manually add the adapter. See "Manually adding the Ethernet device drivers with Windows Me" in the following section.

3. Click **Removable Media CD-ROM** option and insert the *IBM Data Migration User's Guide and Software CD* into the CD-ROM drive, if not already inserted. If the CD browser window opens after you insert the CD, close that window.
4. Click **The Updated Driver** and click **Next**.
5. When the files have been copied, click **Finish**, and restart your computer when prompted.
6. Proceed to "Installing the IBM Data Transfer software" on page 1-10.

Manually adding the Ethernet device drivers with Windows Me:

Note: If the Add New Hardware Wizard window does not display, check the Device Manager list to see if the new adapter is present. If it is not, follow these instructions to manually add the adapter.

1. Click **Start**→**Settings**→**Control Panel**.
2. From the Control Panel, double-click the **Add New Hardware** icon.
3. Click **Specify the location of the driver**, and click **Next**.
4. Click **Display a list of all drivers in a specific location...**, and click **Next**.
5. Select **Network Adapter** from the list, and click **Next**.
6. Insert the *IBM Data Migration User's Guide and Software CD* if not already inserted. If a CD browser window automatically starts, close that window.
7. Click **Have Disk**.
8. In the option box below **Copy manufacturer's files from...**, type the path `e:\Drivers\Intel\w9x` where *e* is the drive letter of the CD-ROM.

9. Follow the instructions to install the drivers. When the adapter is added, it appears in the Network adapters list.
10. Click **OK** at the **Select Device** window.
11. The New Hardware Wizard displays the message that it has found the driver. Click **Next**.
12. Click **Finish**.
13. Restart your computer when prompted.
14. Proceed to "Installing the IBM Data Transfer software" on page 1-10

Windows 98

Follow this procedure to install the Ethernet device drivers in Windows 98:

1. After you install the Ethernet adapter in the computer, start the computer. The New Hardware Found window opens.

Note: If this window does not display and Windows 98 starts normally, you might need to manually add the adapter. See "Manually adding the Ethernet device drivers with Windows 98" in the next section.

2. When prompted, insert the *IBM Data Migration User's Guide and Software CD* into the CD-ROM drive, if it is not already inserted. If a browser window automatically starts, close that window.
3. Type the path `e:\Drivers\Intel\w9x` to the device drivers where *e* is the drive letter to the CD ROM drive and click **OK**.
4. Restart the system when prompted.
5. Proceed to "Installing the IBM Data Transfer software" on page 1-10.

Manually adding the Ethernet device drivers with Windows 98:

Note: If the New Hardware Found window does not open, check the Device Manager list to see if the new adapter is present. If not follow these instructions to manually add the adapter.

1. Click **Start**→**Settings**→**Control Panel**.
2. From the Control Panel, double-click the **System** icon.
3. Click the **Device Manager** tab.
4. Double-click **Other Devices** or **Network Adapters** in the list area.
5. Double-click a **PCI Ethernet Controller**.
6. Click the **Driver** tab, then click **Update Driver**.
7. Select **Display a list of all the drivers...** and click **Next**. If not already inserted, insert the *IBM Data Migration User's Guide and Software CD* and click **Have Disk**. If a browser window automatically starts, close that window.
8. In the option box below Copy manufacturer's files from..., type the path `e:\Drivers\Intel\w9x` where *e* is the drive letter of the CD-ROM.
9. Follow the instructions to install the drivers. When the adapter is added, it appears in the Network adapters list.
10. Click **OK** at the Select Device window.
11. The Update Wizard displays the message that it has found the driver; Click **Next**.

12. Click **Finish**.
13. Restart your computer when prompted.
14. Proceed to “Installing the IBM Data Transfer software” on page 1-10.

Windows 95

Have your Windows 95 installation CD or diskettes available; you will be prompted for them when you install the new adapter. Follow this procedure to install the Ethernet device drivers in Windows 95:

1. After you install the Ethernet adapter in the computer, start the computer. Windows 95 detects the adapter as a PCI Ethernet device and the New Hardware Found window opens. Depending on your version of Windows 95, you'll see either the Update Device Driver Wizard or the New Hardware Wizard window.

Note: If the New Hardware Found window does not open and Windows 95 starts normally, you might need to manually add the adapter. See “Manually adding the Ethernet device drivers with Windows 95” in the next section.

2. Insert the *IBM Data Migration User's Guide and Software CD* into the CD-ROM drive, if not already inserted. If a browser window automatically starts, close the window.
3. Follow the on-screen instructions. When prompted, type the path `e:\Drivers\Intel\w9x` where *e* is the letter of your CD-ROM drive.
4. Click **OK**.
5. Follow the instructions to install the drivers. When the adapter is added, it is shown in the Network adapters list.
6. Follow the prompts for any Windows 95 installation disks and restart the computer when prompted.
7. Proceed to “Installing the IBM Data Transfer software” on page 1-10.

Manually adding the Ethernet device drivers with Windows 95

Note: If the New Hardware Found window does not open at startup and you cannot connect the computer to the network, check the Device Manager list to see if the new adapter is present. If it is not, follow these steps to manually add an adapter.

1. Click **Start**→**Settings**→**Control Panel**.
2. From the Control Panel, double-click the **System** icon.
3. Click the **Device Manager** tab.
4. Double-click **Other Devices** (question mark icon) in the list area.
5. Double-click a **PCI Ethernet Controller**.
6. Click the **Driver** tab, then click **Update Driver**.
7. Insert the *IBM Data Migration User's Guide and Software CD*, if not already inserted. If a browser window automatically starts, close that window.
8. At the Update Device Driver Wizard, select **No** and click **Next**.

9. Click **Have Disk**.
10. At the Select Device window, type the path `e:\Drivers\Intel\w9x` where *e* is the CD-ROM drive letter. Click **OK**.
11. Follow the instructions to install the device drivers. When the adapter is added, it appears in the Network adapters list.
12. Follow any prompts for Windows 95 installation disks and restart when prompted.
13. Proceed to “Installing the IBM Data Transfer software” on page 1-10.

Installing the Ethernet adapter in a mobile computer (Mobile with PC Card Kit)

If your previous computer is a mobile computer without an Ethernet adapter, you will need to install the Ethernet PC Card adapter that came with your kit (you should have purchased the Mobile with PC Card Kit).

Follow the instructions in the next section to install the Ethernet PC Card adapter.

Installing the Ethernet PC Card with Windows 2000, Windows Me, Windows 98 and Windows 95

1. Connect the converter cable to the Ethernet PC Card adapter as shown in the following illustration:

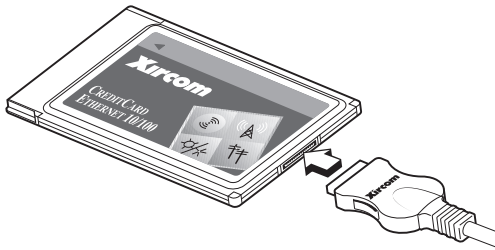

2. Turn on your computer if it is not already on and wait for Windows to start.
3. Insert the Ethernet PC Card into an available PC Card slot in your mobile computer, as shown in the following illustration.



If you are unsure about the location of the PC Card slot, refer to your mobile computer user's guide.

4. Install the device drivers for the Ethernet PC Card adapter.

- If your previous computer is running Windows 2000, Windows Me, or Windows 98 SE, the Ethernet PC Card will automatically be recognized and the device drivers will be loaded. If prompted, restart the computer. Proceed to “Installing the IBM Data Transfer software”
- If your previous computer is running Windows 98 or Windows 95, follow the instructions for your operating system below.

Windows 98

1. If not already running, start Windows 98. The Add New Hardware Wizard opens.
2. Insert the *IBM Data Migration User's Guide and Software CD* if not already inserted. If a browser window automatically starts, close the window.
3. Click **Next**.
4. Click **Search for the best driver**, and click **Next**.
5. Click **CD-ROM drive**, and click **Next**.
6. Click **Next** again to install the driver displayed.
7. Click **Finish**.
8. Restart the computer.
9. Proceed to “Installing the IBM Data Transfer software”.

Windows 95

1. If not already running, start Windows 95. The Update Device Driver Wizard opens.
2. Insert the *IBM Data Migration User's Guide and Software CD* if not already inserted. If a browser window automatically starts, close that window
3. Click **Next**. I.
4. Accept the detected device driver and click **Finish**. If prompted for additional files, click **OK**.
5. Type the path *e:\Drivers\Xircom* where *e* is the drive letter of your CD-ROM drive.
6. Click **Yes** if prompted to restart.
7. Proceed to “Installing the IBM Data Transfer software”.

Installing the IBM Data Transfer software

Use the IBM Data Transfer program to perform the actual transfer of data. Install the software after the Ethernet adapter is installed in the previous computer.

- The software must be installed on your previous and new computer.
- Follow the instructions in this section to install the IBM Data Transfer software first on your previous computer and then on your new computer.

Installing the IBM Data Transfer software on the previous computer

Follow this procedure to install the IBM Data Transfer software on the previous computer.

1. If your new computer is running Windows 2000, log on to your previous computer using the same user name and password as you are logged on to your new computer with. If your previous computer is running Windows 2000, that user name must be part of the Administrators group on your previous computer.

Note: For more information about logging onto Windows, changing user passwords, or verifying whether a user is part of the Administrators group, see “Appendix C. Troubleshooting, hints and tips” on page C-1.

2. Insert the *IBM Data Migration User’s Guide and Software CD* into the CD or DVD drive in your previous computer.
3. If your browser window does not automatically open, click **Start→Run** and type `e:\launch.htm` where *e* is the CD or DVD Drive. Select or click your language on the language browser page.
4. On the left side of the browser page, click **Install IBM Data Transfer Application** to start the automated InstallShield program for IBM Data Transfer.
5. The InstallShield Wizard window opens. Click **Next**.

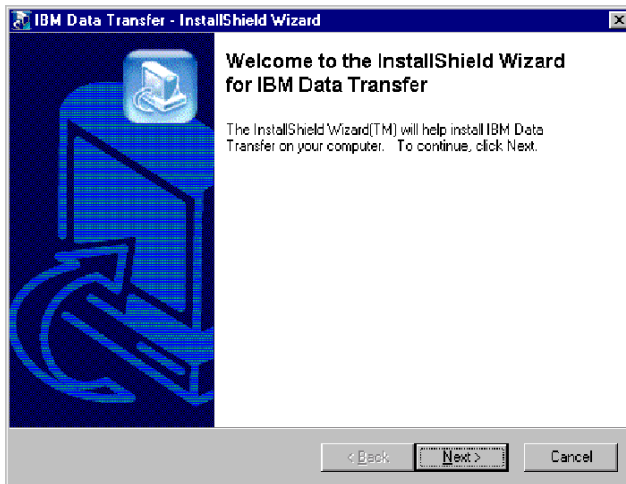

6. In the Setup Configuration window, select **Previous Computer** and click **Next**.

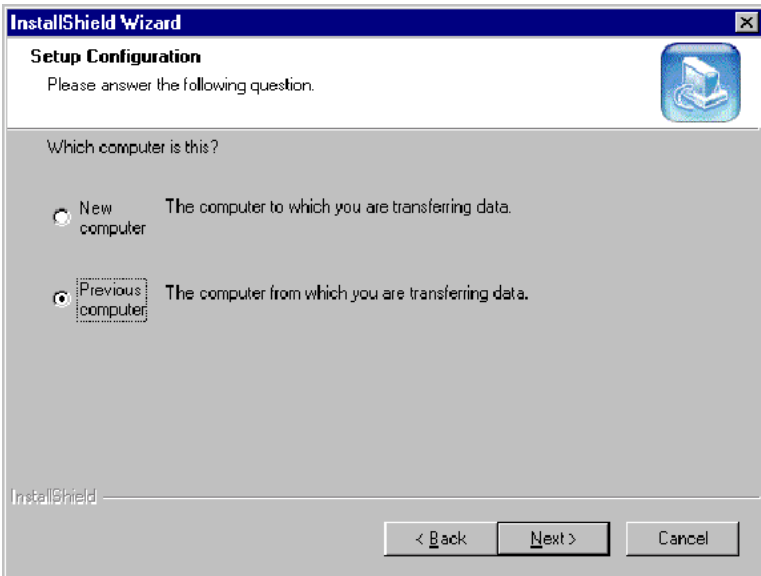

7. In the Setup Configuration window, select **I already have the IBM Data Transfer program installed**, and click **Next**.

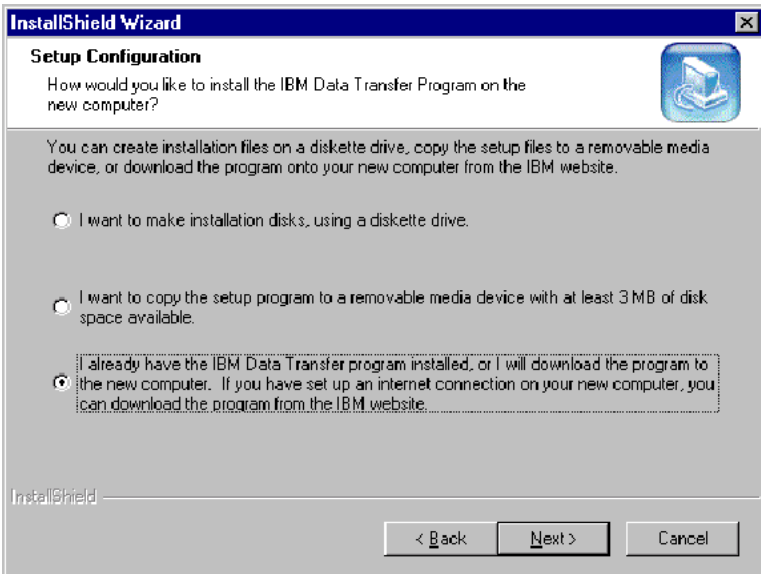

8. In the Choose Destination Location window, accept the default folder, and click **Next**.

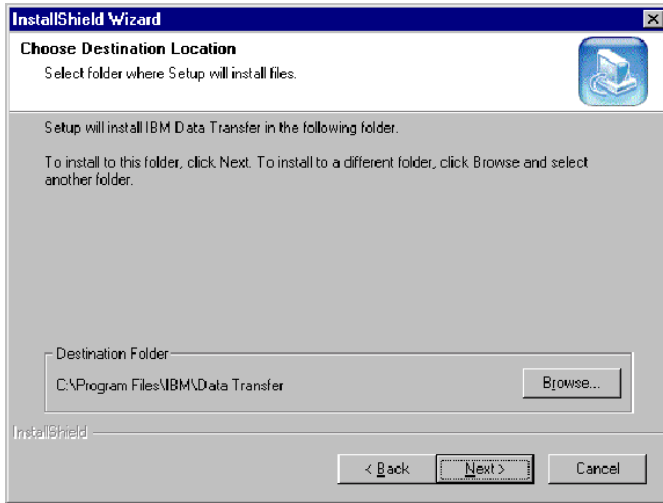

9. In the Select Program Folder window click **Next**. The program is then installed to your previous computer

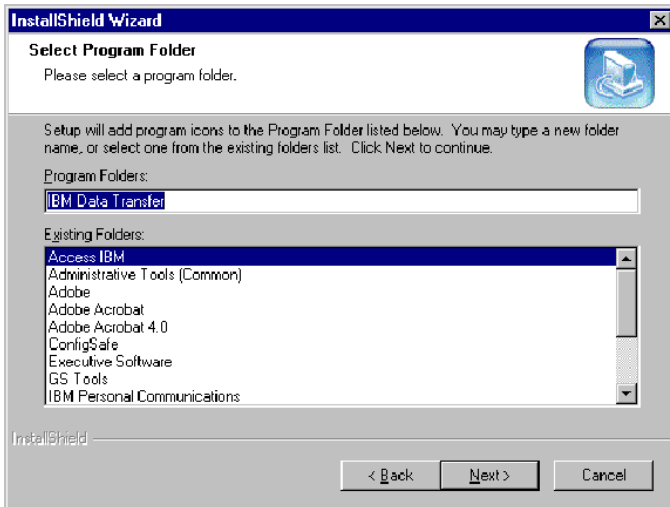

10. In the InstallShield Wizard Complete window, ensure the **Start IBM Data Transfer now** check box is selected, and then click **Finish**.
 - The IBM Data Transfer Software should start automatically.
 - Proceed to the next section, “Installing the IBM Data Transfer software on the new computer”.

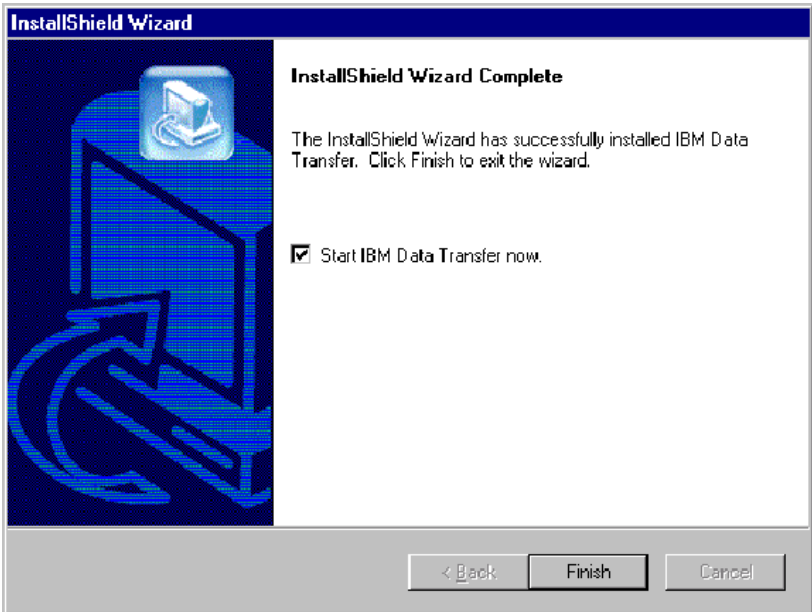

Installing the IBM Data Transfer software on the new computer

Follow this procedure to install the IBM Data Transfer software on the new computer.

1. If your new computer is running Windows 2000, you must log on to your new computer with a user name that is part of the Administrators group.

Note: For information on logging onto Windows and checking whether a user name is part of the Administrators group see “Appendix C. Troubleshooting, hints and tips” on page C-1.

2. Insert the *IBM Data Migration User’s Guide and Software CD* into the CD or DVD drive in your previous computer.
3. If your browser window does not automatically open, click **Start→Run** and type *e:\launch.htm* where *e* is the CD or DVD Drive. Select or click your language on the language browser page.

4. On the left side of the browser page, click **Install IBM Data Transfer Application** to start the automated InstallShield program for IBM Data Transfer.
5. The InstallShield Wizard window opens. Click **Next**.

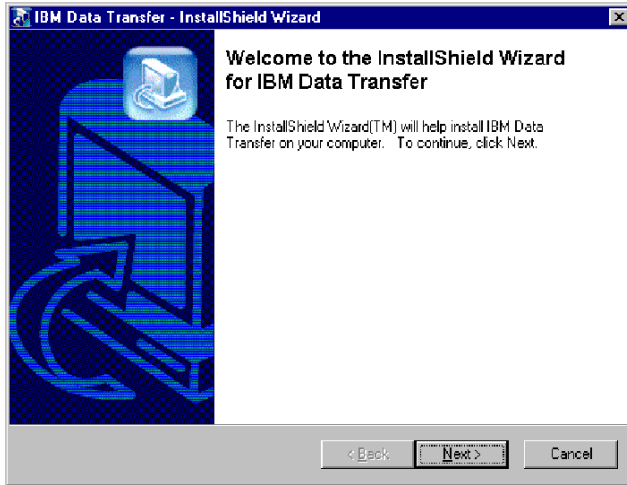

6. In the Setup Configuration window, select **New Computer**, and click **Next**.

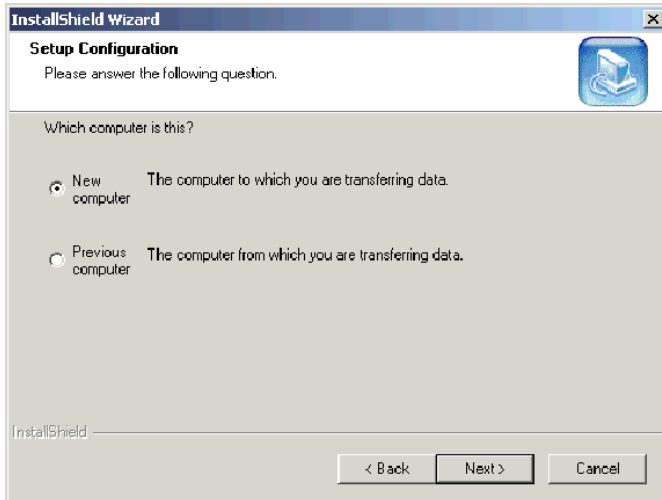

7. In the Setup Configuration window, select **I already have the IBM Data Transfer program installed**, and click **Next**.

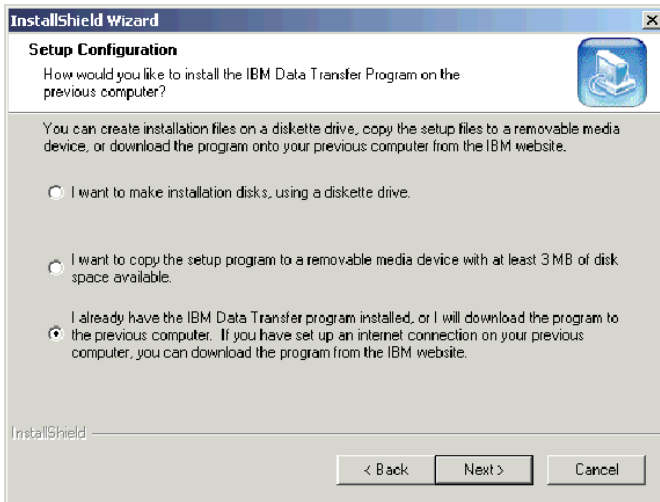

8. In the Choose Destination Location window, accept the default folder, and click **Next**.

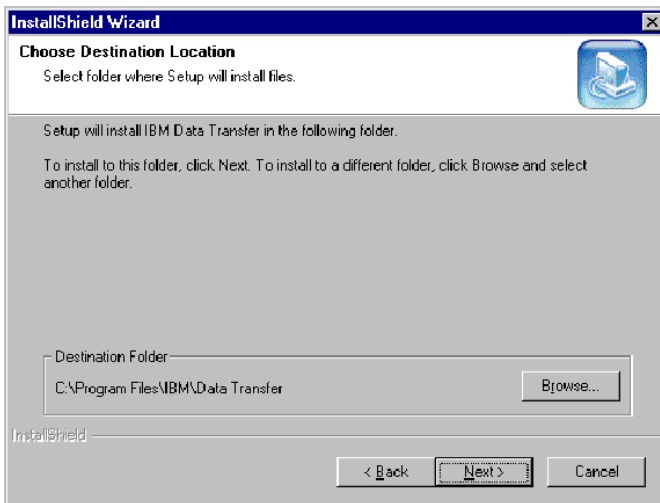

9. In the Select Program Folder window, accept the default folder and click **Next**. The program is then installed on your computer.

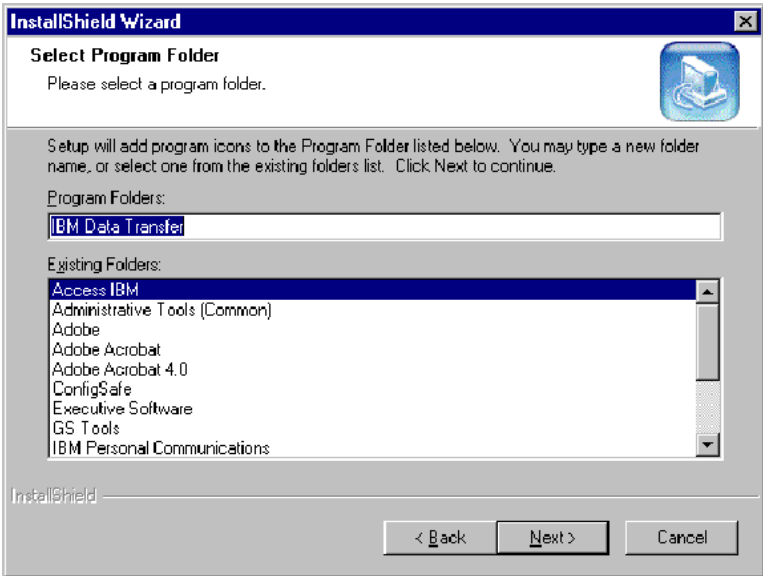

10. In the InstallShield Wizard Complete window, ensure that the **Start IBM Data Transfer now** check box is selected, and then click **Finish**.
- The IBM Data Transfer software starts automatically.
 - Proceed to the next section, “Performing the data migration” on page 1-19.

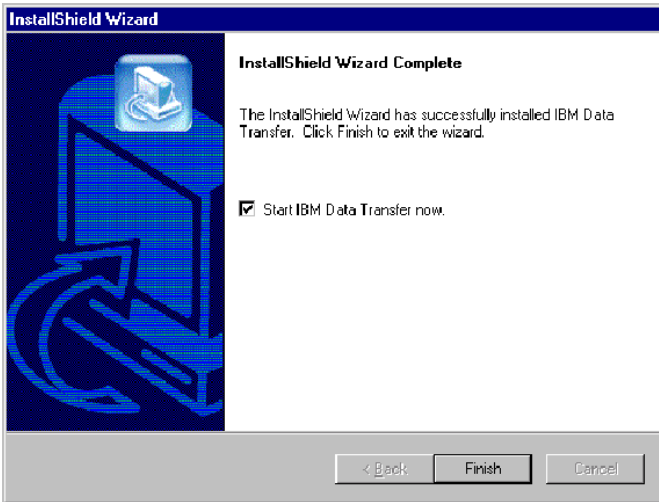

Performing the data migration

After you have installed the Ethernet adapter in your previous computer and the IBM Data Transfer software on both computers, you are now ready to perform the migration. You will need to connect the Ethernet ports on the two computers using the crossover cable, included in the kit.

Follow these steps to connect the two computers.

1. Insert the connector from one end of the crossover cable into the Ethernet port of your previous computer.

Note: If you installed the Ethernet PC Card adapter in your mobile computer, you will need to insert the connector on the crossover cable to the free end of the converter cable, connected to PC Card. See the following illustration.

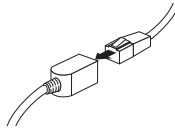

2. Insert the connector on the opposite end of the cable to the Ethernet port of your new computer.

The following illustration provides an example of two computers connected.

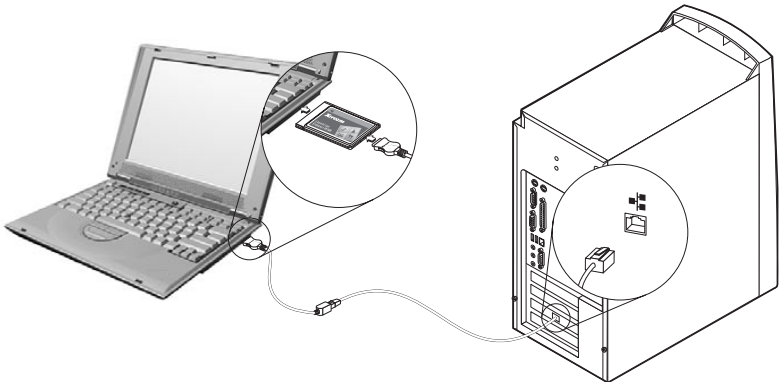

Note: This illustration below represents a unique configuration. Your configuration might vary. For example, you may have two mobile computers or two desktops. The PCI or PC Card slots and ethernet ports might be in a different location.

Begin transfer process on the new computer

Ensure you begin the transfer process on the new computer. Follow this procedure for the data transfer process:

Note: You might need the original disks or CD that came with your operating system.

1. If your new computer is running Windows 2000, you must log on to your new computer with a user name that is part of the Administrators group if you have not already done so.

Note: For information on logging onto Windows and checking whether a user name is part of the Administrators group see “Appendix C. Troubleshooting, hints and tips” on page C-1.

2. If it is not already running, start the IBM Data Transfer application on your *new* computer by clicking **Start→Programs→IBM Data Transfer→IBM Data Transfer**.
3. In the following window, click **Next**.

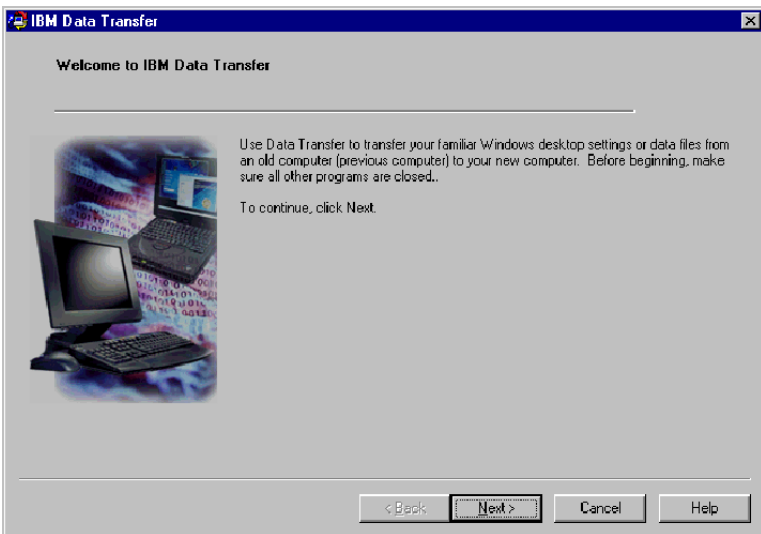

4. On the next window, select **New Computer** and click **Next**.

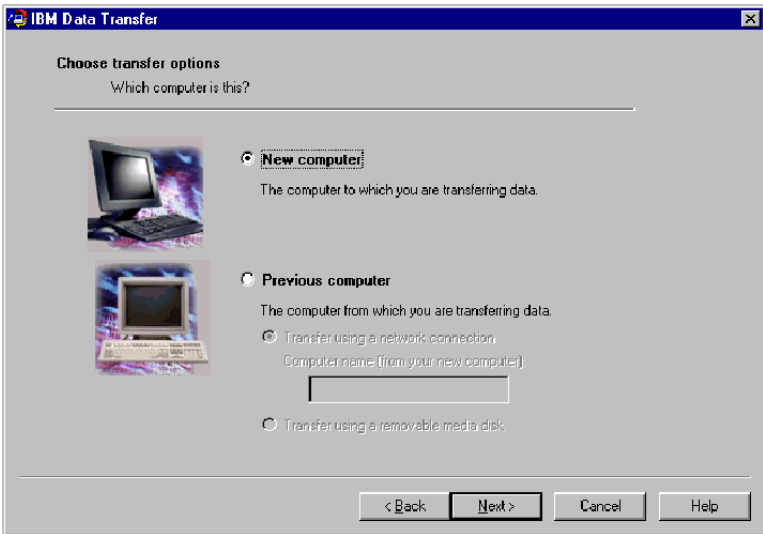

5. On the next window, choose your transfer options, selecting the settings you want to transfer. Read the description below each selection for information on what will be transferred. For each item selected, a window will open with additional information about transferring that selection.
- If Windows desktop settings is selected, the following window will open. Please note that Internet bookmarks will only be copied if both computers have Active Desktop support. Click **OK**.

Note: To check whether you have Active Desktop installed, right-click on your computer desktop. If Active Desktop is installed, it is displayed in the right-click menu.

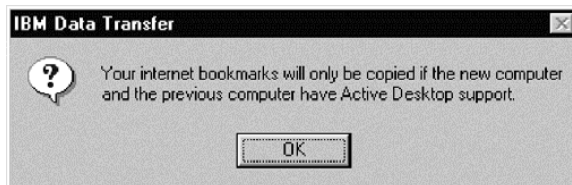

- If Network settings is selected, the following window will open. Please note that if network settings are transferred, the computers cannot be connected to the network at the same time without changing the TCP/IP address and machine name of the previous computer. Click **OK**.

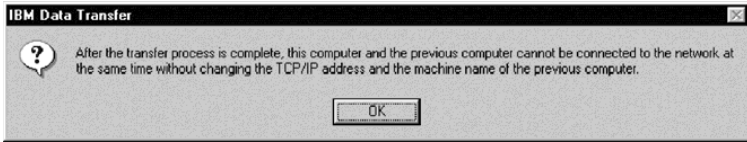

- If Folder contents is selected, the following window will open. Please note that any files that are transferred from the old computer will replace any files on the new computer that have the same name and same path. For example, if you transfer a folder with the path C:\Pictures that contains the file, picture1.bmp, on your previous computer and your new computer already has a file with the path C:\Pictures\picture1.bmp, then the picture1.bmp file on your new computer will be replaced by the picture1.bmp file from your previous computer.

If you transfer the folder C:\Pictures from your previous machine and you already have a folder C:\Pictures on your new machine, the contents of the Pictures folder from you previous machine will be added to the contents of the Pictures folders on your new machine. Since this kit is meant to be used to transfer data to a brand new IBM computer, you should not have any data files already on the new computer that would be overwritten by data files from your previous machine.

Note: You will be prompted to choose which folders you want to transfer in step 20.



Click Next after you have made your selections.

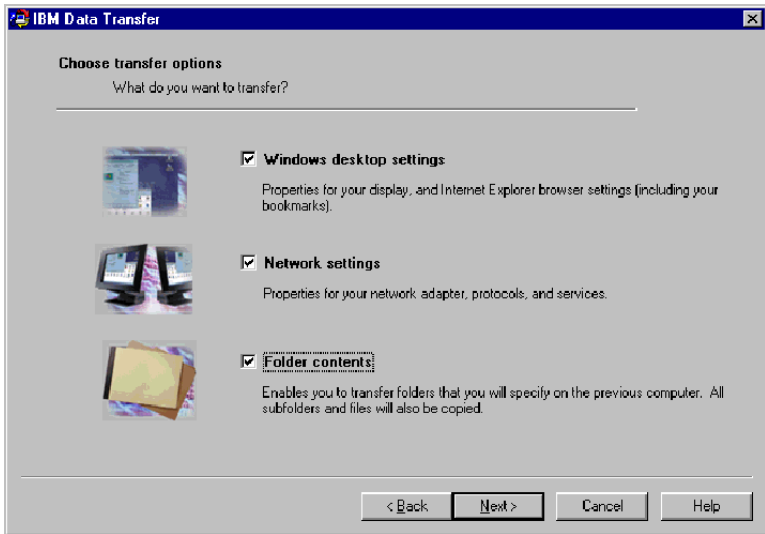

6. In the next window, select **Across a network connection**. Click Next.

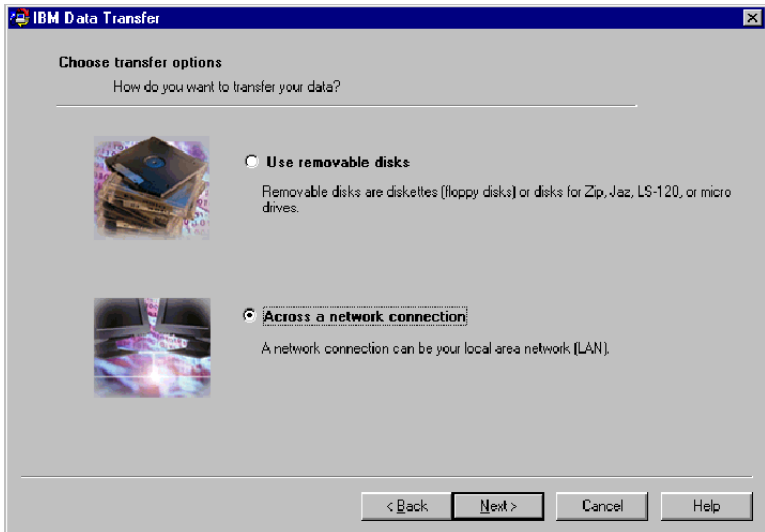

7. The following window displays the items you have selected to transfer. Click Next.

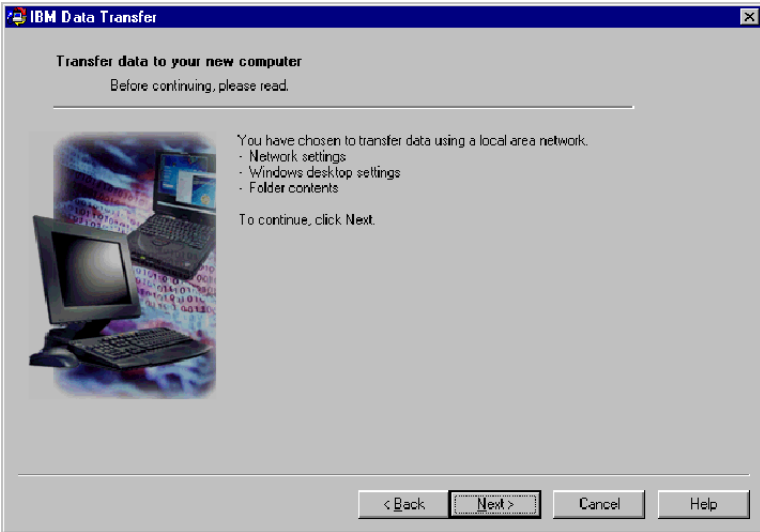

8. If not already installed, network support will need to be added to your new computer. Use the following instructions for the operating system on your new computer, to check and add network support.

Windows 2000

- a. The Network and Dial-up Connections window opens.

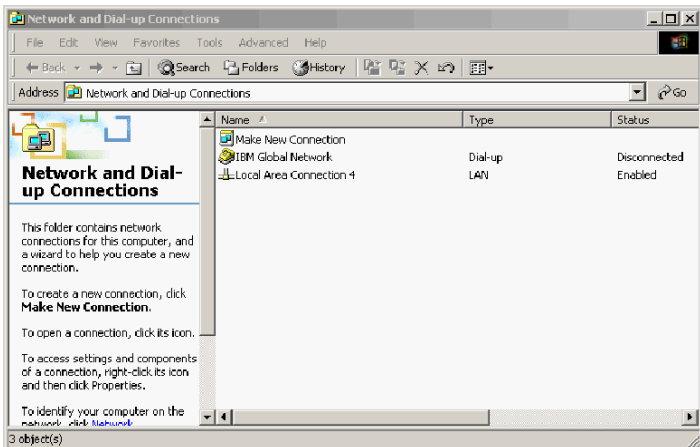

- b. Depending on your current network settings, one of the following three Configure settings windows will open. Follow the instructions in

the Configure settings window to set up NetBEUI and File and Print Sharing for Microsoft Networks on your new computer.

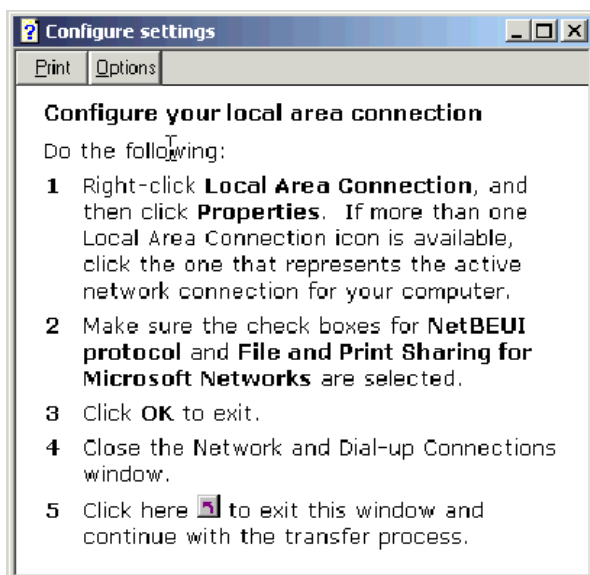

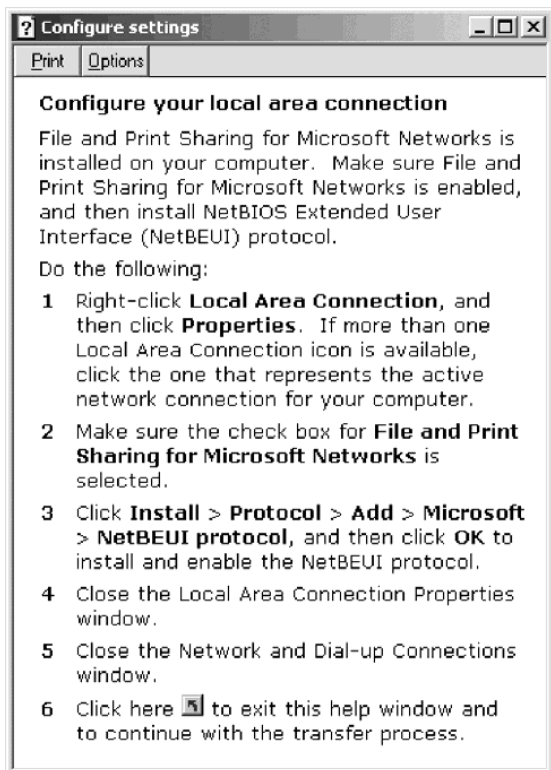

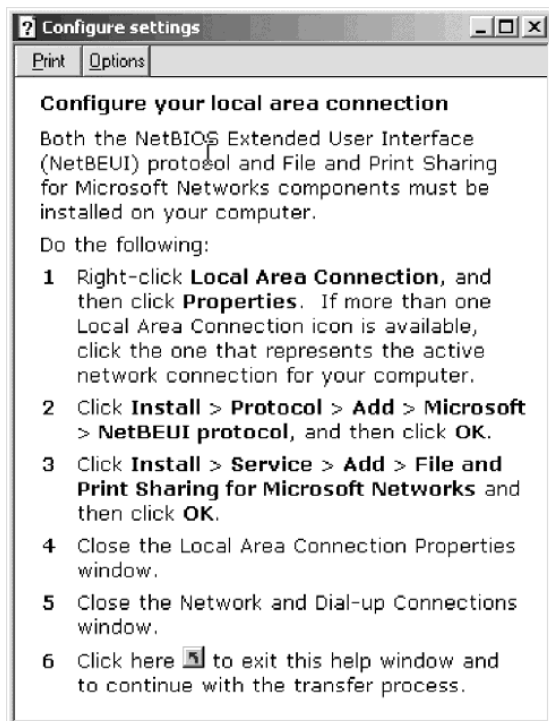

Windows 95, Windows 98, and Windows Me

- a. If network support needs to be installed on your new computer, you will see the following window open.

Note: If you don't see this window, proceed to step 9. Network support is already installed.

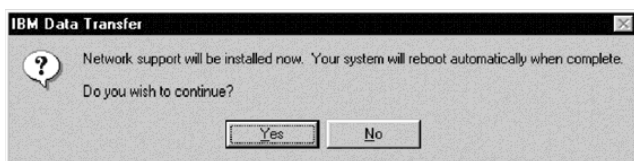

- b. Click **OK** and network support will be installed. Click **OK** to restart the computer when prompted.

Note: When Windows is installing network support, you may be prompted to insert your operating system disk. If so, insert the operating system disk and click **OK**.

Note: When Windows is installing network support, you may see several Version Conflict windows. If any of these windows open, click **Yes** on each window to keep the existing file.

- c. When Windows restarts, this window opens. Click **Next**. Proceed to Step 9.

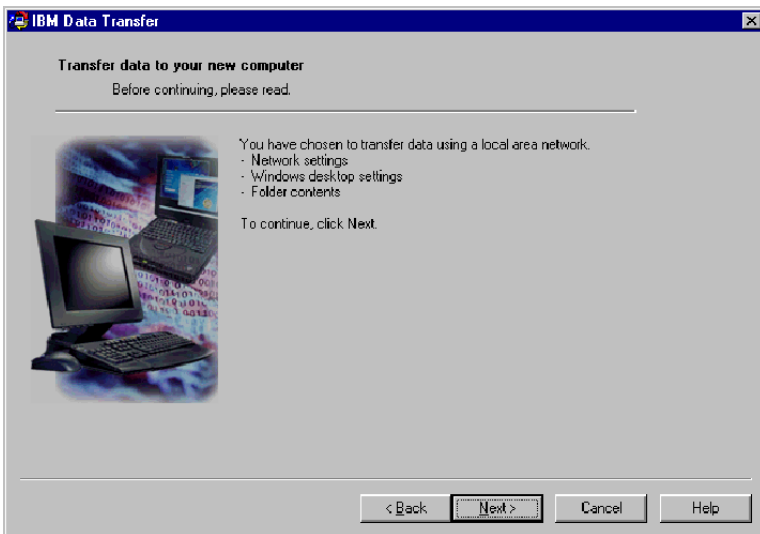

9. A window will open that displays the name of the new computer. Write down the name exactly as shown. You will be prompted for it on the previous computer setup. Click **OK**.

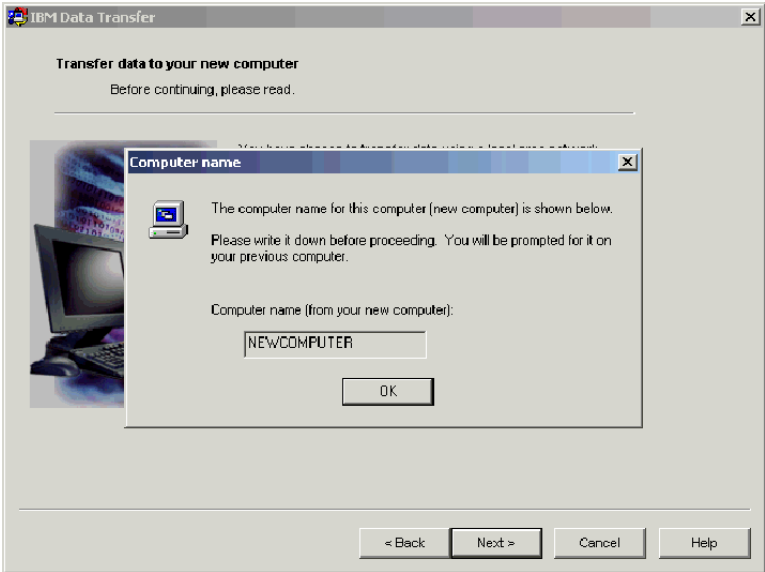

10. Follow the instructions that are shown in the following window. Do not click **Next** until you have completed the steps on this window for your previous computer.

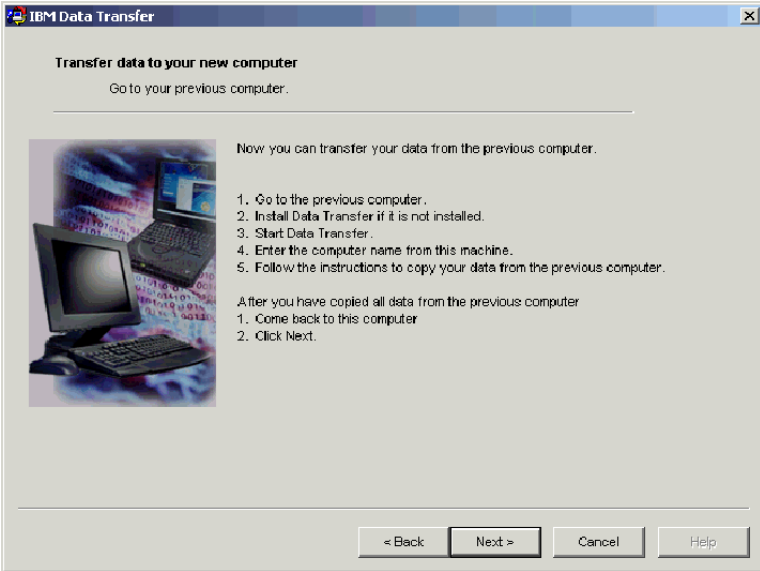

11. Go to your previous computer to continue the transfer process.

Note: You might need the original disk that came with your operating system.

12. If your new computer is running Windows 2000 and you have not already done so, log on to your previous computer using the same user name and password as you are logged on to your new computer with. If your previous computer is running Windows 2000, that user name must be part of the Administrators group on your previous computer.

Note: For more information about logging onto Windows, changing user passwords, or verifying whether a user is part of the Administrators group, see "Appendix C. Troubleshooting, hints and tips" on page C-1.

13. If it is not already running, start the IBM Data Transfer application on your previous computer. To start, click **Start→Programs→IBM Data Transfer→IBM Data Transfer**.

14. In this entry window, click **Next**.

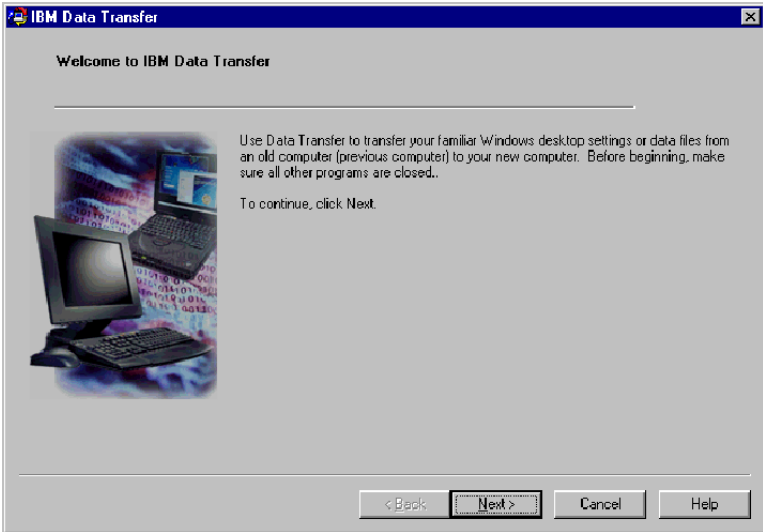

15. In the Choose Transfer Options window, select the **Previous Computer** radio button. Select the **Transfer using a network connection** radio button. Type in the computer name of the new computer (you should have this written this down from the new computer), and click **Next**.

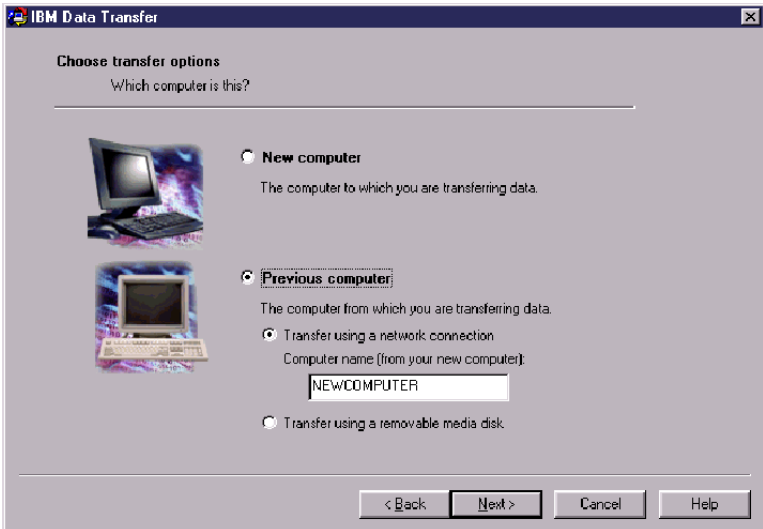

16. If not already installed, network support will need to be added to your previous computer. To check and add network support, follow the instructions below, underneath the operating system on your previous computer.

Windows 2000

- a. The Network and Dial-up Connections window opens.

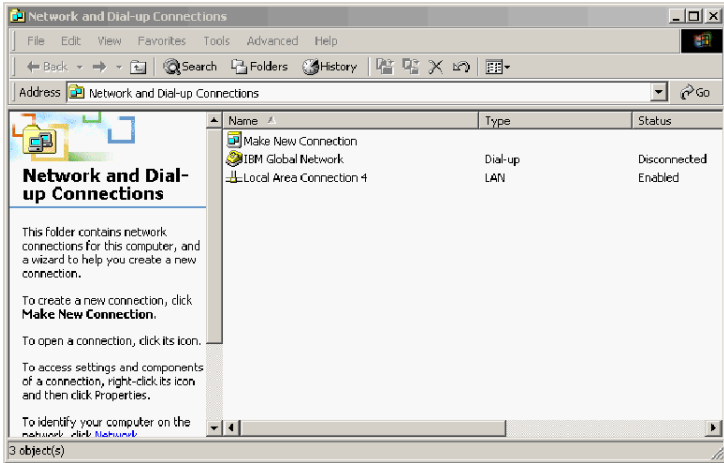

- b. Depending on your current network settings, one of the following three Configure settings windows will open. Follow the instructions in the Configure settings window to set up Net BEUI and File and Print Sharing for Microsoft Networks on your previous computer. When finished, proceed to step 19.

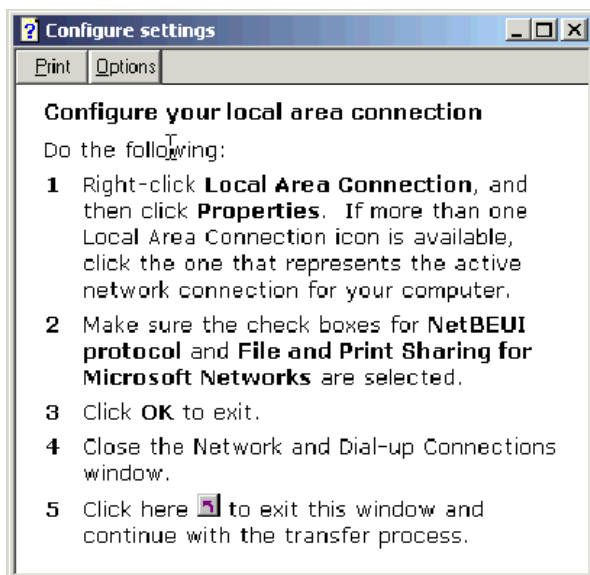

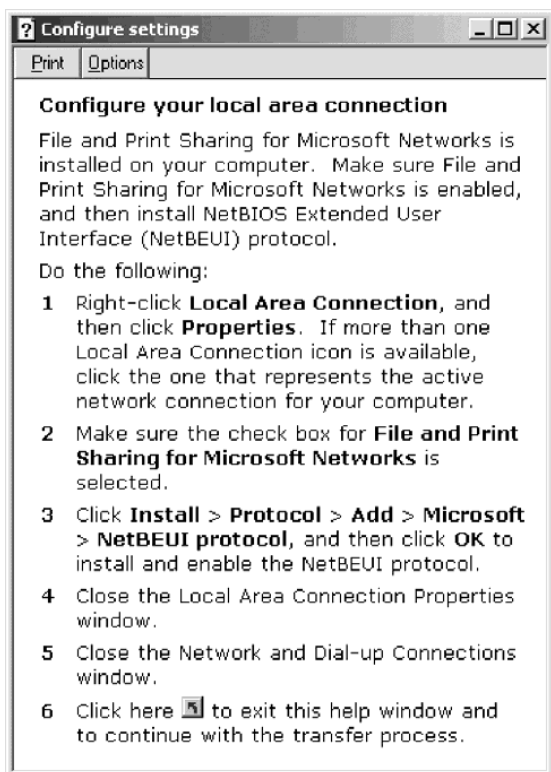

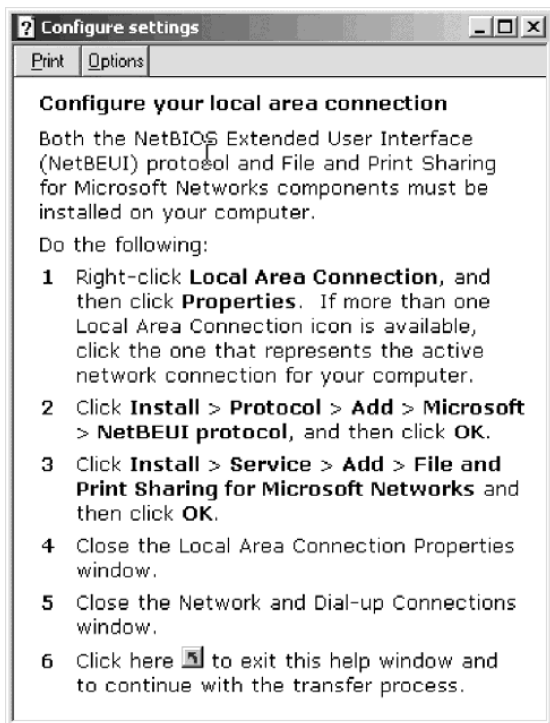

Windows 95, Windows 98 and Windows Me

- a. If network support needs to be installed on your new computer, you will see the following window open.

Note: If you don't see this window, proceed to step 19. Network support is already installed.

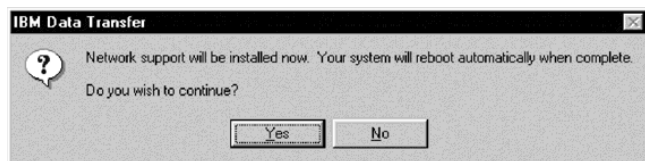

- b. Click **OK** and network support will be installed. Click **OK** to restart the computer when prompted. Proceed to step 17.

Note: When Windows is installing network support, you may be prompted to insert your operating system disk. If so, insert the operating system disk and click **OK**.

Note: When Windows is installing Network support, you may see several Version Conflict windows. If any of these windows open, click **Yes** on each one to keep the existing file.

17. When Windows restarts, the application takes you back to this window. Click **Next**.

Note: If this window does not display when Windows restarts and you see the window asking for the name of the new computer, skip to step 18.

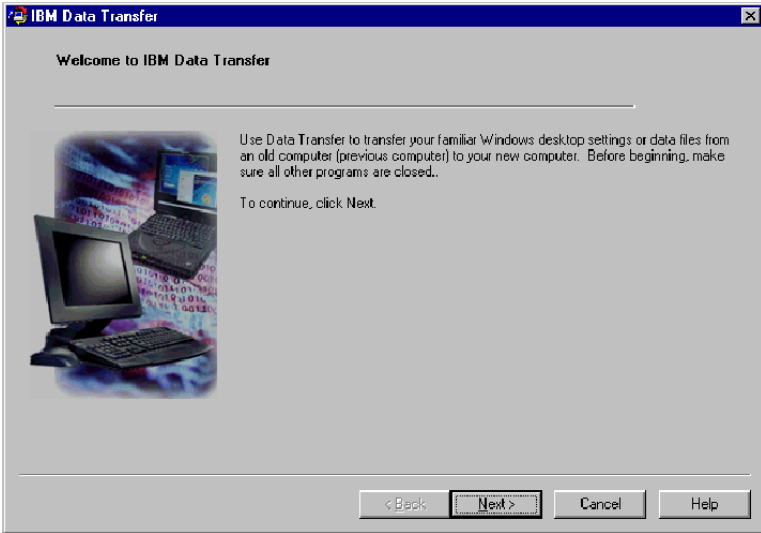

18. In the Choose Transfer Options window, make sure the **Previous Computer** radio button is selected. If not already selected, click the radio button for **Transfer using a network connection**. Type in the name of the new computer (you should have written this down from the new

computer) and click Next.

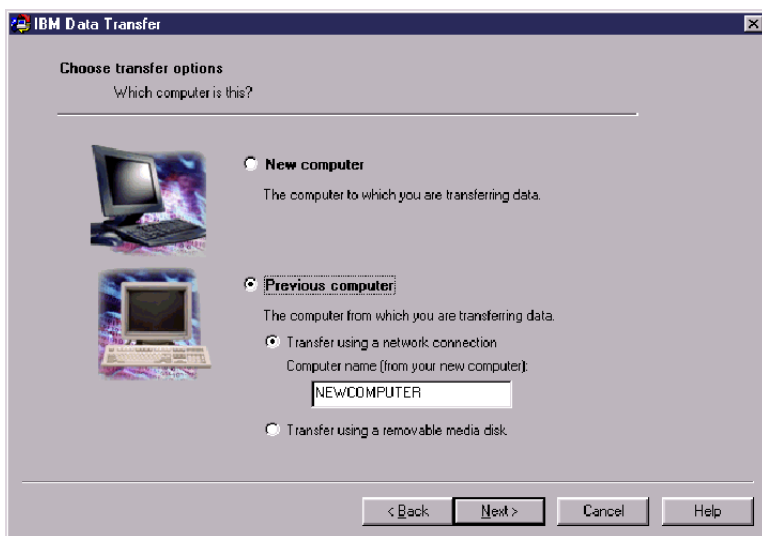

19. A window will display what items you have selected to transfer. Click **Next**.

Note: If the following window does not display and an error window opens, your previous computer cannot connect to your new computer. Follow the instructions in the error window to correct the connection problem. For more information on specific error troubleshooting tips, see "Appendix C. Troubleshooting, hints and tips" on page C-1

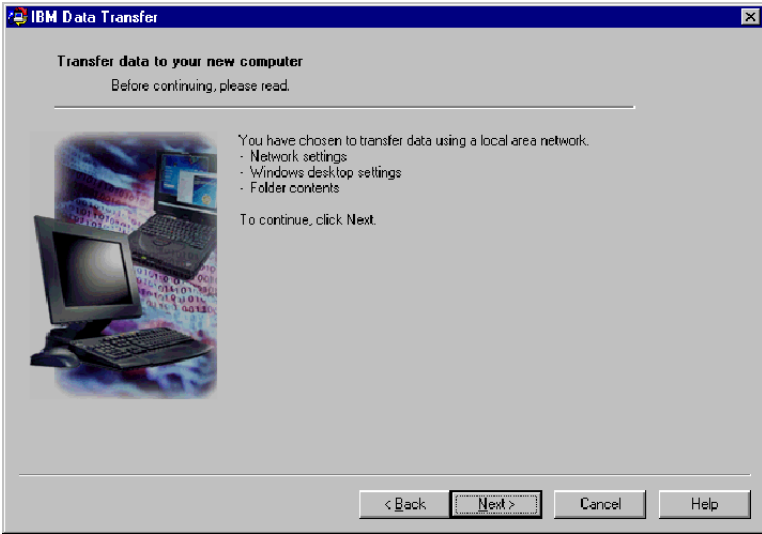

20. The next window allows you to select the folders that will be transferred. Type a folder path in the first box and click **Add** or click **Browse** to look for the folders.

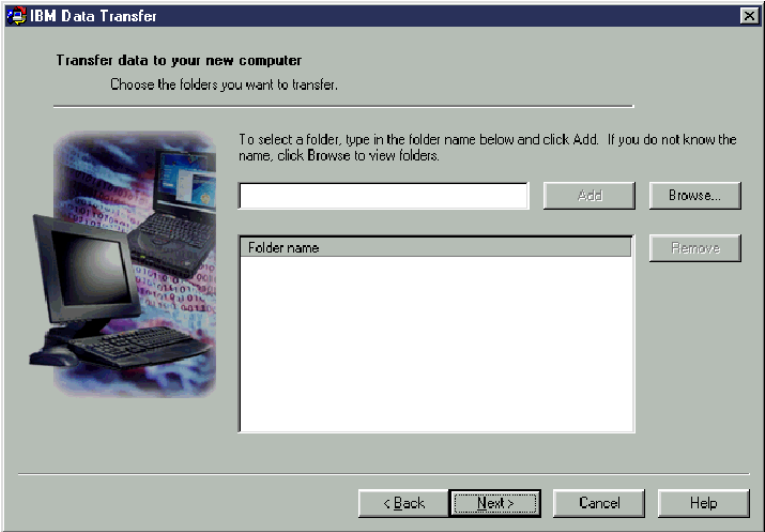

21. If you clicked **Browse**, a window will display to allow you to select a folder to be transferred. Select a folder and click **OK**. Repeat for additional folders you want to transfer. For each folder selected, all files and subfolders under that folder will be transferred.

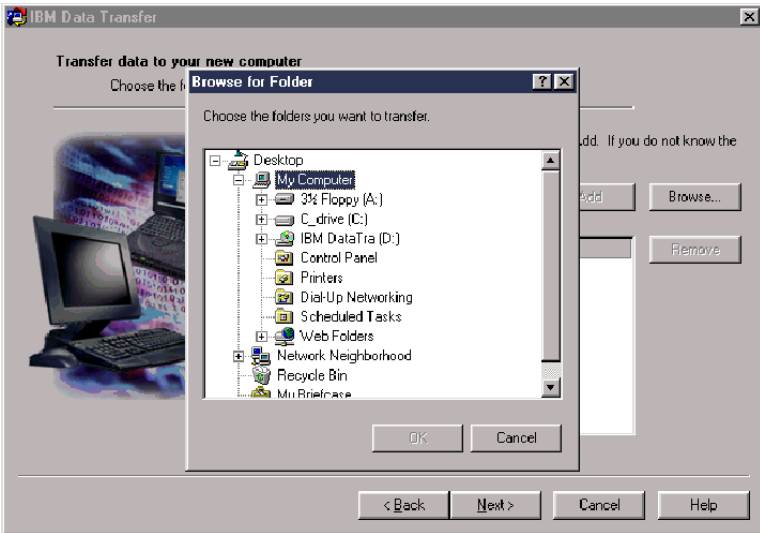

22. The program will add each folder to the bottom box. When finished selecting all folders to transfer, click **Next**.

Note: The IBM Data Transfer software cannot be used to migrate software applications, only data files.

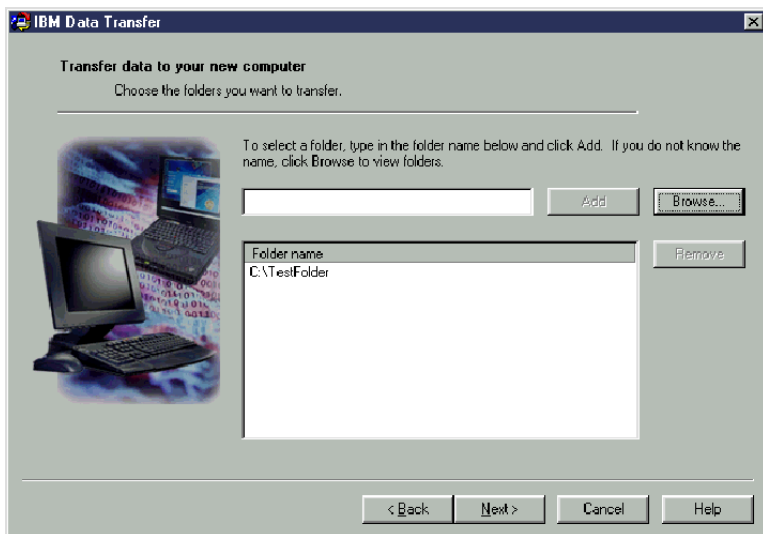

23. On the next window, click **Next**.

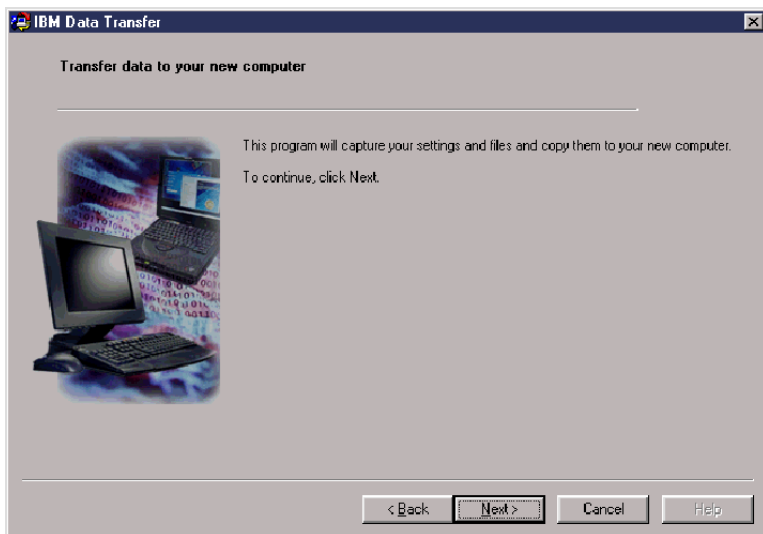

24. In the window **Gathering data. Please wait**, the program will begin the transfer. This process could take a while, depending on how much data is being transferred. Let the process run and do not run other programs while it is processing.

Note: Your previous computer must have free hard drive space equal to the amount of data that will be transferred at one time. If you want to transfer larger quantities of data, you could perform several transfers. To check hard drive free space, double-click the **My Computer** icon, right click on the hard drive and select **Properties**. The hard drive Properties window displays the amount of free space.

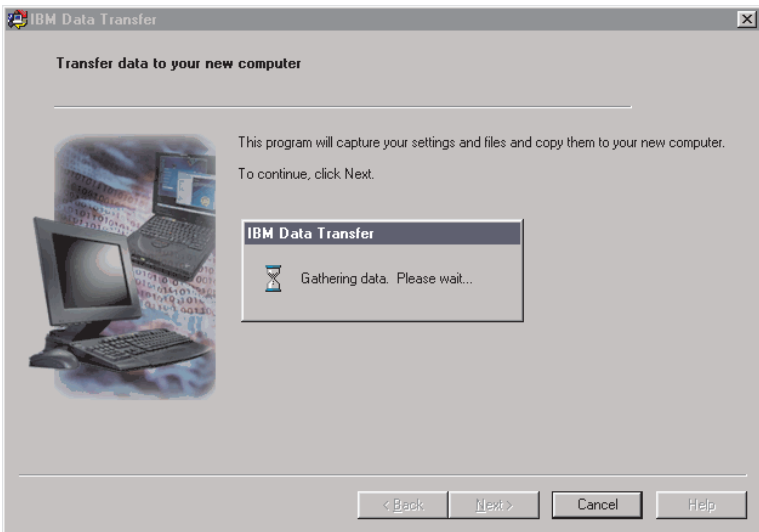

25. Once this part of the transfer process is complete, a new window will display. Click **Finish**. This will restart your previous computer. When the computer restarts, disconnect the crossover cable from the Ethernet port on the previous computer.

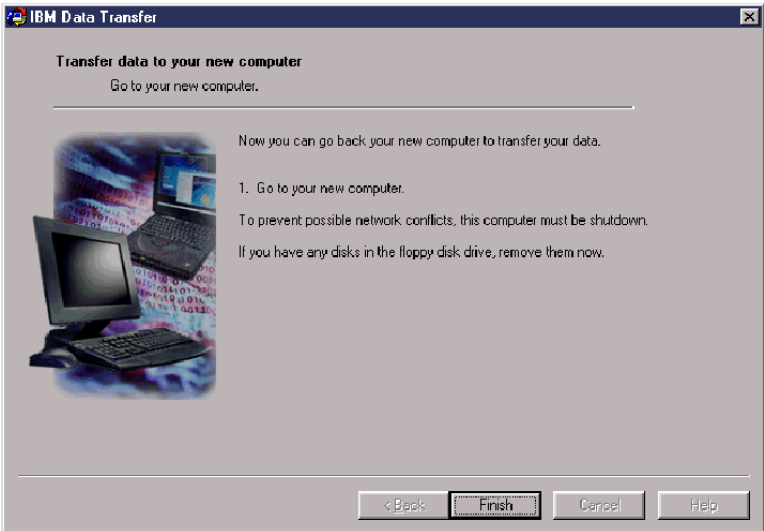

26. Move back to the new computer. The following window should still be open. Click **Next** to proceed with the transfer process.

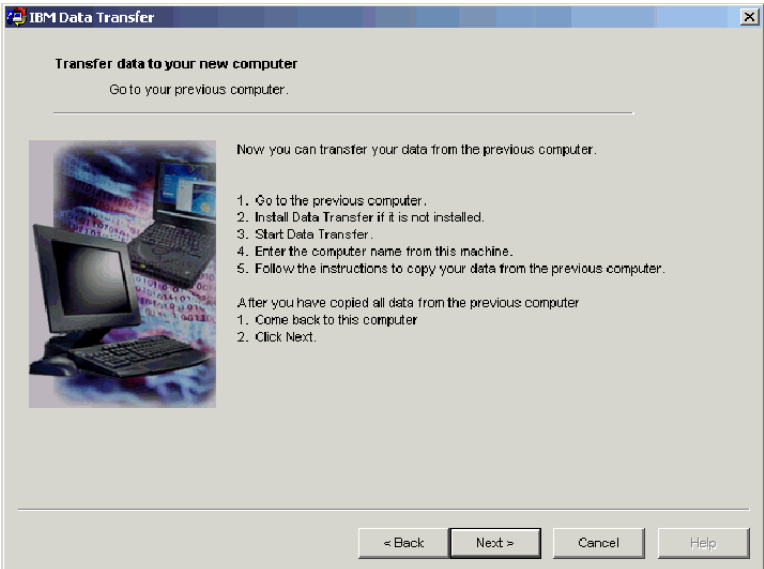

27. Click Next on the following window.

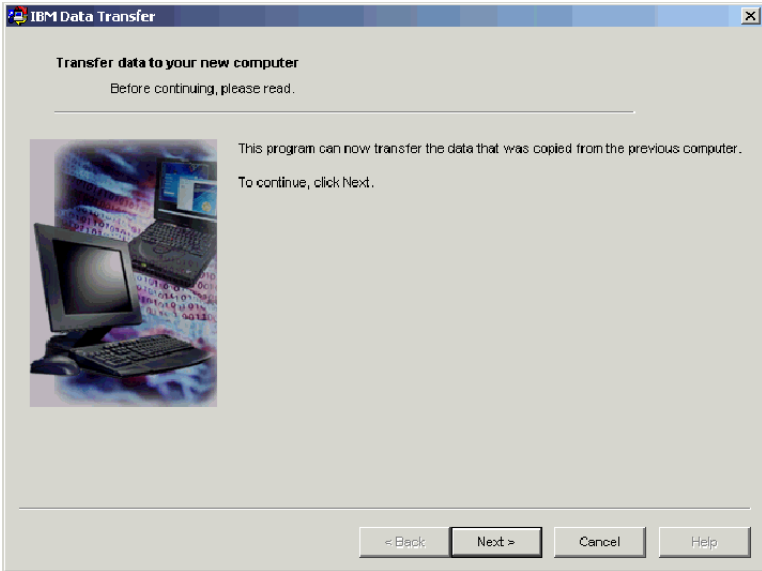

28. A window with a box will display **Copying data. Please wait.** The program will finish the transfer. This process could take a while, depending on how much data is being transferred. Do not run other programs while it is processing.

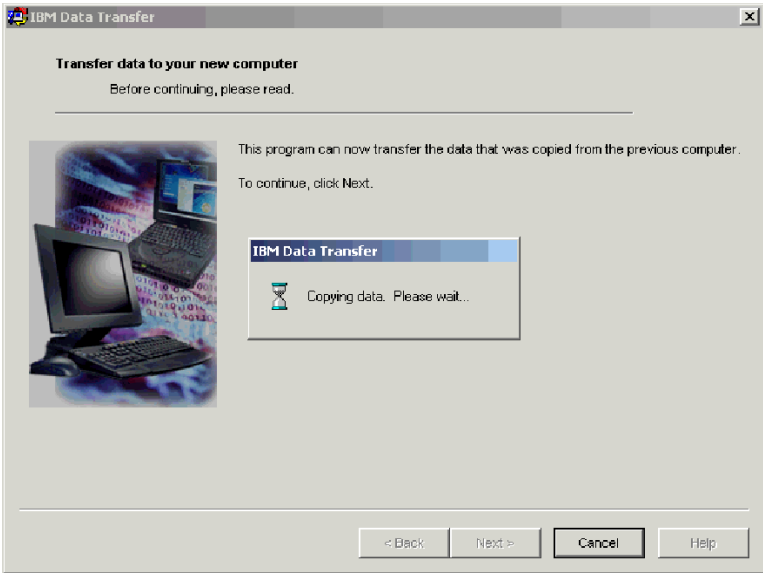

29. When the transfer is complete, the following window displays. Click **Finish**. The new computer will restart.

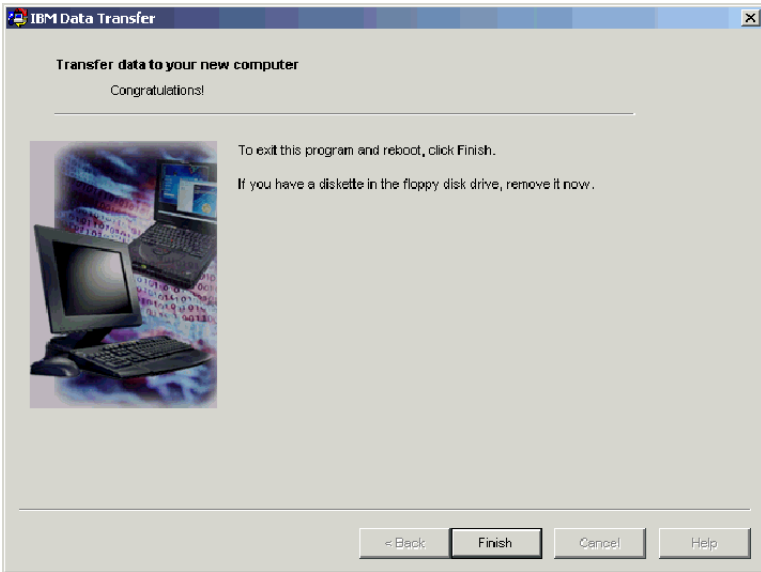

30. Check to make sure that file and print sharing are disabled. Disable them if they are not. For more information on how to check and disable file and print sharing see "Appendix C. Troubleshooting, hints and tips" on page C-1.

All of your data and settings should be transferred. Any folders that were selected to be transferred on the previous computer have been placed in the same path on the new computer.

For example, if you transferred the folder `C:\My Documents\Pictures` from your previous computer, the contents of Pictures will be placed in the `C:\My Documents\Pictures` folder on the new computer.

If the Pictures folder didn't already exist on the new computer, it would have been created during the transfer. If you transfer a folder from any drive on the previous computer, the folder will be placed in the same path on the C: drive on the previous computer. For example, if you transferred the folder `"D:\Temp\Apps"` from your previous computer, the contents of the "Apps" folder would have been placed in the `"C:\Temp\Apps"` folder on the new computer.

Appendix A. Help and service information

This section contains information on how to obtain warranty information on the World Wide Web and online and telephone technical support.

Warranty information on the World Wide Web

The IBM Machine Warranties Web site at http://www.ibm.com/servers/support/machine_warranties/ contains a worldwide overview of the IBM Limited Warranty for IBM Machines, a glossary of terms used in the Statement of Limited Warranty, Frequently Asked Questions (FAQ), and links to Product Support Web pages. The IBM Statement of Limited Warranty is available from this Web site in 29 languages in Portable Document Format (PDF).

Online technical support

Online technical support is available during the life of your product. Online assistance can be obtained through the Personal Computing Support Web site and the IBM Automated Fax System.

<i>Online technical support</i>	
IBM Personal Computing Support Web site	http://www.ibm.com/pc/support
IBM Automated Fax System	1-800-426-3395 (U.S. and Canada)

During the warranty period, assistance for replacement or exchange of defective components is available. In addition, if your IBM option is installed in an IBM computer, you might be entitled to service at your location. Your technical support representative can help you determine the best alternative.

Telephone technical support

Installation and configuration support through the HelpCenter will be withdrawn or made available for a fee, at IBM's discretion, 90 days after the option has been withdrawn from marketing. Additional support offerings, including step-by-step installation assistance, are available for a nominal fee.

To assist the technical support representative, have available as much of the following information as possible:

- Option name
- Option number
- Proof of purchase

- Computer manufacturer, model, serial number (if IBM), and manual
- Exact wording of the error message (if any)
- Description of the problem
- Hardware and software configuration information for your system

If possible, be at your computer. Your technical support representative might want to walk you through the problem during the call.

For the support telephone number and support hours by country, refer to the following table. If the number for your country or region is not listed, contact your IBM reseller or IBM marketing representative. Response time may vary depending on the number and nature of the calls received.

<i>Support 24 hours a day, 7 days a week</i>	
Canada (Toronto only)	416-383-3344
Canada (all other)	1-800-565-3344
U.S.A. and Puerto Rico	1-800-772-2227
All other countries and regions	Go to http://www.ibm.com/pc/support/ , and click Support Phone List .

Appendix B. Product warranty and notices

This section contains product warranty and notices information.

Warranty Statement

This section contains the warranty period for your product and the IBM Statement of Limited Warranty.

Machine - IBM Data Migration Kit **Warranty period*** - One year

** Contact your place of purchase for warranty service information. Some IBM Machines are eligible for on-site warranty service depending on the country where service is performed.*

IBM Statement of Limited Warranty

Z125-4753-06 8/2000

Part 1 - General Terms

This Statement of Limited Warranty includes Part 1 - General Terms and Part 2 - Country-unique Terms. The terms of Part 2 replace or modify those of Part 1. The warranties provided by IBM in this Statement of Limited Warranty apply only to Machines you purchase for your use, and not for resale, from IBM or your reseller. The term "Machine" means an IBM machine, its features, conversions, upgrades, elements, or accessories, or any combination of them. The term "Machine" does not include any software programs, whether pre-loaded with the Machine, installed subsequently or otherwise. Unless IBM specifies otherwise, the following warranties apply only in the country where you acquire the Machine. Nothing in this Statement of Limited Warranty affects any statutory rights of consumers that cannot be waived or limited by contract. If you have any questions, contact IBM or your reseller.

The IBM Warranty for Machines

IBM warrants that each Machine 1) is free from defects in materials and workmanship and 2) conforms to IBM's Official Published Specifications ("Specifications"). The warranty period for a Machine is a specified, fixed period commencing on its Date of Installation. The date on your sales receipt is the Date of Installation unless IBM or your reseller informs you otherwise.

If a Machine does not function as warranted during the warranty period, and IBM or your reseller are unable to either 1) make it do so or 2) replace it with one that is at least functionally equivalent, you may return it to your place of purchase and your money will be refunded.

Extent of Warranty

The warranty does not cover the repair or exchange of a Machine resulting from misuse, accident, modification, unsuitable physical or operating environment, improper maintenance by you, or failure caused by a product for which IBM is not responsible. The warranty is voided by removal or alteration of Machine or parts identification labels.

THESE WARRANTIES ARE YOUR EXCLUSIVE WARRANTIES AND REPLACE ALL OTHER WARRANTIES OR CONDITIONS, EXPRESS OR IMPLIED, INCLUDING, BUT NOT LIMITED TO, THE IMPLIED WARRANTIES OR CONDITIONS OF MERCHANTABILITY AND FITNESS FOR A PARTICULAR PURPOSE. THESE WARRANTIES GIVE YOU SPECIFIC LEGAL RIGHTS AND YOU MAY ALSO HAVE OTHER RIGHTS WHICH VARY FROM JURISDICTION TO JURISDICTION. SOME JURISDICTIONS DO NOT ALLOW THE EXCLUSION OR LIMITATION OF EXPRESS OR IMPLIED WARRANTIES, SO THE ABOVE EXCLUSION OR LIMITATION MAY NOT APPLY TO YOU. IN THAT EVENT, SUCH WARRANTIES ARE LIMITED IN DURATION TO THE WARRANTY PERIOD. NO WARRANTIES APPLY AFTER THAT PERIOD.

Items Not Covered by Warranty

IBM does not warrant uninterrupted or error-free operation of a Machine.

Any technical or other support provided for a Machine under warranty, such as assistance via telephone with “how-to” questions and those regarding Machine set-up and installation, will be provided **WITHOUT WARRANTIES OF ANY KIND.**

Warranty Service

To obtain warranty service for a Machine, contact IBM or your reseller. If you do not register your Machine with IBM, you may be required to present proof of purchase.

During the warranty period, IBM or your reseller, if approved by IBM to provide warranty service, provides without charge certain types of repair and exchange service to keep Machines in, or restore them to, conformance with their Specifications. IBM or your reseller will inform you of the available types of service for a Machine based on its country of installation. At its discretion, IBM or your reseller will 1) either repair or exchange the failing Machine and 2) provide the service either at your location or a service center. IBM or your reseller will also manage and install selected engineering changes that apply to the Machine.

Some parts of IBM Machines are designated as Customer Replaceable Units (called "CRUs"), e.g., keyboards, memory, or hard disk drives. IBM ships CRUs to you for replacement by you. You must return all defective CRUs to IBM within 30 days of your receipt of the replacement CRU. You are responsible for downloading designated Machine Code and Licensed Internal Code updates from an IBM Internet Web site or from other electronic media, and following the instructions that IBM provides.

When warranty service involves the exchange of a Machine or part, the item IBM or your reseller replaces becomes its property and the replacement becomes yours. You represent that all removed items are genuine and unaltered. The replacement may not be new, but will be in good working order and at least functionally equivalent to the item replaced. The replacement assumes the warranty service status of the replaced item. Many features, conversions, or upgrades involve the removal of parts and their return to IBM. A part that replaces a removed part will assume the warranty service status of the removed part.

Before IBM or your reseller exchanges a Machine or part, you agree to remove all features, parts, options, alterations, and attachments not under warranty service.

You also agree to

1. ensure that the Machine is free of any legal obligations or restrictions that prevent its exchange;
2. obtain authorization from the owner to have IBM or your reseller service a Machine that you do not own; and
3. where applicable, before service is provided:
 - a. follow the problem determination, problem analysis, and service request procedures that IBM or your reseller provides;
 - b. secure all programs, data, and funds contained in a Machine;
 - c. provide IBM or your reseller with sufficient, free, and safe access to your facilities to permit them to fulfill their obligations; and
 - d. inform IBM or your reseller of changes in a Machine's location.

IBM is responsible for loss of, or damage to, your Machine while it is 1) in IBM's possession or 2) in transit in those cases where IBM is responsible for the transportation charges.

Neither IBM nor your reseller is responsible for any of your confidential, proprietary or personal information contained in a Machine which you return to IBM or your reseller for any reason. You should remove all such information from the Machine prior to its return.

Limitation of Liability

Circumstances may arise where, because of a default on IBM's part or other liability, you are entitled to recover damages from IBM. In each such instance, regardless of the basis on which you are entitled to claim damages from IBM (including fundamental breach, negligence, misrepresentation, or other contract or tort claim), except for any liability that cannot be waived or limited by applicable laws, IBM is liable for no more than

1. damages for bodily injury (including death) and damage to real property and tangible personal property; and
2. the amount of any other actual direct damages, up to the charges (if recurring, 12 months' charges apply) for the Machine that is subject of the claim. For purposes of this item, the term "Machine" includes Machine Code and Licensed Internal Code.

This limit also applies to IBM's suppliers and your reseller. It is the maximum for which IBM, its suppliers, and your reseller are collectively responsible.

UNDER NO CIRCUMSTANCES IS IBM LIABLE FOR ANY OF THE FOLLOWING: 1) THIRD-PARTY CLAIMS AGAINST YOU FOR DAMAGES (OTHER THAN THOSE UNDER THE FIRST ITEM LISTED ABOVE); 2) LOSS OF, OR DAMAGE TO, YOUR RECORDS OR DATA; OR 3) SPECIAL, INCIDENTAL, OR INDIRECT DAMAGES OR FOR ANY ECONOMIC CONSEQUENTIAL DAMAGES, LOST PROFITS OR LOST SAVINGS, EVEN IF IBM, ITS SUPPLIERS OR YOUR RESELLER IS INFORMED OF THEIR POSSIBILITY. SOME JURISDICTIONS DO NOT ALLOW THE EXCLUSION OR LIMITATION OF INCIDENTAL OR CONSEQUENTIAL DAMAGES, SO THE ABOVE LIMITATION OR EXCLUSION MAY NOT APPLY TO YOU.

Governing Law

Both you and IBM consent to the application of the laws of the country in which you acquired the Machine to govern, interpret, and enforce all of your and IBM's rights, duties, and obligations arising from, or relating in any manner to, the subject matter of this Agreement, without regard to conflict of law principles.

Part 2 - Country-unique Terms

AMERICAS

BRAZIL

Governing Law: *The following is added after the first sentence:* Any litigation arising from this Agreement will be settled exclusively by the court of Rio de Janeiro.

NORTH AMERICA

Warranty Service: *The following is added to this Section:* To obtain warranty service from IBM in Canada or the United States, call 1-800-IBM-SERV (426-7378).

CANADA

Governing Law: *The following replaces “laws of the country in which you acquired the Machine” in the first sentence:* laws in the Province of Ontario.

UNITED STATES

Governing Law: *The following replaces “laws of the country in which you acquired the Machine” in the first sentence:* laws of the State of New York.

ASIA PACIFIC

AUSTRALIA

The IBM Warranty for Machines: *The following paragraph is added to this Section:* The warranties specified in this Section are in addition to any rights you may have under the Trade Practices Act 1974 or other similar legislation and are only limited to the extent permitted by the applicable legislation.

Limitation of Liability: *The following is added to this Section:* Where IBM is in breach of a condition or warranty implied by the Trade Practices Act 1974 or other similar legislation, IBM’s liability is limited to the repair or replacement of the goods or the supply of equivalent goods. Where that condition or warranty relates to right to sell, quiet possession or clear title, or the goods are of a kind ordinarily acquired for personal, domestic or household use or consumption, then none of the limitations in this paragraph apply.

Governing Law: *The following replaces “laws of the country in which you acquired the Machine” in the first sentence:* laws of the State or Territory.

CAMBODIA, LAOS, AND VIETNAM

Governing Law: *The following replaces “laws of the country in which you acquired the Machine” in the first sentence:* laws of the State of New York.

The following is added to this Section: Disputes and differences arising out of or in connection with this Agreement shall be finally settled by arbitration which shall be held in Singapore in accordance with the rules of the International Chamber of Commerce (ICC). The arbitrator or arbitrators designated in conformity with those rules shall have the power to rule on their own

competence and on the validity of the Agreement to submit to arbitration. The arbitration award shall be final and binding for the parties without appeal and the arbitral award shall be in writing and set forth the findings of fact and the conclusions of law.

All proceedings shall be conducted, including all documents presented in such proceedings, in the English language. The number of arbitrators shall be three, with each side to the dispute being entitled to appoint one arbitrator.

The two arbitrators appointed by the parties shall appoint a third arbitrator before proceeding upon the reference. The third arbitrator shall act as chairman of the proceedings. Vacancies in the post of chairman shall be filled by the president of the ICC. Other vacancies shall be filled by the respective nominating party. Proceedings shall continue from the stage they were at when the vacancy occurred.

If one of the parties refuses or otherwise fails to appoint an arbitrator within 30 days of the date the other party appoints its, the first appointed arbitrator shall be the sole arbitrator, provided that the arbitrator was validly and properly appointed.

The English language version of this Agreement prevails over any other language version.

HONG KONG AND MACAU

Governing Law: *The following replaces “laws of the country in which you acquired the Machine” in the first sentence: laws of Hong Kong Special Administrative Region.*

INDIA

Limitation of Liability: *The following replaces items 1 and 2 of this Section:*

1. liability for bodily injury (including death) or damage to real property and tangible personal property will be limited to that caused by IBM’s negligence;
2. as to any other actual damage arising in any situation involving nonperformance by IBM pursuant to, or in any way related to the subject of this Statement of Limited Warranty, IBM’s liability will be limited to the charge paid by you for the individual Machine that is the subject of the claim.

JAPAN

Governing Law: *The following sentence is added to this Section:* Any doubts concerning this Agreement will be initially resolved between us in good faith and in accordance with the principle of mutual trust.

NEW ZEALAND

The IBM Warranty for Machines: *The following paragraph is added to this Section:* The warranties specified in this Section are in addition to any rights you may have under the Consumer Guarantees Act 1993 or other legislation which cannot be excluded or limited. The Consumer Guarantees Act 1993 will not apply in respect of any goods which IBM provides, if you require the goods for the purposes of a business as defined in that Act.

Limitation of Liability: *The following is added to this Section:* Where Machines are not acquired for the purposes of a business as defined in the Consumer Guarantees Act 1993, the limitations in this Section are subject to the limitations in that Act.

PEOPLE'S REPUBLIC OF CHINA (PRC)

Governing Law: *The following replaces this Section:* Both you and IBM consent to the application of the laws of the State of New York (except when local law requires otherwise) to govern, interpret, and enforce all your and IBM's rights, duties, and obligations arising from, or relating in any manner to, the subject matter of this Agreement, without regard to conflict of law principles.

Any disputes arising from or in connection with this Agreement will first be resolved by friendly negotiations, failing which either of us has the right to submit the dispute to the China International Economic and Trade Arbitration Commission in Beijing, the PRC, for arbitration in accordance with its arbitration rules in force at the time. The arbitration tribunal will consist of three arbitrators. The language to be used therein will be English and Chinese. An arbitral award will be final and binding on all the parties, and will be enforceable under the Convention on the Recognition and Enforcement of Foreign Arbitral Awards (1958).

The arbitration fee will be borne by the losing party unless otherwise determined by the arbitral award.

During the course of arbitration, this Agreement will continue to be performed except for the part which the parties are disputing and which is undergoing arbitration.

EUROPE, MIDDLE EAST, AFRICA (EMEA)

THE FOLLOWING TERMS APPLY TO ALL EMEA COUNTRIES: The terms of this Statement of Limited Warranty apply to Machines purchased from IBM or an IBM reseller.

Warranty Service:

If you purchase an IBM Machine in Austria, Belgium, Denmark, Estonia, Finland, France, Germany, Greece, Iceland, Ireland, Italy, Latvia, Lithuania, Luxembourg, Netherlands, Norway, Portugal, Spain, Sweden, Switzerland or United Kingdom, you may obtain warranty service for that Machine in any of those countries from either (1) an IBM reseller approved to perform warranty service or (2) from IBM. If you purchase an IBM Personal Computer Machine in Albania, Armenia, Belarus, Bosnia and Herzegovina, Bulgaria, Croatia, Czech Republic, Georgia, Hungary, Kazakhstan, Kirghizia, Federal Republic of Yugoslavia, Former Yugoslav Republic of Macedonia (FYROM), Moldova, Poland, Romania, Russia, Slovak Republic, Slovenia, or Ukraine, you may obtain warranty service for that Machine in any of those countries from either (1) an IBM reseller approved to perform warranty service or (2) from IBM.

If you purchase an IBM Machine in a Middle Eastern or African country, you may obtain warranty service for that Machine from the IBM entity within the country of purchase, if that IBM entity provides warranty service in that country, or from an IBM reseller, approved by IBM to perform warranty service on that Machine in that country. Warranty service in Africa is available within 50 kilometers of an IBM authorized service provider. You are responsible for transportation costs for Machines located outside 50 kilometers of an IBM authorized service provider.

Governing Law:

The applicable laws that govern, interpret and enforce rights, duties, and obligations of each of us arising from, or relating in any manner to, the subject matter of this Statement, without regard to conflict of laws principles, as well as Country-unique terms and competent court for this Statement are those of the country in which the warranty service is being provided, except that in 1) Albania, Bosnia-Herzegovina, Bulgaria, Croatia, Hungary, Former Yugoslav Republic of Macedonia, Romania, Slovakia, Slovenia, Armenia, Azerbaijan, Belarus, Georgia, Kazakhstan, Kyrgyzstan, Moldova, Russia, Tajikistan, Turkmenistan, Ukraine, and Uzbekistan, the laws of Austria apply; 2) Estonia, Latvia, and Lithuania, the laws of Finland apply; 3) Algeria, Benin, Burkina Faso, Cameroon, Cape Verde, Central African Republic, Chad, Congo, Djibouti, Democratic Republic of Congo, Equatorial Guinea, France, Gabon, Gambia, Guinea, Guinea-Bissau, Ivory Coast, Lebanon, Mali, Mauritania, Morocco, Niger, Senegal, Togo, and Tunisia, this Agreement will be construed and the legal relations between the parties will be determined in accordance with the French laws and all disputes arising out of this Agreement or related to its

violation or execution, including summary proceedings, will be settled exclusively by the Commercial Court of Paris; 4) Angola, Bahrain, Botswana, Burundi, Egypt, Eritrea, Ethiopia, Ghana, Jordan, Kenya, Kuwait, Liberia, Malawi, Malta, Mozambique, Nigeria, Oman, Pakistan, Qatar, Rwanda, Sao Tome, Saudi Arabia, Sierra Leone, Somalia, Tanzania, Uganda, United Arab Emirates, United Kingdom, West Bank/Gaza, Yemen, Zambia, and Zimbabwe, this Agreement will be governed by English Law and disputes relating to it will be submitted to the exclusive jurisdiction of the English courts; and 5) in Greece, Israel, Italy, Portugal, and Spain any legal claim arising out of this Statement will be brought before, and finally settled by, the competent court of Athens, Tel Aviv, Milan, Lisbon, and Madrid, respectively.

THE FOLLOWING TERMS APPLY TO THE COUNTRY SPECIFIED:

AUSTRIA AND GERMANY

The IBM Warranty for Machines: *The following replaces the first sentence of the first paragraph of this Section:* The warranty for an IBM Machine covers the functionality of the Machine for its normal use and the Machine's conformity to its Specifications.

The following paragraphs are added to this Section:

The minimum warranty period for Machines is six months. In case IBM or your reseller is unable to repair an IBM Machine, you can alternatively ask for a partial refund as far as justified by the reduced value of the unrepaired Machine or ask for a cancellation of the respective agreement for such Machine and get your money refunded.

Extent of Warranty: *The second paragraph does not apply.*

Warranty Service: *The following is added to this Section:* During the warranty period, transportation for delivery of the failing Machine to IBM will be at IBM's expense.

Limitation of Liability: *The following paragraph is added to this Section:* The limitations and exclusions specified in the Statement of Limited Warranty will not apply to damages caused by IBM with fraud or gross negligence and for express warranty.

The following sentence is added to the end of item 2: IBM's liability under this item is limited to the violation of essential contractual terms in cases of ordinary negligence.

EGYPT

Limitation of Liability: *The following replaces item 2 in this Section:* as to any other actual direct damages, IBM's liability will be limited to the total amount you paid for the Machine that is the subject of the claim. For purposes of this item, the term "Machine" includes Machine Code and Licensed Internal Code.

Applicability of suppliers and resellers (unchanged).

FRANCE

Limitation of Liability: *The following replaces the second sentence of the first paragraph of this Section:*In such instances, regardless of the basis on which you are entitled to claim damages from IBM, IBM is liable for no more than: (items 1 and 2 unchanged).

IRELAND

Extent of Warranty: *The following is added to this Section:* Except as expressly provided in these terms and conditions, all statutory conditions, including all warranties implied, but without prejudice to the generality of the foregoing all warranties implied by the Sale of Goods Act 1893 or the Sale of Goods and Supply of Services Act 1980 are hereby excluded.

Limitation of Liability: *The following replaces items one and two of the first paragraph of this Section:*1. death or personal injury or physical damage to your real property solely caused by IBM's negligence; and 2. the amount of any other actual direct damages, up to 125 percent of the charges (if recurring, the 12 months' charges apply) for the Machine that is the subject of the claim or which otherwise gives rise to the claim.

Applicability of suppliers and resellers (unchanged).

The following paragraph is added at the end of this Section: IBM's entire liability and your sole remedy, whether in contract or in tort, in respect of any default shall be limited to damages.

ITALY

Limitation of Liability: *The following replaces the second sentence in the first paragraph:*In each such instance unless otherwise provided by mandatory law, IBM is liable for no more than: 1. (unchanged) 2. as to any other actual damage arising in all situations involving nonperformance by IBM pursuant to, or in any way related to the subject matter of this Statement of Warranty, IBM's liability, will be limited to the total amount you paid for the Machine that is the subject of the claim. *Applicability of suppliers and resellers (unchanged).*

The following replaces the third paragraph of this Section: Unless otherwise provided by mandatory law, IBM and your reseller are not liable for any of the following: (items 1 and 2 unchanged) 3) indirect damages, even if IBM or your reseller is informed of their possibility.

SOUTH AFRICA, NAMIBIA, BOTSWANA, LESOTHO AND SWAZILAND

Limitation of Liability: *The following is added to this Section:* IBM's entire liability to you for actual damages arising in all situations involving nonperformance by IBM in respect of the subject matter of this Statement of Warranty will be limited to the charge paid by you for the individual Machine that is the subject of your claim from IBM.

UNITED KINGDOM

Limitation of Liability: *The following replaces items 1 and 2 of the first paragraph of this Section:*

1. death or personal injury or physical damage to your real property solely caused by IBM's negligence;
2. the amount of any other actual direct damages or loss, up to 125 percent of the charges (if recurring, the 12 months' charges apply) for the Machine that is the subject of the claim or which otherwise gives rise to the claim;

The following item is added to this paragraph: 3. breach of IBM's obligations implied by Section 12 of the Sale of Goods Act 1979 or Section 2 of the Supply of Goods and Services Act 1982.

Applicability of suppliers and resellers (unchanged).

The following is added to the end of this Section: IBM's entire liability and your sole remedy, whether in contract or in tort, in respect of any default shall be limited to damages. This publication was developed for products and services offered in the U.S.A.

IBM may not offer the products, services, or features discussed in this document in other countries. Consult your local IBM representative for information on the products and services currently available in your area. Any reference to an IBM product, program, or service is not intended to state or imply that only that IBM product, program, or service may be used. Any functionally equivalent product, program, or service that does not infringe any IBM intellectual property right may be used instead. However, it is the user's responsibility to evaluate and verify the operation of any non-IBM product, program, or service.

IBM may have patents or pending patent applications covering subject matter described in this document. The furnishing of this document does not give you any license to these patents. You can send license inquiries, in writing, to:

*IBM Director of Licensing
IBM Corporation
North Castle Drive
Armonk, NY 10504-1785
U.S.A.*

The following paragraph does not apply to the United Kingdom or any country where such provisions are inconsistent with local law:

INTERNATIONAL BUSINESS MACHINES CORPORATION PROVIDES THIS PUBLICATION "AS IS" WITHOUT WARRANTY OF ANY KIND, EITHER EXPRESS OR IMPLIED, INCLUDING, BUT NOT LIMITED TO, THE IMPLIED WARRANTIES OF NON-INFRINGEMENT, MERCHANTABILITY OR FITNESS FOR A PARTICULAR PURPOSE. Some states do not allow disclaimer of express or implied warranties in certain transactions, therefore, this statement may not apply to you.

This information could include technical inaccuracies or typographical errors. Changes are periodically made to the information herein; these changes will be incorporated in new editions of the publication. IBM may make improvements and/or changes in the product(s) and/or the program(s) described in this publication at any time without notice.

IBM may use or distribute any of the information you supply in any way it believes appropriate without incurring any obligation to you. Any references in this publication to non-IBM Web sites are provided for convenience only and do not in any manner serve as an endorsement of those Web sites. The materials at those Web sites are not part of the materials for this IBM product, and use of those Web sites is at your own risk. Any performance data contained herein was determined in a controlled environment. Therefore, the result obtained in other operating environments may vary significantly. Some measurements may have been made on development-level systems and there is no guarantee that these measurements will be the same on generally available systems. Furthermore, some measurements may have been estimated through extrapolation. Actual results may vary. Users of this document should verify the applicable data for their specific environment.

Processing date data

This IBM hardware product and IBM software products that might be packaged with it have been designed, when used in accordance with their associated documentation, to process date data correctly within and between the 20th and 21st centuries, provided all other products (for example, software, hardware, and firmware) used with these products properly exchange accurate date data with them.

IBM cannot take responsibility for the date data processing capabilities of non-IBM products, even if those products are preinstalled or otherwise distributed by IBM. You should contact the vendors responsible for those products directly to determine the capabilities of their products and update them if needed. This IBM hardware product cannot prevent errors that might occur if software, upgrades, or peripheral devices you use or exchange data with do not process date data correctly.

The foregoing is a Year 2000 Readiness Disclosure.

Trademarks

The following terms are trademarks of the IBM Corporation in the United States or other countries or both:

IBM

HelpCenter

Microsoft and Windows are trademarks of Microsoft Corporation in the United States, other countries, or both.

Intel is a trademark of the Intel Corporation in the United States, other countries or both.

Other company, product, and service names may be trademarks or service marks of others.

Electronic Emissions Notices

IBM Data Migration Kit

Federal Communications Commission (FCC) statement

Note: This equipment has been tested and found to comply with the limits for a Class B digital device, pursuant to Part 15 of the FCC Rules. These limits are designed to provide reasonable protection against harmful interference in a residential installation. This equipment generates, uses, and can radiate radio frequency energy and, if not installed and used in accordance with the instructions, may cause harmful interference to radio communications. However, there is no guarantee that interference will not occur in a particular installation. If this equipment does cause harmful interference to radio or television reception, which can be determined by turning the equipment off and on, the user is encouraged to try to correct the interference by one or more of the following measures:

- Reorient or relocate the receiving antenna.
- Increase the separation between the equipment and receiver.

- Connect the equipment into an outlet on a circuit different from that to which the receiver is connected.
- Consult an IBM authorized dealer or service representative for help.

Properly shielded and grounded cables and connectors must be used in order to meet FCC emission limits. Proper cables and connectors are available from IBM authorized dealers. IBM is not responsible for any radio or television interference caused by using other than recommended cables and connectors or by unauthorized changes or modifications to this equipment. Unauthorized changes or modifications could void the user's authority to operate the equipment.

This device complies with Part 15 of the FCC Rules. Operation is subject to the following two conditions: (1) this device may not cause harmful interference, and (2) this device must accept any interference received, including interference that may cause undesired operation.

Responsible party:

International Business Machines Corporation
New Orchard Road
Armonk, NY 10504
Telephone: 1-919-543-2193

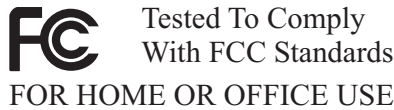

Industry Canada Class B emission compliance statement

This Class B digital apparatus complies with Canadian ICES-003.

Avis de conformité a la réglementation d'Industrie Canada

Cet appareil numérique de la classe B est conforme à la norme NMB-003 du Canada.

Deutsche EMV-Direktive (electromagnetische Verträglichkeit)

Zulassungsbcheinigung laut dem Deutschen Gesetz über die elektromagnetische Verträglichkeit von Geräten (EMVG) vom 30. August 1995 (bzw. der EMC EG Richtlinie 89/336):

Dieses Gerät ist berechtigt in Übereinstimmung mit dem Deutschen EMVG das EG-Konformitätszeichen - CE - zu führen. Verantwortlich für die Konformitätserklärung nach Paragraph 5 des EMVG ist die:

IBM Deutschland Informationssysteme GmbH, 70548 Stuttgart.

Informationen in Hinsicht EMVG Paragraph 3 Abs. (2) 2:

Das Gerät erfüllt die Schutzanforderungen nach EN 50082-1 und EN 55022 Klasse B.

EN 50082-1 Hinweis:

“Wird dieses Gerät in einer industriellen Umgebung betrieben (wie in EN 50082-2 festgelegt), dann kann es dabei eventuell gestört werden. In solch einem FA11 ist der Abstand bzw. die Abschirmung zu der industriellen Störquelle zu vergrößern.”

Anmerkung:

Um die Einhaltung des EMVG sicherzustellen sind die Geräte, wie in den IBM Handbüchern angegeben, zu installieren und zu betreiben.

European Union - emission directive

This product is in conformity with the protection requirements of EU Council Directive 89/366/ECC on the approximation of the laws of the Member States relating to electromagnetic compatibility.

IBM can not accept responsibility for any failure to satisfy the protection requirements resulting from a non-recommended modification of the product, including the fitting of non-IBM option cards.

This product has been tested and found to comply with the limits for Class B Information Technology Equipment according to European Standard EN 55022. The limits for Class B equipment were derived for typical residential environments to provide reasonable protection against interference with licensed communication devices.

Union Européenne - Directive Conformité électromagnétique

Ce produit est conforme aux exigences de protection de la Directive 89/336/EEC du Conseil de l'UE sur le rapprochement des lois des États membres en matière de compatibilité électromagnétique.

IBM ne peut accepter aucune responsabilité pour le manquement aux exigences de protection résultant d'une modification non recommandée du produit, y compris l'installation de cartes autres que les cartes IBM.

Ce produit a été testé et il satisfait les conditions de l'équipement informatique de Classe B en vertu de Standard européen EN 55022. Les conditions pour l'équipement de Classe B ont été définies en fonction d'un contexte résidentiel ordinaire afin de fournir une protection raisonnable contre l'interférence d'appareils de communication autorisés.

Unione Europea - Directiva EMC (Conformidad electromagnética)

Este producto satisface los requisitos de protección del Consejo de la UE, Directiva 89/336/CEE en lo que a la legislatura de los Estados Miembros sobre compatibilidad electromagnética se refiere.

IBM no puede aceptar responsabilidad alguna si este producto deja de satisfacer dichos requisitos de protección como resultado de una modificación no recomendada del producto, incluyendo el ajuste de tarjetas de opción que no sean IBM.

Este producto ha sido probado y satisface los límites para Equipos Informáticos Clase B de conformidad con el Estándar Europeo EN 55022. Los límites para los equipos de Clase B se han establecido para entornos residenciales típicos a fin de proporcionar una protección razonable contra las interferencias con dispositivos de comunicación licenciados.

Union Europea - Normativa EMC

Questo prodotto è conforme alle normative di protezione ai sensi della Direttiva del Consiglio dell'Unione Europea 89/336/CEE sull'armonizzazione legislativa degli stati membri in materia di compatibilità elettromagnetica.

IBM non accetta responsabilità alcuna per la mancata conformità alle normative di protezione dovuta a modifiche non consigliate al prodotto, compresa l'installazione di schede e componenti di marca diversa da IBM.

Le prove effettuate sul presente prodotto hanno accertato che esso rientra nei limiti stabiliti per le apparecchiature di informatica Classe B ai sensi della Norma Europea EN 55022. I limiti delle apparecchiature della Classe B sono stati stabiliti al fine di fornire ragionevole protezione da interferenze mediante dispositivi di comunicazione in concessione in ambienti residenziali tipici.

이 기기는 가정용으로 전자파 적합등록을 기기로서
주거지역에서는 물론 모든 지역에서 사용 할 수 있습니다.

この装置は、情報処理装置等電波障害自主規制協議会（VCCI）の基準に基づきクラスB情報技術装置です。この装置は、家庭環境で使用することを目的としていますが、この装置がラジオやテレビジョン受信機に近接して使用されると、受信障害を引き起こすことがあります。
取扱説明書に従って正しい取り扱いをして下さい。

Japanese statement of compliance for products less than or equal to 20 A per phase

高調波ガイドライン適合品

Appendix C. Troubleshooting, hints and tips

The following section describes troubleshooting assistance.

Troubleshooting

If you have problems performing the data migration, refer to the following troubleshooting instructions for assistance. If you receive an error message and have problems performing the data migration refer to the possible causes below:

1. Make sure you are logged on properly to both computers. Refer to this table for logon requirements:

New Computer Operating System	Previous Computer Operating System	Logon Requirements
Windows 2000	Windows 2000	You must logon to your new and previous computer with the same user name and password to perform the transfer process. That user name must be part of the Administrators group on both machines.
Windows 2000	Windows 95, 98 or Me	You must logon to your new and previous computer with the same user name and password to perform the transfer process. That user name must be part of the Administrators group on the new machine
Windows 95, 98 or Me	Windows 95, 98 or Me	You do not have to logon to Windows on either machine to perform the transfer process

For information on logging on to Windows, changing user passwords, and verifying whether a user name is part of the Administrators group, see "Hints and tips" on page C-2.

Note: Not all operating system combinations are supported. See the "Supported operating system combinations" section at the beginning of this manual to verify that your combination is supported

2. Check to make sure your new and previous computers don't have the same computer name. If they do, change the name of one of them. See "Hints and tips" for information on how to check and change a computer name in Windows.
3. Make sure you have enough free space on your previous computer. To transfer data successfully, your previous computer must have free space equal to the amount of data you are transferring at one time. Check the free space on your C drive to make sure you have enough. If not, you can perform the migration several times transferring smaller amounts of data each time

Hints and tips

Refer to the contents of this section for additional instructions related to performing the data migration.

Logging on to your Windows computer with a user name and password

To perform the data migration successfully, you must follow the log on instructions provided in "Performing the data migration" on page 1-19. If your new or previous computer is running Windows 2000 you must log on to that computer with a user name that is part of the Administrators group. If your new computer is running Windows 2000, you must log on to your new and previous computer with the same user name and password. See the instructions below for information on how to log on to Windows.

Windows 2000

You must log on to your Windows 2000 machine with a user name that is part of the Administrators group. If you know the user name and password of a user that is part of the administrator's group (this could be the built-in administrator account or an account you created as part of the Administrators group), follow the procedure under "Logging on to Windows 2000 with a user name that is part of the Administrators group". If you don't know the password of the administrator account and are unsure whether a user name is part of the Administrator's group, follow the procedure under "Checking whether a user name is part of the Administrators group in Windows 2000" on page C-3.

Logging on to Windows 2000 with a user name that is part of the Administrators group

1. If you are already logged on as a user that is not part of the Administrators group, close all programs, click Start and point to Shut Down.
2. In the Shut Down Windows window, choose Log Off User where User is the user name you are currently logged on as. Click **OK**.

3. The Log On Windows box will open requesting a user name and password. In the User name box enter a user name that is part of the Administrators group and the password of that user in the password box. Click **OK**.
4. Windows will log you on as that user name.

Checking whether a user name is part of the Administrators group in Windows 2000

1. Click **Start**, point to **Settings**, and then click **Control Panel**.
2. In the Control Panel, double-click **Users and Passwords**.
3. On the Users tab, under "Users for this computer", locate your user name that you know the password for. Check whether Administrators is listed under the Group section for that user name. If so, that user is part of the Administrators group. If you are not already logged on as that user, follow the instructions above under "Logging on to Windows 2000 with a user name that is part of the Administrators group" on page C-2. If there are no user names that you know the password for and that are part of the Administrators group, contact your administrator to either get the Administrator user name password or to have your user name added to the Administrators group.

Windows Me and Windows 98

1. Click **Start**, then Log Off user, where user is the user name you are currently logged in with (you may not be logged on as any user).
2. The Log Off Windows dialog box displays the message, Are you sure you want to log off? Click **Yes**.
3. If you will be logging on to Windows with an existing user name and password, enter them in the Enter Windows Password window. Click **OK** and you will be logged on.
4. If you will be creating a new user name, type the new user name into the User name: box and enter a password for that user name. Click **OK**.
5. The Set Windows Password window will open. In the Confirm new password: box, enter in the new password. Click **OK** and you will be logged on.

Windows 95

1. Click **Start**, then **Shut Down**.
2. On the Shut Down Windows window, choose **Close all programs and log on as a different user?**
3. If you will be logging on to Windows with an existing user name and password, enter them in the Enter Windows Password window. Click **OK** and you will be logged on.
4. If you will be creating a new user name, type the new user name into the User name: box and enter a password for that user name. Click **OK**.

5. The Set Windows Password window will open. In the Confirm new password: box, enter in the new password. Click **OK** and you will be logged on.

Changing a user name password on your Windows computer

To perform the data migration successfully, you must follow the log on instructions provided in "Performing the data migration" on page 1-19. If your new or previous computer is running Windows 2000 you must log on to that computer with a user name that is part of the Administrators group. If your new computer is running Windows 2000, you must log on to your new and previous computer with the same user name and password. Refer to the instructions below if you need information on changing a user name password in Windows.

Windows 2000

1. Log on to Windows 2000 with the user name you want to change to password for.
2. Press **Control+Alt+Delete** on the keyboard.
3. In the Windows Security window, click the **Change Password...** button.
4. In the Change Password window, enter the current password for that user in the Old Password box.
5. Enter the new password in the New password box and then enter the new password again into the Confirm New Password box. Click **OK**.
6. The Change Password window indicates that the password was changed. Click **OK**.
7. In the Windows Security window, click **Cancel**.
8. Log off of Windows 2000 and log back on using the new password. (For more information, see instructions under "Logging on to Windows 2000 with a user name that is part of the Administrators group" on page C-2)

Windows Me, Windows 98, Windows 95

1. Log on to Windows with the user name you want to change the password for.
2. Click **Start**, point to **Settings**, and then click **Control Panel**.
3. In the Control Panel, double-click **Passwords**.
4. In the Passwords Properties window, click the **Change Password** tab.
5. On the Change Passwords tab, click **Change Windows Password...**
6. If the Change Windows Password window is displayed with the message You may also change other passwords at the same time as your Windows password, click **OK**.
7. In the Change Windows Password window, enter in the old password and the new password and confirm the new password. Click **OK**.

8. A window will open indicating the password was successfully changed. Click **OK**.
9. Click **Close** on the Password Properties window.

Changing the name of a Windows computer

To perform the data migration successfully, your new and previous computers cannot have the same computer name. To change the name of a computer, see the following instructions.

Windows 2000

1. Click **Start**, point to **Settings**, and then click **Control Panel**.
2. On the Control Panel window, double-click on the **System** icon.
3. In the System Properties window, click on the **Network Identification** tab.
4. On the Network Identification tab, click the **Properties** button.
5. In Computer Name box type a new name for the computer. Click **OK**.
6. The Network Identification window opens and indicates the computer must be restarted. Click **OK** and the computer will restart.

Windows Me, Windows 98, and Windows 95

1. Click **Start**, point to **Settings**, and then click **Control Panel**.
2. On the Control Panel window, double-click on the **Network** icon.
3. In the Network window, click the **Identification** tab.
4. In the Computer name box on the Identification tab, type in a new name for the computer. Click **OK**.
5. The System Settings Change window opens and prompts you to restart your computer. Click **Yes** and the computer will restart.

Disabling file and print sharing

The File and Printer Sharing for Microsoft Networks component allows other computers on a network to access resources on your computer by using a Microsoft network. When you complete the data migration process, it is a good idea to disable file and print sharing on both computers. To do this, follow the procedures below.

Windows 2000

1. Click **Start**, point to **Settings**, and then click **Network and Dial-up Connections**. The Network and Dial-up Connections window will open.
2. Right-click the connection for the Local Area Connection for the ethernet adapter you are using and then click **Properties**.

3. In the box underneath "Components checked are used by this connection" on the connection properties window, uncheck **File and Printer Sharing for Microsoft Networks** if not already unchecked.
4. Click **OK** and the connection properties window will close.

Windows Me, Windows 98, and Windows 95

1. Click **Start**, point to **Settings**, and then click **Control Panel**.
2. Double-click **Network**.
3. On the Configuration tab, click **File and Print Sharing**.
4. In the File and Print Sharing window uncheck **I want to be able to give others access to my files** and **I want to be able to allow others to print to my printer(s)** if they are not already unchecked.



Part Number: 22P7603



Printed in the United States of America
on recycled paper containing 10%
recovered post-consumer fiber.

(1P) P/N: 22P7603

