

48X/32X/48X Max CD-RW Drive



User's Guide

48X/32X/48X Max CD-RW Drive



User's Guide

Note: Before using this information and the product it supports, read the information under the appendixes.

First Edition (September 2003)

© Copyright International Business Machines Corporation 2003. All rights reserved.

US Government Users Restricted Rights – Use, duplication or disclosure restricted by GSA ADP Schedule Contract with IBM Corp.

Safety: Read first

Before installing this product, read the Safety Information.

مج، يجب قراءة دات السلامة

Antes de instalar este produto, leia as Informações de Segurança.

Prije instalacije ovog produkta obavezno pročitajte Sigurnosne Upute.

Před instalací tohoto produktu si přečtěte příručku bezpečnostních instrukcí.

Læs sikkerhedsforskrifterne, før du installerer dette produkt.

Ennen kuin asennat tämän tuotteen, lue turvaohjeet kohdasta Safety Information.

Avant d'installer ce produit, lisez les consignes de sécurité.

Vor der Installation dieses Produkts die Sicherheitshinweise lesen.

Πριν εγκαταστήσετε το προϊόν αυτό, διαβάστε τις πληροφορίες ασφάλειας (safety information).

לפני שתתקינו מוצר זה, קראו את הוראות הבטיחות.

A termék telepítése előtt olvassa el a Biztonsági előírásokat!

Prima di installare questo prodotto, leggere le Informazioni sulla Sicurezza.

製品の設置の前に、安全情報をお読みください。

본 제품을 설치하기 전에 안전 정보를 읽으십시오.

Пред да се инсталира овој продукт, прочитајте информацијата за безбедност.

Lees voordat u dit product installeert eerst de veiligheidsvoorschriften.

Les sikkerhetsinformasjonen (Safety Information) før du installerer dette produktet.

Przed zainstalowaniem tego produktu, należy zapoznać się z książką "Informacje dotyczące bezpieczeństwa" (Safety Information).

Antes de instalar este produto, leia as Informações sobre Segurança.

Перед установкой продукта прочтите инструкции по технике безопасности.

Pred inštaláciou tohto zariadenia si pečítajte Bezpečnostné predpisy.

Pred namestitvijo tega proizvoda preberite Varnostne informacije.

Antes de instalar este producto lea la información de seguridad.

Läs säkerhetsinformationen innan du installerar den här produkten.

安裝本產品之前，請先閱讀「安全資訊」。

Contents

Safety: Read first	iii
-------------------------------------	------------

About this book	vii
Registering your option	vii

Installation and user's guide 1

Introduction	1
Product description	1
Software description	2
Before you begin	2
System requirements	2
Handling Instructions	2
Product views	3
Front view of the drive	3
Back view of the drive	3
Installing the Drive	4
Step 1. Opening the computer	4
Step 2. Unpacking the drive	4
Step 3. Selecting an IDE port	4
Step 4. Setting the configuration jumper	4
Step 5. Mounting the drive in the bay	5
Step 6. Attaching the cables to the drive	6
Step 7. Completing the hardware installation	6
Step 8. Updating your computer configuration	6
Step 9. Installing the CD-RW drive software	7
Using CD-R and CD-RW discs	7
Handling and caring for a CD	8
Using the drive	9
Caring for the CD-RW drive	9
Loading a CD	9
Ejecting a CD manually	10
Using the software	10

Appendix A. Product specifications . . . 13

Appendix B. Problem solving 17

Troubleshooting	17
Your computer or CD-RW drive does not operate correctly or the busy indicator light does not come on.	17

You cannot format a CD-RW disc	17
You cannot create a multi-session disc.	18
You cannot successfully write to a CD-R or CD-RW disc.	18
You cannot eject a CD..	18
You cannot read from the CD after successfully writing to it.	18
You cannot access the CD-RW drive, or the drive icon does not display (Windows XP)	19
The CD cannot be read.	19
There is no sound from the CD.	20
The connectors on the audio cables provided do not fit the connector on your audio adapter.	20
You receive "buffer underrun" error messages when copying CDs or making data CDs.	20
Your computer will not shut down or stand by	20
Your computer hangs at boot-up	20

Appendix C. Customizing the device-driver configuration settings . . 21

Changing the Auto Insert Notify and DMA parameters for Windows Me.	21
Changing the DMA parameter setting for Windows XP	21
Enabling DMA for Windows 2000 Professional	22

Appendix D. Service and Support . . . 23

Online technical support	23
Telephone technical support	23

Appendix E. IBM Statement of Limited Warranty - Z125-4753-07 - 11/2002 . . . 25

<u>Part 2 - Country-unique Terms</u>	28
<u>Part 3 - Warranty Information</u>	39

Appendix F. Notices 43

Federal Communications Commission (FCC) statement	44
Trademarks	47

About this book

This manual contains instructions for installing, configuring, and troubleshooting the IBM® 48X/32X/48X Max CD-RW Drive. The manual is divided into the following sections:

Installation and user's guide

This guide contains the product description and installation instructions in the following languages:

- Brazilian Portuguese
- Czechoslovakian
- English
- French
- German
- Italian
- Japanese
- Simplified Chinese
- Slovak
- Spanish
- Traditional Chinese
- Turkish

Appendixes

The appendixes contain device-driver special configuration settings and help and service information. They also contain the product warranties and notices.

Note: The illustrations in this manual might be slightly different from your hardware.

Registering your option

Thank you for purchasing this IBM product. Please take a few moments to register your product and provide us with information that will help IBM to better serve you in the future. Your feedback is valuable to us in developing products and services that are important to you, as well as in developing better ways to communicate with you. Register your option on the IBM Web site at

<http://www.ibm.com/pc/register>

IBM will send you information and updates on your registered product unless you indicate on the Web site questionnaire that you do not want to receive further information.

Installation and user's guide

This section provides the product description, installation instructions, and instructions for using and maintaining the IBM 48X/32X/48X Max CD-ReWritable (CD-RW) Drive.

Introduction

This section describes this option and the software that comes with it. This section also contains some information you will need before you install the option.

Product description

The IBM 48X/32X/48X Max CD-RW Drive can write and read CD-RW and CD-Recordable (CD-R) discs, and can read mass-produced stamped CDs. CDs created with this drive are compatible with Multi-Read CD-ROM and DVD-ROM drives that can read CD-RW discs and other media, and with older non-Multi-Read CD-ROM drives that can read only CD-R and CD-ROM discs.

The drive can write to a CD-R disc at up to 48 times the standard CD-ROM speed, recording data at up to 7200 KB¹ per second. At this rate, the drive can record an 80-minute CD-R disc in a little more than three minutes. The drive writes to CD-RW and CD-R discs at different speeds. The drive can write to an ultra-speed CD-RW disc at up to 32 times the standard CD-ROM speed, recording data at up to 4800 KB per second. At this rate, the drive can record an 80-minute CD-RW disc in less than four minutes. The drive can also read data at up to 48 times the standard CD-ROM speed.

This drive incorporates EasyWrite technology. EasyWrite is an open industry standard created to make CD-RW easier to use. Benefits include background formatting and physical defect management by the drive. For more information, go to www.mt-rainier.org.

The CD-RW drive can be installed only in a computer that uses the integrated drive electronics (IDE) or the enhanced IDE (EIDE) architecture.

In addition to this manual, provided on the *User's Guide and Software CD*, the option kit includes:

- 48X/32X/48X Max CD-RW drive
- One audio cable
- Four mounting screws
- One IDE cable
- *Laser Safety Guide*

Contact your place of purchase if an item is missing or damaged. Be sure to retain your proof of purchase. It might be required to receive warranty service. See Appendix E, "IBM Statement of Limited Warranty - Z125-4753-07 - 11/2002", on page 25 for warranty information.

1. KB equals approximately 1024 bytes when referring to data transfer speeds.

Software description

The *User's Guide and Software* CD contains the following software:

- IBM RecordNow: With RecordNow, you can record your own CDs in a variety of ways. You can use the CD copier function to make backup copies of your CDs, or you can make data CDs from files on your hard disk drive. You can create audio CDs from MP3 files or from other audio CDs. RecordNow can also create disk images on your hard drive and record previously created disc images to CD.
- IBM Drive Letter Access (DLA): You can use DLA to access your CD-RW drive using a drive letter. You can copy files to recordable media using the windows command line or by using the drag-and-drop method.
- UDF Reader: You can use the UDF Reader to read CDs you wrote with DLA in other PCs.

Before you begin

Read the following information before you start your installation. You must complete the following steps to install the drive:

1. Determine which IDE port to use and the corresponding configuration setting.
2. Place or change the configuration jumper on the drive (you might need to make changes to the configuration jumpers of other devices).
3. Install the drive in a drive bay.
4. Configure the system.
5. Install software.

If you do not understand these procedures or are unsure about your ability to perform all the procedures described, contact a qualified computer technician to install the CD-RW drive for you.

System requirements

Before you begin installing the drive, be sure your computer meets the following system requirements.

- Minimum microprocessor: Intel® Pentium® processor (or the equivalent)
- Minimum RAM: 32 MB
- Available IDE connection
- Available internal power connection
- Available 5.25-in. drive bay
- One of the following operating systems:
 - Microsoft® Windows® Millennium Edition (Me)
 - Microsoft Windows 2000 Professional
 - Microsoft Windows XP

You might need a flathead or Phillips screwdriver to complete the installation. You might also need to refer to the documentation that comes with your computer. Be sure to have this documentation available.

Handling Instructions

To protect your CD-RW drive during installation, observe the following precautions:

- Handle the drive with care. Dropping or jarring the drive can damage the components inside the drive housing.

- Keep the CD-RW drive in its antistatic bag until you are ready to install the drive in your computer. Limit your movement. Movement can cause static electricity buildup.
- Do not force insertion of the power cable. Doing so might damage the connector or the drive.

Product views

The following sections illustrate the front and back views of the CD-RW drive.

Front view of the drive

Refer to the following illustration to identify parts that might be referred to in the installation instructions.

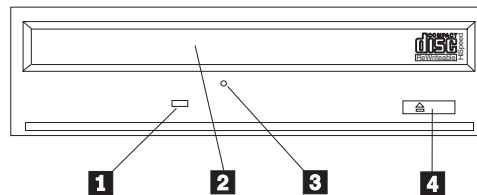

Note: Front bezel design might be different (varies by supplier).

1 Busy indicator: This light comes on when the drive reads from, writes to, or plays a CD.

2 CD tray: Use this tray to load and unload a CD.

3 Manual-eject hole: This hole provides access to the eject mechanism to remove a CD from the drive when normal ejection procedures do not work.

4 Eject/Load button: When pushed, this button opens or closes the CD tray.

Back view of the drive

Refer to the following illustration to identify parts that might be referred to in the installation instructions.

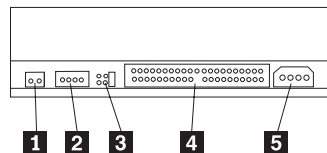

1 Reserved

2 Audio-out connector: Use this connector to attach the CD-RW drive to a sound adapter.

3 Configuration pins: These pins are used to set the drive configuration.

4 IDE connector: Use this connector to attach the CD-RW drive to the IDE cable.

5 DC-power connector: Use this connector to attach the CD-RW drive to the computer power supply cable.

Installing the Drive

To install the drive into your computer, do the following:

Step 1. Opening the computer

To open your computer, do the following:

1. Turn off the computer and all attached devices.
2. Unplug the power cords for the computer and all attached devices.
3. Remove the cover from the computer. See the documentation for your computer for instructions on removing the cover.

Step 2. Unpacking the drive

To unpack the drive, do the following:

1. In order to discharge any accumulated static electricity, touch an unpainted metal surface for at least two seconds. Take the bag that the drive is packed in and touch the bag to an unpainted metal surface for at least two seconds.
2. Remove the drive from the bag.

If you must put the drive down, place the antistatic bag on a flat padded surface, and place the drive on the bag with the component side facing up.

Step 3. Selecting an IDE port

Newer computers typically have two IDE ports. If your computer has two IDE ports, use the secondary IDE port to connect the CD-RW drive. Typically the secondary IDE port is adjacent to the primary IDE port that connects to your hard disk drive. The IDE port you select and the cable position you select determine which configuration jumper setting you use for the drive. See “Step 4. Setting the configuration jumper” for instructions on setting the configuration jumper.

- If you have two IDE ports, connect the CD-RW drive to the secondary IDE port with the IDE cable that comes with your drive. If the CD-RW drive is the only device on the secondary IDE port, you will use the master configuration setting. If there is another device on the secondary port in addition to the CD-RW drive, you will use the slave configuration setting.
- If you must attach the CD-RW drive to the same IDE port as a faster device, such as a hard disk drive, use the slave setting for the CD-RW drive and the master setting for the faster device. In some instances, the hard disk drive might require a master-with-slave-present setting when another device on the same cable is configured as a slave. For further information on setting configuration jumpers on other devices, see the documentation that came with your computer or with the device in question.
- Some non-IBM computers support the cable-select setting, where the position of the device on the cable determines whether a device is master or slave. See the documentation that comes with your computer to determine if your computer supports this setting.

Step 4. Setting the configuration jumper

The following illustration shows the master **1** setting, the slave **2** setting, and the cable-select **3** setting. Configure the CD-RW drive by placing a jumper over

one pair of pins corresponding to the setting you chose in Step 3.

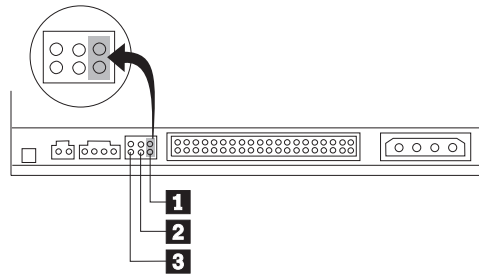

- If you are configuring the drive as master, set the jumper to the master **1** device setting. (This is how the drive is set when it is shipped.) If there is a second device on the IDE port, check that the device is configured as slave.
- If you are configuring the drive as slave, set the jumper to the slave **2** device setting. Check that the other device on the IDE port is configured as master (or master-with-slave-present).
- If you are configuring the drive as cable-select, set the jumper to the cable-select **3** device setting. If there is another device on the IDE port, check that the device is also configured for cable-select.

Step 5. Mounting the drive in the bay

Attention: Be sure to use the mounting screws in the option package when you are driving screws directly into the drive. Using screws that are too long might damage the drive.

You can mount the CD-RW drive in the computer either horizontally or vertically. If you mount the drive vertically, you must secure any CDs you place into the drive before you close the drive tray, or the CD-RW drive will not be able to read the CD properly. For further instructions on securing your CDs in a vertically mounted drive, see “Loading a CD” on page 9.

1. Slide the drive into the bay. Your computer might have specific required procedures for installing storage devices. Refer to the documentation that came with your computer for further instructions.
2. Align the drive-bay screw holes with the threaded holes in the drive housing or mounting bracket. Be sure to use the mounting screws provided with this drive. Using the wrong size screws might damage the drive. Thread the screws in loosely to check their position. Usually two screws are used on each side.
3. Check to ensure that the alignment is correct, and then tighten the screws to secure the drive. Do not overtighten.

Step 6. Attaching the cables to the drive

Connect the cables to the CD-RW drive as follows:

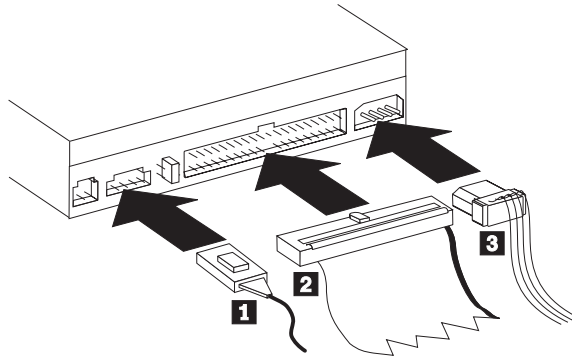

1. If you want to connect the CD-RW drive to your sound adapter or to the sound function on your system board, locate the included audio cables and determine which cable best fits the CD audio-in port on your sound adapter. Connect one end of the selected audio cable to the CD-RW drive audio-out connector **1**, and the other end of the cable to your sound adapter CD audio-in port. Save the other cable in case you use a different sound adapter in the future.

Note: Some computers have a smaller connector that is incompatible with the included audio cable. If your computer has this kind of connector, you must purchase a new audio cable.

2. Attach a 40-pin IDE-cable connector **2** to the IDE connector on the drive. Align the cable so that the color-coded edge is closest to the power cable connector **3**. Use the IDE cable provided with this option if there is no cable attached to the IDE port or if there is only one device connector on the IDE cable. If you use the included IDE cable, attach one end of the cable to your system board IDE port or to your IDE adapter, and the other end of the IDE cable to the CD-RW drive.
3. Locate one of the available power cables attached to your computer power source. Attach the four-pin power cable **3** to the CD-RW drive DC power connector.

Step 7. Completing the hardware installation

To complete the hardware installation, do the following:

1. Be sure that the drive is securely mounted and the connectors are firmly attached.
2. Be sure the cables do not interfere with the computer cover and do not block any fan blade or air-flow paths.
3. Reinstall the computer cover.
4. Reconnect all devices and check any devices that might have become disconnected, such as the keyboard, mouse, and monitor.
5. Connect all power cords to electrical outlets.

Step 8. Updating your computer configuration

After you have completed the hardware installation, restart your computer. Usually, the configuration-setup information screen is displayed when you turn on your computer. If you do not see this screen, check your computer documentation for information about accessing the configuration or setup utility program.

To see the configuration information for most IBM computers, press F1 during startup when the IBM graphic displays in the upper right corner of the screen. When you have finished reviewing the information, save the changes and exit.

Step 9. Installing the CD-RW drive software

The *User's Guide and Software* CD contains two software applications for use with the CD writing functions of your CD-RW drive:

- IBM RecordNow
- IBM Drive Letter Access (DLA)

There is another application that will be useful in some circumstances.

- UDF Reader

For more information on these applications, see "Software description" on page 2.

To install these applications, do the following:

1. Insert the *User's Guide and Software* CD into your CD-RW drive.
2. If the CD starts automatically, follow the on-screen instructions. If it does not start automatically, do the following:
 - a. Click **Start->Run** and type `e:\engage.bat` where *e* is the letter of your CD-ROM drive.
 - b. Click **OK**.
3. Select your language.
4. Select the application you want to install.
5. Follow the on-screen instructions.

Using CD-R and CD-RW discs

The CD-RW drive can write to both CD-R and CD-RW discs. CD-RW discs can be erased and reused many times, while CD-R discs can be written to only once.





Carefully handle and clean discs, especially writable media types such as CD-R and CD-RW discs, so that they remain readable. You can prolong the life of your discs by using the following precautions:

- Always store CD-ROMs in their original packaging
- Always store CD-ROMs out of direct sunlight
- Always store CD-ROMs away from direct heat sources
- Remove CD-ROMs from the computer when not in use
- Check CD-ROM for cracks BEFORE each use
- DO NOT force CD-ROMs into the computer/packaging
- DO NOT bend or flex CD-ROMs

Notes:

1. CD-R discs are playable on most audio CD players. CD-RW discs are playable only on some audio CD players.
2. Some consumer audio players will only play discs recorded on media labelled specifically for audio.
3. CD-R media is rated by write-speed. For 48x write mode, 48x media is required. For best results, limit write-speed to the media speed rating. The Record Now Software included in the option kit will allow you to limit the maximum recording speed.

4. CD-RW media is also rated by write-speed. The IBM 48X/32X/48X Max CD-RW drive supports writing only CD-RW discs rated at 4x or higher. The maximum write speed will be printed on the media packaging or the disc itself.
5. The following table shows the compatibility matrix for ultra, high, and low-speed CD-RW media:

Media Rating	Write
No rating, 2x 	Not supported
Multispeed, 1x2x4x, 4x, 1x-4x 	Yes
High Speed, 4x-10x, 4x-12x, 8-10x 	Yes
Ultra Speed, 16x-24x, 32x 	Yes

Handling and caring for a CD

CDs are high-density media that must be handled with care and kept clean to ensure that they remain readable. These precautions will help to prolong the life of your CDs.

Attention: Wiping a CD using a circular motion might cause loss of data.

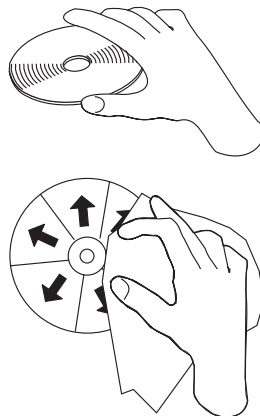

Attention: Do not use CDs that have cracks.

- Handle the CD by the edges or by the center hole. Do not touch the surface of the CD.
- To remove dust or fingerprints, wipe the CD from the center to the edge with a soft, lint-free cloth.
- Do not write on the surface.

- Do not place the CD in direct sunlight.
- Do not use commercial cleaners to clean the CD.
- Do not bend the CD.

Using the drive

This section provides information on how to handle your CD-RW drive, and how to load CDs into your CD-RW drive.

Caring for the CD-RW drive

To protect your CD-RW drive during operation, observe the following precautions:

- Remove any CD in the drive before moving the drive.
- Do not insert foreign objects into the drive.
- Do not remove the drive cover or attempt to service the drive.
- Do not operate the drive under any of the following conditions:
 - High temperature, high humidity, or direct sunlight
 - Excessive vibration, sudden shock, or inclined surface
 - Excessive dust

Loading a CD

To load a CD into a horizontally mounted CD-RW drive, do the following:

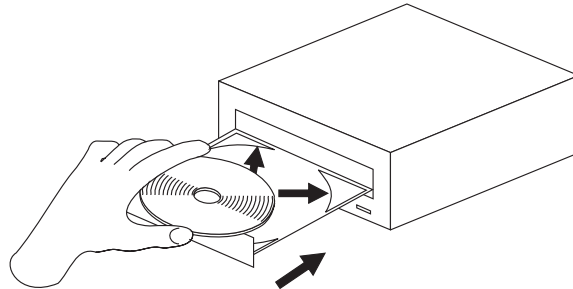

1. Press the **Eject/Load** button. The tray slides out of the drive.
2. Insert the CD into the loading tray.
3. Close the loading tray by pressing the **Eject/Load** button, or by gently pushing the tray in.

Attention: Do not force the tray to open; do not insert objects into the CD tray. If your tray does not open when you press the **Eject/Load** button, see “Ejecting a CD manually” on page 10.

To load a CD into a vertically mounted CD-RW drive, do the following:.

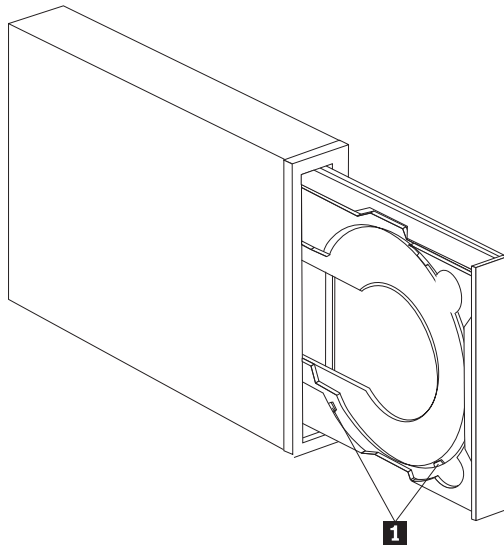

Note: Drive CD tray design might be different than shown (varies by supplier).

1. Press the **Eject/Load** button .
2. Insert the CD into the tray, make sure the disc is placed securely behind the vertical mounting tabs **1** .
3. Close the loading tray by pressing the **Eject/Load** button, or by gently pushing the tray in.

Ejecting a CD manually

If you press the **Eject/Load** button and the tray does not slide out, turn off the computer. Straighten a large paper clip to form a tool, as shown in the illustration. The straightened end must extend at least 45 mm (1.8 in.). Insert the extended end into the manual-eject hole on the front of the drive (see “Front view of the drive” on page 3). Push the paper clip into the hole until the tray opens. Gently pull out the tray until you can remove the CD.

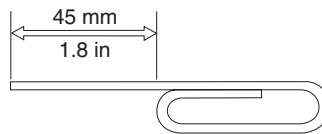

Using the software

This section explains the software associated with the CD-RW drive.

Using Windows XP native recording with your CD-RW drive

Your CD-RW drive is fully compatible with the recording functions built into Windows XP. You can record data CDs without adding any additional software if you are running Windows XP. If you install the DLA software that comes with your CD-RW drive, Windows Native recording will be disabled and DLA will perform the formatting and writing functions. The CDs that you create with Windows native recording can be used in most versions of Windows without any special readers.

To copy files to your CD using Windows XP native recording, drag the files to the drive letter using Explorer. Windows will stage the files in a temporary location. When you are ready to write the files to your CD, open the drive letter and click **Write these files to CD**.

Note: Trying to eject the disc will prompt you to record the files.

Using IBM Drive Letter Access (DLA)

IBM Drive Letter Access (DLA) is included on the *User's Guide and Software* CD so you can write data to CD-RW and CD-R media.

CD-RW discs can be formatted two ways. The first way is normal UDF, and the second way is UDF with EasyWrite extensions. EasyWrite extensions allow the disc to be formatted in the background while data is being written to it. While this is more convenient, EasyWrite written discs cannot be read in other computers without the UDF reader.

To format a blank CD-R or CD-RW, do the following:

1. Insert a blank disc into your CD-RW drive.
2. Open **My Computer**.
3. Right-Click on the Drive icon and select **Format**.
4. Check the EasyWrite box to background format the disc or leave it unchecked to do a normal format.

To write to formatted media, do the following:

1. Insert a previously formatted disc into your CD-RW drive. The disc will be mounted for write access.
2. Drag and drop files to the CD-RW/CD-R drive letter icon, or use move the files through Windows Explorer.

To make CD-R media compatible in other computers, do the following:

1. Right-click on the drive letter in **My Computer**.
2. Click **Make Compatible**.

Note: After making compatible and appending 9 times, a CD-R disk will become read-only.

Note: CD-RW media can be written many times; CD-R media can only be written to once.

Note: On EasyWrite discs, it will take 20 to 60 seconds to suspend or shut down your PC. Interrupting this process will cause data loss.

Note: The drive light is not active during EasyWrite background formatting.

Using the UDF Reader

The UDF Reader software is provided to read DLA-written discs on PCs that do not have DLA installed. When you install DLA into your system, a copy of the UDF Reader installer is copied to your system as well. You can install the UDF Reader on other PCs to read your own UDF created discs.

Note: The UDF Reader is not required on any computer that has DLA installed. It is only used on computers that share media with computers that write with DLA.

Note: EasyWrite-formatted media cannot be read in any computer without an EasyWrite UDF reader installed.

Note: To read CD-R discs formatted with DLA in computers without CD-RW drives, use the **Make Compatible** function listed in the drive properties menu.

Using the RecordNow software

RecordNow allows you to record Audio CDs, Data CDs, and copy existing CDs. Detailed information about using RecordNow is included in the RecordNow help. You can access RecordNow help by pressing F1 inside the RecordNow menu.

To start RecordNow in Windows Me, or Windows 2000, select **Start->Programs->IBM RecordNow**.

To start RecordNow in Windows XP, select **Start->All Programs->RecordNow**.

Once RecordNow is started, select one of the following three processes:

- **Make an exact copy:** Select this to back up your own CDs, or make copies of CDs you have previously created. After you select this option, RecordNow will prompt you to insert your disc to be copied, and then will prompt you when to insert a blank disc.
- **Make a music disc:** Select this option to create an audio CD. The second screen will ask if you want to make an audio CD from MP3 and Wave files on your hard disk, or from other audio CDs. There is also a selection to make a disc for an MP3 player, which is a specially formatted data disc that can be played in stand-alone MP3 players.
- **Make a data disc:** Select this option to create a disc containing data files from your hard disk. RecordNow will ask whether you want to format the disc for DLA or make a data disc for sharing with others. RecordNow will prompt you to insert a blank disc. Then a screen will appear that will enable you to drag-and-drop files, or browse to find files on your hard disk.
- Once RecordNow is started, you can also perform two special operations:
 - Clicking on the **Favorites** button will allow you to load a previously saved audio, data, MP3, or CD image to burn a new copy.
 - Dropping an ISO or GI CD image into the files box for a data CD will record the image file directly onto the CD.
 - To make an ISO image of a CD with RecordNow, select **Copy a CD** and set the destination recorder to **record file to hard disk**.

Note: To limit the recording speed in RecordNow select Options, and in the Advanced tab window pick the speed of your choice from the drop down box entitled, *Limit the Maximum recorder speed*.

Appendix A. Product specifications

This appendix includes the following information:

- Physical specifications
- Power requirements
- Environmental requirements
- Drive write/read speeds
- Drive performance
- Format capabilities

Physical specifications

The physical specifications² of the 48X/32X/48X Max CD-RW drive are listed in the following table.

<i>Physical specifications:</i>	
Height	42 mm (1.7 in.)
Width	149 mm (5.9 in.)
Length	185 mm (7.7 in.)
Weight	1.0 kg (2.2 lb.)

Power requirements

The following table lists the power specifications by voltage level for the 48X/32X/48X Max CD-RW drive. The power specifications are measured at the drive power connector and are nominal values.

<i>Power specifications:</i>		
At Voltage	+12 V dc	+5 V dc
Operational current rating is	1.5 A	1.0 A

2. Product-description data represents IBM's design objectives and is provided for comparative purposes; actual results might vary, based on a variety of factors. This product data does not constitute a warranty. Data is subject to change without notice.

The following table lists the environmental specifications for the CD-RW drive. You can mount the drive vertically or horizontally.

Environmental requirements

<i>Environmental Requirements:</i>		
Specification	Operational	Nonoperational
Temperature (noncondensing)	+5° C to +45° C (+41° F to +113° F)	-40° C to +60° C (-40° F to + 140° F)
Relative humidity (noncondensing)	8% to 80%	5% to 90%

Write/Read speeds

The following table lists the write/read speeds for the CD-RW drive.

<i>Drive Write/Read Speeds:</i>	
Function	Supported Speed
Read (CD-ROM/CD-R)	20-48x (CAV)
Read (CD-RW/Audio)	17-40x (CAV)
Write (CD-R disc)	20-48x (CAV)
Write (CD-RW disc)	16-32x (Z-CAV) or 20-32x (P-CAV)

Media Speed Compatibility

The following table lists the media speed compatibility for the CD-RW drive.

Function	CD-R Media Compatibility	CD-RW Media Compatibility
Reads	ALL	ALL
Writes	4x, 8x, 12x, 16x, 24x, 32x, 40x, 48x	Multispeed (1x2x4x, 4x, 1x-4x) High Speed (4x-10x, 8x-10x, 10x, 12x) Ultra Speed (24x, 32x)
Note: Media or drive speed must support the listed write speed of the media.		

Drive-performance specifications

The following table lists the performance specifications of the CD-RW drive.

<i>Drive performance:</i>	
Feature	Specification
Burst data transfer rate	16.7 MB (1 MB is approximately 1 000 000 bytes of data) per second (ATA PIO Mode 4) 16.7 MB per second (ATA multi-word DMA Mode 2), 33.3 MB per second (Ultra DMA Mode 2)

Average access time (including latency)	100 ms (20-48x, CAV)
Cache memory (Read/Write)	2 MB
Disc diameter	12 cm (4.7 in.) (8cm [3 in.])
Rotational speed (CD-ROM/CD-R)	9600 rpm
Mean time between failures (MTBF)	125 000 POH (duty 10%)
Buffer underrun protection	SuperLink [®] or SmartBURN [®]

The following table summarizes the CD format capabilities of the RecordNow program. Refer to the Sonic software online user's guide for the most recent information on CD format capabilities.

Format	Copy capability	Create capability
CD-DA (Red Book)	Yes	Yes
CD+G	Yes	No
CD TEXT	Yes	Yes
CD-ROM (Yellow Book)	Yes	Yes
CD-ROM XA (Mode 2)	Yes	No
CD-I (Green Book)	Yes	No
CD-I Bridge	No	No
Video CD (White Book)	Yes	No
CD-R (Orange Book P II)	Yes	Yes
CD-RW (Orange Book P III)	Yes	Yes
Multisession CD	Yes	Yes
CD Extra (Blue Book)	Yes	No
Photo CD	Yes	No
Mixed-Mode CD	Yes	No
Bootable CD	Yes	No
Disc at Once	Yes	No
Track at Once	Yes	Yes
Session at Once	Yes	No

The CD-RW drive uses the following methods to write files to CDs:

- **Disc at Once:** The drive writes to the entire disc in a single pass; data cannot be added at a later time.
- **Track at Once:** The drive copies one track at a time to the disc.
- **Multisession:** The drive writes several sessions to a disc; each session has at least one track.

Listed below are descriptions of different CD formats that appear in the table.

CD-Digital Audio: This format records audio CDs that can be played on audio CD players.

CD Extra: This format records audio and data in a multisession format.

CD TEXT: This format records audio CDs with the album names and song titles encoded.

CD-ROM (Mode 1): This format is used for most CD-ROM applications.

CD-ROM XA (Mode 2 Form 1 and Mode 2 Form 2) or CD-ROM Extended Architecture: This standard was created for playback of multimedia content.

CD-I (Mode 2 Form 1 and Mode 2 Form 2) and CD-I Ready³: This format is used for home entertainment systems.

CD-I Bridge: This format records a combination of Kodak Photo CDs and Video CDs that can be played on TV set-top players and personal computers.

Photo CD (single and multisession): This format records CDs that are playable on TV set-top video CD players and most DVD systems.

3. The CD-RW drive does not have the necessary audio circuitry and decoding functions for CD-I playback, but it can be read from and write to CDs in this format.

Appendix B. Problem solving

Computer problems can be caused by hardware, software, or user error. You might be able to use the information in this section to solve problems yourself, or gather helpful information you can pass on to a service technician.

Review the following list for any problem descriptions that might fit your situation.

Troubleshooting

Your computer or CD-RW drive does not operate correctly or the busy indicator light does not come on.

Take the following actions:

1. Check that the CD is loaded with the label side up.
2. Check that all devices are correctly connected to the computer and the electrical outlet. If all devices are correctly connected and you are still experiencing problems, go to step 3.
3. Turn off the computer, unplug the cables from the electrical outlets for your computer and all attached devices, and remove the computer cover.
4. Check that all power and IDE cables are securely attached. Disconnect the IDE cable and check for bent or misaligned pins. If you do not find any problems, reconnect the IDE cable. Reattach all cables and power cords and replace the computer cover. Turn on the computer, restart the system, and then attempt to open the CD tray by pressing the **Eject/Load** button. If the tray fails to open and the busy indicator light does not come on, turn off the computer and try using another 4-pin dc power cable.
5. Check that the color-coded edge on the IDE cable aligns with pin 1 on the IDE port and is closest to the power cable on the 48X/32X/48X Max CD-ReWritable drive See "Step 3. Selecting an IDE port" on page 4.
6. Check that the IDE cable is connected to the proper IDE port connection. See "Step 3. Selecting an IDE port" on page 4 for more information.
7. Check the CD-RW drive and any other device on the IDE cable for the proper master/slave jumper settings. See "Step 4. Setting the configuration jumper" on page 4 for more information.
8. If the middle connector on the IDE cable is attached to the IDE port on the system board, remove the connector and reattach the cable. If there is only one device on the IDE port, attach the connector at one end of the cable to the IDE port and the connector at the other end to the device, leaving the middle connector (if there is one) open. If there are two devices on the IDE port, attach the connector at one end of the cable to the IDE port. If there is a hard disk drive, attach it to the connector at the other end of the cable and attach the CD-RW drive to the middle connector.

You cannot format a CD-RW disc

Take the following actions:

1. Check your media. This CD-RW drive cannot format 1X or 2X speed media.
2. Erase the CD-RW with the following procedure, then try formatting again.

- Remove all discs from drives.
 - Start RecordNow.
 - Select **Erase**.
 - Select **For use with record now**.
 - Insert your media when prompted.
 - At the prompt "The disc you have inserted is not blank, would you like to erase it now?", select **Yes**.
 - After the media erase completes, Select the **Cancel** button in RecordNow
 - Exit RecordNow.
 - Eject the media.
3. If you are using a third party bus-master driver, check with the driver manufacturer to ensure it supports CD-RW drives.

You cannot create a multi-session disc.

Be sure that there is enough space left on the media for another session. Writing a session requires about 15 MB in addition to the data that is recorded.

You cannot successfully write to a CD-R or CD-RW disc.

Take the following action:

1. Verify that the process is not being interrupted by a screen saver, an antivirus program, an Internet or e-mail program, or other software. Disable the functions that might interrupt the write operation.
2. Verify that your computer has the minimum processor listed in the system requirements for this option. See "System requirements" on page 2 for more information.
3. Verify that the hard disk drive has been defragmented.
4. Replace the disc if it is damaged or scratched.
5. Verify that the write-speed is correct for this disc.

You cannot eject a CD.

Take the following actions after ensuring that the drive is not in the process of writing:

1. Close all applications.
2. Eject the CD with the software application. Double-click **My Computer**. Click the **CDR/RW** icon. Click **Eject**.
3. Use the **Eject/Load** button.
4. Turn off the computer. Wait 45 seconds; then turn on the computer and try using the **Eject/Load** button again.
5. If other methods do not work, use the manual-eject hole, using instructions given in "Ejecting a CD manually" on page 10.

You cannot read from the CD after successfully writing to it.

Take the following actions:

1. If you can read the CD in another CD player or you can see previous sessions, the directory information might be damaged on the volume, making it unreadable. Check the Sonic software online user's guide for more troubleshooting ideas.
2. You might have a damaged CD-R or CD-RW disc. Try a new CD-R disc or CD-RW disc, or another brand of disc.

3. If you can read from a CD-RW disc in the CD-RW drive, but not in another optical drive, be sure that a UDF Reader program is installed on the computer that contains the other optical drive. For more information on the UDF Reader program, see "Using the UDF Reader" on page 11.
4. Verify that you are not attempting to write the disc under extreme environmental conditions such as the following:
 - low temperature: 5° C (41° F) or below
 - high temperature: 45° C (113 °F) or above
 - excessive shock: >0.5 G
 - excessive vibration: >0.1 G
5. Make sure the CD-R session is closed. See "Using the RecordNow software" on page 12 for help. A non-closed audio disc cannot be played in your car or home CD player.

You cannot access the CD-RW drive, or the drive icon does not display (Windows XP)

If the CD-RW drive has been properly installed, there will be an icon for the drive in the My Computer window. If you double-click the **My Computer** icon and there is no drive icon present in the displayed window, check to see that the drive has been properly installed, and that the configuration jumper has been correctly set. For more information, see "Step 4. Setting the configuration jumper" on page 4. Next, restart your computer. If a drive icon is still not found, continue with the following steps.

1. Click **Start** → **Settings** → **Control Panel**.
2. Click **System**.
3. Click the **Device Manager** tab.
4. Double-click **View Devices by Type**.
 - a. Click **Hard Disk Controllers** on the Device Manager list. Ensure that there are no conflicts with the controller. Ensure that the device status indicates that the controller is working properly.
 - b. Select **CD-RW** from the **Device Manager** list. Verify that there is a CD-RW device and that no conflicts exist. The device status will indicate that the device is working properly.
5. Click **OK**.
6. Restart the computer.

If the device icon is still not present, check cable connections, device jumper settings, and resolve any existing conflicts.

If you have installed Microsoft Media Player 9.x and this problem occurs, follow this procedure:

1. Insert the CD-RW User's Guide and Software CD.
2. Open **My Computer** and **Explore the CD-RW Drive**.
3. Double-click on **cdrtlfx.exe**
4. Reboot your computer.

The CD cannot be read.

Take the following actions:

1. The CD might be dirty; clean it as described in "Handling and caring for a CD" on page 8.

2. The CD might be defective; try another CD.
3. The CD is not ISO-9660 or High Sierra Group-compatible. Check with your place of purchase.

There is no sound from the CD.

Take the following actions:

1. Check that you are using an audio CD and not a data CD.
2. Adjust the sound-adapter volume control. See the documentation that comes with your sound adapter and audio-CD player program.
3. Turn off the computer, unplug the cables from the electrical outlets for your computer and all attached devices, and remove the computer cover. Check that the audio-signal cable connects the 48X/32X/48X Max CD-RW Drive to the sound adapter.

The connectors on the audio cables provided do not fit the connector on your audio adapter.

Some audio adapters might require a special cable. See the documentation that comes with your sound adapter.

You might have to purchase a separate audio cable for the 48X/32X/48X Max CD-RW Drive. The audio-out connector on the 48X/32X/48X Max CD-RW Drive requires a MPC-2 compliant Molex 70553 or equivalent connector. (To locate the drive audio connector, see "Back view of the drive" on page 3.) If you are using an IBM computer or IBM sound adapter, see Appendix E, "IBM Statement of Limited Warranty - Z125-4753-07 - 11/2002", on page 25 for assistance.

You receive "buffer underrun" error messages when copying CDs or making data CDs.

Take the following actions:

- If the file source is a network or removable device, copy the files to the local hard disk first.
- If using CD copier, select **Advanced** and check the **Copy to Hard Disk** option.
- If using RecordNow, select **Options->Advanced**, and make sure that **Burn-Proof** is checked.
- Try reducing the write speed.
- Make sure the source and target drives are being operated in DMA mode. See Appendix C, "Customizing the device-driver configuration settings", on page 21 for more information.

Your computer will not shut down or stand by

- If you are using an EasyWrite disc, eject it from **My Computer**.
- If you have Record Now open, close it.

Your computer hangs at boot-up

- Remove media from the drive and restart.
- Check with your computer manufacturer for updated BIOS that properly recognize EasyWrite discs.

Appendix C. Customizing the device-driver configuration settings

Windows XP and Windows Me have two device-driver configuration parameters: Auto Insert Notify and DMA.

The Auto Insert Notify parameter enables the computer to start audio CD software as soon as a CD is inserted into the CD-RW drive.

The DMA parameter improves computer performance by having the computer DMA controller handle data transfers from the CD to memory, freeing the computer microprocessor to perform more important tasks. For example, activating DMA might make movies and games run more smoothly because the microprocessor is allocating more processing time to video.

Changing the Auto Insert Notify and DMA parameters for Windows Me

To change the Auto Insert Notify and DMA parameter settings in Windows Me do the following:

1. Click **Start** → **Settings** → **Control Panel**.
2. Click on **view all control panel options**.
3. Double-click **System**.
4. Click the **Device Manager** tab.
5. Double-click **CD-ROM**.
6. Click on the drive that you want to modify.
7. Click the **Settings** tab.
8. Click to select or to clear the **Auto Insert Notification** check box and the **DMA** check box, depending on which parameters you want to enable or disable.
9. Click **OK**.

Changing the DMA parameter setting for Windows XP

To change the DMA parameter setting from the Windows XP desktop do the following:

1. Click **Start** → **Control Panel**.
2. Click **Switch to classic view**.
3. Double-click **System**.
4. Click the **Hardware** tab.
5. Click **Device Manager** button.
6. Click on the **IDE ATA/ATAPI controllers** to expand the tree.
7. Double-click on the controller that corresponds to where your CD-RW is located (**Primary IDE** or **Secondary IDE**).
8. Click the **Advanced Settings** tab.
9. Select the appropriate **Transfer Mode** pull-down that corresponds to the CD-RW location (**Device 0** for Master, **Device 1** for Slave).
10. Select **DMA if Available**.
11. Click **OK**.

Enabling DMA for Windows 2000 Professional

To change the parameter setting for Windows 2000, do the following:

1. Click **Start** → **Settings** → **Control Panel**.
2. Double-click **System**.
3. Click the **Hardware** tab.
4. Click **Device Manager**.
5. Click the **IDE ATA/ATAPI** controller to expand the tree.
6. Click the device that corresponds to the controller where your CD-RW Drive is located (**Primary IDE** or **Secondary IDE**).
7. Click the **Advanced Settings** tab.
8. Click **Transfer Mode**, and select **DMA** if it is available.
9. Click **OK**.
10. Click **Close** to close the System Properties window. A message is displayed informing you that the system settings have changed.
11. Click **OK** to restart your computer.

Appendix D. Service and Support

The following information describes the technical support that is available for your product, during the warranty period or throughout the life of the product. Refer to your IBM Statement of Limited Warranty for a full explanation of IBM warranty terms.

Online technical support

Online technical support is available during the life of your product through the Personal Computing Support Web site at www-3.ibm.com/pc/support/site.wss/.

During the warranty period, assistance for replacement or exchange of defective components is available. In addition, if your IBM option is installed in an IBM computer, you might be entitled to service at your location. Your technical support representative can help you determine the best alternative.

Telephone technical support

Installation and configuration support through the IBM HelpCenter[®] will be withdrawn or made available for a fee, at IBM's discretion, 90 days after the option has been withdrawn from marketing. Additional support offerings, including step-by-step installation assistance, are available for a nominal fee.

To assist the technical support representative, have available as much of the following information as possible:

- Option name
- Option number
- Proof of purchase
- Computer manufacturer, model, serial number (if IBM), and manual
- Exact wording of the error message (if any)
- Description of the problem
- Hardware and software configuration information for your system

If possible, be at your computer. Your technical support representative might want to walk you through the problem during the call.

For the support telephone number and support hours by country, refer to the following table. If the number for your country or region is not listed, contact your IBM reseller or IBM marketing representative. Response time may vary depending on the number and nature of the calls received.

Phone numbers are subject to change without notice. For the latest phone number list, go to www-3.ibm.com/pc/support/site.wss/ and click **Support Phone List**.

Country or Region	Telephone Number	Country or Region	Telephone Number
Argentina	0800-666-0011	Malaysia	03-7727-7800
Australia	1300-130-426	Mexico	001-866-434-2080
Austria	01-24592-5901	Netherlands	020-514-5770

Country or Region	Telephone Number	Country or Region	Telephone Number
Belgium	Dutch 02-210-9820 French 02-210-9800	New Zealand	0800-446-149
Bolivia	0800-0189	Norway	66 81 11 00
Brazil	55-11-3889-8986	Peru	0-800-50-866
Canada	1-800-565-3344 Toronto 416-383-3344	Philippines	632-995-2225
Chile	800-224-488	Portugal	21-791 51 47
China (PRC)	800-810-1818	Russia	095-940-2000
China (Hong Kong S.A.R.)	852-2825-7799	Singapore	1800-840-9911
Columbia	980-912-3021	Spain	91-662 49 16
Denmark	45 20 82 00	Sweden	08-477 4420
Ecuador	1-800-426911 (option #4)	Switzerland	058-333-09-00
Finland	09-459 69 60	Taiwan	886-2-2725-9799
France	02 38 55 74 50	Thailand	66-2-273-4000
Germany	07032-1549 201	Turkey	00-800-446-32-041
Indonesia	021-523-8535	United Kingdom	0-1475-555 055
Ireland	01-815-9202	United States	1-800-426-7378
Italy	02-7031-6101	Uruguay	000-411-005-6649
Japan	Consumer customers 0120-887-870 Business customers 0120-887-874	Venezuela	0-800-100-2011
Luxembourg	298-977 5063	Vietnam	848-8295-160

Appendix E. IBM Statement of Limited Warranty - Z125-4753-07 - 11/2002

Part 1 - General Terms

This Statement of Limited Warranty includes Part 1 - General Terms, Part 2 - Country-unique Terms, and Part 3 - Warranty Information. The terms of Part 2 replace or modify those of Part 1. The warranties provided by IBM in this Statement of Limited Warranty apply only to Machines you purchase for your use, and not for resale. The term "Machine" means an IBM machine, its features, conversions, upgrades, elements, or accessories, or any combination of them. The term "Machine" does not include any software programs, whether pre-loaded with the Machine, installed subsequently or otherwise. Nothing in this Statement of Limited Warranty affects any statutory rights of consumers that cannot be waived or limited by contract.

What this Warranty Covers

IBM warrants that each Machine 1) is free from defects in materials and workmanship and 2) conforms to IBM's Official Published Specifications ("Specifications") which are available on request. The warranty period for the Machine starts on the original Date of Installation and is specified in Part 3 - Warranty Information. The date on your invoice or sales receipt is the Date of Installation unless IBM or your reseller informs you otherwise. Many features, conversions, or upgrades involve the removal of parts and their return to IBM. A part that replaces a removed part will assume the warranty service status of the removed part. Unless IBM specifies otherwise, these warranties apply only in the country or region in which you purchased the Machine.

THESE WARRANTIES ARE YOUR EXCLUSIVE WARRANTIES AND REPLACE ALL OTHER WARRANTIES OR CONDITIONS, EXPRESS OR IMPLIED, INCLUDING, BUT NOT LIMITED TO, THE IMPLIED WARRANTIES OR CONDITIONS OF MERCHANTABILITY AND FITNESS FOR A PARTICULAR PURPOSE. SOME STATES OR JURISDICTIONS DO NOT ALLOW THE EXCLUSION OF EXPRESS OR IMPLIED WARRANTIES, SO THE ABOVE EXCLUSION MAY NOT APPLY TO YOU. IN THAT EVENT, SUCH WARRANTIES ARE LIMITED IN DURATION TO THE WARRANTY PERIOD. NO WARRANTIES APPLY AFTER THAT PERIOD. SOME STATES OR JURISDICTIONS DO NOT ALLOW LIMITATIONS ON HOW LONG AN IMPLIED WARRANTY LASTS, SO THE ABOVE LIMITATION MAY NOT APPLY TO YOU.

What this Warranty Does not Cover

This warranty does not cover the following:

- any software programs, whether pre-loaded or shipped with the Machine, or installed subsequently;
- failure resulting from misuse (including but not limited to use of any Machine capacity or capability, other than that authorized by IBM in writing), accident, modification, unsuitable physical or operating environment, or improper maintenance by you;
- failure caused by a product for which IBM is not responsible; and

- any non-IBM products, including those that IBM may procure and provide with or integrate into an IBM Machine at your request.

The warranty is voided by removal or alteration of identification labels on the Machine or its parts.

IBM does not warrant uninterrupted or error-free operation of a Machine.

Any technical or other support provided for a Machine under warranty, such as assistance via telephone with "how-to" questions and those regarding Machine set-up and installation, is provided **WITHOUT WARRANTIES OF ANY KIND**.

How to Obtain Warranty Service

If the Machine does not function as warranted during the warranty period, contact IBM or your reseller to obtain warranty service. If you do not register the Machine with IBM, you may be required to present proof of purchase as evidence of your entitlement to warranty service.

What IBM Will Do to Correct Problems

When you call for service, you must follow the problem determination and resolution procedures that IBM specifies. A technician will attempt to make an initial diagnosis of your problem and help you resolve it over the telephone.

The type of warranty service applicable to your Machine is specified in Part 3 - Warranty Information.

You are responsible for downloading and installing designated Machine Code (microcode, basic input/output system code (called "BIOS"), utility programs, device drivers, and diagnostics delivered with an IBM Machine) and other software updates from an IBM Internet Web site or from other electronic media, and following the instructions that IBM provides.

If your problem can be resolved with a Customer Replaceable Unit ("CRU") (e.g., keyboard, mouse, speaker, memory, hard disk drive and other easily replaceable parts), IBM will ship these parts to you for replacement by you.

If the Machine does not function as warranted during the warranty period and your problem cannot be resolved over the telephone, through your application of Machine Code or software updates, or with a CRU, IBM or your reseller, if approved by IBM to provide warranty service, will either, at its discretion, 1) repair it to make it function as warranted, or 2) replace it with one that is at least functionally equivalent. If IBM is unable to do either, you may return the Machine to your place of purchase and your money will be refunded.

IBM or your reseller will also manage and install selected engineering changes that apply to the Machine.

Exchange of a Machine or Part

When the warranty service involves the exchange of a Machine or part, the item IBM or your reseller replaces becomes its property and the replacement becomes yours. You represent that all removed items are genuine and unaltered. The replacement may not be new, but will be in good working order and at least

functionally equivalent to the item replaced. The replacement assumes the warranty service status of the replaced item.

Your Additional Responsibilities

Before IBM or your reseller exchanges a Machine or part, you agree to remove all features, parts, options, alterations, and attachments not under warranty service.

You also agree to:

1. ensure that the Machine is free of any legal obligations or restrictions that prevent its exchange;
2. obtain authorization from the owner to have IBM or your reseller service a Machine that you do not own; and
3. where applicable, before service is provided:
 - a. follow the service request procedures that IBM or your reseller provides;
 - b. backup or secure all programs, data, and funds contained in the Machine;
 - c. IBM or your reseller with sufficient, free, and safe access to your facilities to permit IBM to fulfill its obligations; and
 - d. inform IBM or your reseller of changes in the Machine's location.
4. (a) ensure all information about identified or identifiable individuals (Personal Data) is deleted from the Machine (to the extent technically possible), (b) allow IBM, your reseller or an IBM supplier to process on your behalf any remaining Personal Data as IBM or your reseller considers necessary to fulfill its obligations under this Statement of Limited Warranty (which may include shipping the Machine for such processing to other IBM service locations around the world), and (c) ensure that such processing complies with any laws applicable to such Personal Data.

Limitation of Liability

IBM is responsible for loss of, or damage to, your Machine only while it is 1) in IBM's possession or 2) in transit in those cases where IBM is responsible for the transportation charges.

Neither IBM nor your reseller are responsible for any of your confidential, proprietary or personal information contained in a Machine which you return to IBM for any reason. You should remove all such information from the Machine prior to its return.

Circumstances may arise where, because of a default on IBM's part or other liability, you are entitled to recover damages from IBM. In each such instance, regardless of the basis on which you are entitled to claim damages from IBM (including fundamental breach, negligence, misrepresentation, or other contract or tort claim), except for any liability that cannot be waived or limited by applicable laws, IBM is liable for no more than

1. damages for bodily injury (including death) and damage to real property and tangible personal property; and
2. the amount of any other actual direct damages, up to the charges (if recurring, 12 months' charges apply) for the Machine that is subject of the claim. For purposes of this item, the term "Machine" includes Machine Code and Licensed Internal Code ("LIC").

This limit also applies to IBM's suppliers and your reseller. It is the maximum for which IBM, its suppliers, and your reseller are collectively responsible.

UNDER NO CIRCUMSTANCES IS IBM, ITS SUPPLIERS OR RESELLERS LIABLE FOR ANY OF THE FOLLOWING EVEN IF INFORMED OF THEIR POSSIBILITY: 1) THIRD PARTY CLAIMS AGAINST YOU FOR DAMAGES (OTHER THAN THOSE UNDER THE FIRST ITEM LISTED ABOVE); 2) LOSS OF, OR DAMAGE TO, DATA; 3) SPECIAL, INCIDENTAL, OR INDIRECT DAMAGES OR FOR ANY ECONOMIC CONSEQUENTIAL DAMAGES; OR 4) LOST PROFITS, BUSINESS REVENUE, GOODWILL OR ANTICIPATED SAVINGS. SOME STATES OR JURISDICTIONS DO NOT ALLOW THE EXCLUSION OR LIMITATION OF INCIDENTAL OR CONSEQUENTIAL DAMAGES, SO THE ABOVE LIMITATION OR EXCLUSION MAY NOT APPLY TO YOU. SOME STATES OR JURISDICTIONS DO NOT ALLOW LIMITATIONS ON HOW LONG AN IMPLIED WARRANTY LASTS, SO THE ABOVE LIMITATION MAY NOT APPLY TO YOU.

Governing Law

Both you and IBM consent to the application of the laws of the country in which you acquired the Machine to govern, interpret, and enforce all of your and IBM's rights, duties, and obligations arising from, or relating in any manner to, the subject matter of this Statement of Limited Warranty, without regard to conflict of law principles.

THESE WARRANTIES GIVE YOU SPECIFIC LEGAL RIGHTS AND YOU MAY ALSO HAVE OTHER RIGHTS WHICH VARY FROM STATE TO STATE OR JURISDICTION TO JURISDICTION.

Jurisdiction

All of our rights, duties, and obligations are subject to the courts of the country in which you acquired the Machine.

Part 2 - Country-unique Terms

AMERICAS

ARGENTINA

Governing Law: *The following is added after the first sentence:*

Any litigation arising from this Statement of Limited Warranty will be settled exclusively by the Ordinary Commercial Court of the city of Buenos Aires.

BRAZIL

Governing Law: *The following is added after the first sentence:*

Any litigation arising from this Statement of Limited Warranty will be settled exclusively by the court of Rio de Janeiro, RJ.

Peru

Limitation of Liability: *The following is added at the end of this section:*

In accordance with Article 1328 of the Peruvian Civil Code the limitations and exclusions specified in this section will not apply to damages caused by IBM's willful misconduct ("dolo") or gross negligence ("culpa inexcusable").

NORTH AMERICA

How to Obtain Warranty Service: *The following is added to this Section:*
To obtain warranty service from IBM in Canada or the United States, call 1-800-IBM-SERV (426-7378).

CANADA

Limitation of Liability: *The following replaces item 1 of this section:*

1. damages for bodily injury (including death) or physical harm to real property and tangible personal property caused by IBM's negligence; and

Governing Law: *The following replaces "laws of the country in which you acquired the Machine" in the first sentence:*
laws in the Province of Ontario.

UNITED STATES

Governing Law: *The following replaces "laws of the country in which you acquired the Machine" in the first sentence:*
laws of the State of New York.

ASIA PACIFIC

AUSTRALIA

What this Warranty Covers: *The following paragraph is added to this Section:*
The warranties specified in this Section are in addition to any rights you may have under the Trade Practices Act 1974 or other similar legislation and are only limited to the extent permitted by the applicable legislation.

Limitation of Liability: *The following is added to this Section:*
Where IBM is in breach of a condition or warranty implied by the Trade Practices Act 1974 or other similar legislation, IBM's liability is limited to the repair or replacement of the goods or the supply of equivalent goods. Where that condition or warranty relates to right to sell, quiet possession or clear title, or the goods are of a kind ordinarily acquired for personal, domestic or household use or consumption, then none of the limitations in this paragraph apply.

Governing Law: *The following replaces "laws of the country in which you acquired the Machine" in the first sentence:*
laws of the State or Territory.

CAMBODIA, LAOS, AND VIETNAM

Governing Law: *The following replaces "laws of the country in which you acquired the Machine" in the first sentence:*
laws of the State of New York, United States of America.

CAMBODIA, INDONESIA, LAOS, AND VIETNAM

Arbitration: The following is added under this heading:

Disputes arising out of or in connection with this Statement of Limited Warranty shall be finally settled by arbitration which shall be held in Singapore in accordance with the Arbitration Rules of Singapore International Arbitration Center ("SIAC Rules") then in effect. The arbitration award shall be final and binding for the parties without appeal and shall be in writing and set forth the findings of fact and the conclusions of law.

The number of arbitrators shall be three, with each side to the dispute being entitled to appoint one arbitrator. The two arbitrators appointed by the parties shall appoint a third arbitrator who shall act as chairman of the proceedings. Vacancies in the post of chairman shall be filled by the president of the SIAC. Other vacancies shall be filled by the respective nominating party. Proceedings shall continue from the stage they were at when the vacancy occurred.

If one of the parties refuses or otherwise fails to appoint an arbitrator within 30 days of the date the other party appoints its, the first appointed arbitrator shall be the sole arbitrator, provided that the arbitrator was validly and properly appointed.

All proceedings shall be conducted, including all documents presented in such proceedings, in the English language. The English language version of this Statement of Limited Warranty prevails over any other language version.

HONG KONG S.A.R. OF CHINA AND MACAU S.A.R. OF CHINA

Governing Law: *The following replaces "laws of the country in which you acquired the Machine" in the first sentence:*

laws of Hong Kong Special Administrative Region of China.

INDIA

Limitation of Liability: *The following replaces items 1 and 2 of this Section:*

1. liability for bodily injury (including death) or damage to real property and tangible personal property will be limited to that caused by IBM's negligence; and
2. as to any other actual damage arising in any situation involving nonperformance by IBM pursuant to, or in any way related to the subject of this Statement of Limited Warranty, , the charge paid by you for the individual Machine that is the subject of the claim. For purposes of this item, the term "Machine" includes Machine Code and Licensed Internal Code ("LIC").

Arbitration: *The following is added under this heading :*

Disputes arising out of or in connection with this Statement of Limited Warranty shall be finally settled by arbitration which shall be held in Bangalore, India in accordance with the laws of India then in effect. The arbitration award shall be final and binding for the parties without appeal and shall be in writing and set forth the findings of fact and the conclusions of law.

The number of arbitrators shall be three, with each side to the dispute being entitled to appoint one arbitrator. The two arbitrators appointed by the parties shall appoint a third arbitrator who shall act as chairman of the proceedings. Vacancies in the post of chairman shall be filled by the president of the Bar Council of India. Other vacancies shall be filled by the respective nominating party. Proceedings shall continue from the stage they were at when the vacancy occurred.

If one of the parties refuses or otherwise fails to appoint an arbitrator within 30 days of the date the other party appoints its, the first appointed arbitrator shall be the sole arbitrator, provided that the arbitrator was validly and properly appointed.

All proceedings shall be conducted, including all documents presented in such proceedings, in the English language. The English language version of this Statement of Limited Warranty prevails over any other language version.

JAPAN

Governing Law: *The following sentence is added to this section:*

Any doubts concerning this Statement of Limited Warranty will be initially resolved between us in good faith and in accordance with the principle of mutual trust.

MALAYSIA

Limitation of Liability: *The word "SPECIAL" in item 3 of the fifth paragraph is deleted.*

NEW ZEALAND

What this Warranty Covers: *The following paragraph is added to this section:*

The warranties specified in this section are in addition to any rights you may have under the Consumer Guarantees Act 1993 or other legislation which cannot be excluded or limited. The Consumer Guarantees Act 1993 will not apply in respect of any goods which IBM provides, if you require the goods for the purposes of a business as defined in that Act.

Limitation of Liability: *The following is added to this section:*

Where Machines are not acquired for the purposes of a business as defined in the Consumer Guarantees Act 1993, the limitations in this section are subject to the limitations in that Act.

PEOPLE'S REPUBLIC OF CHINA (PRC)

Governing Law: *The following replaces "laws of the country in which you acquired the Machine" in the first sentence:*

laws of the State of New York, United States of America (except when local law requires otherwise).

PHILIPPINES

Limitation of Liability: *Item 3 in the fifth paragraph is replaced by the following:*

SPECIAL (INCLUDING NOMINAL AND EXEMPLARY DAMAGES), MORAL, INCIDENTAL, OR INDIRECT DAMAGES FOR ANY ECONOMIC CONSEQUENTIAL DAMAGES; OR

Arbitration: The following is added under this heading

Disputes arising out of or in connection with this Statement of Limited Warranty shall be finally settled by arbitration which shall be held in Metro Manila, Philippines in accordance with the laws of the Philippines then in effect. The

arbitration award shall be final and binding for the parties without appeal and shall be in writing and set forth the findings of fact and the conclusions of law.

The number of arbitrators shall be three, with each side to the dispute being entitled to appoint one arbitrator. The two arbitrators appointed by the parties shall appoint a third arbitrator who shall act as chairman of the proceedings. Vacancies in the post of chairman shall be filled by the president of the Philippine Dispute Resolution Center, Inc.. Other vacancies shall be filled by the respective nominating party. Proceedings shall continue from the stage they were at when the vacancy occurred.

If one of the parties refuses or otherwise fails to appoint an arbitrator within 30 days of the date the other party appoints its, the first appointed arbitrator shall be the sole arbitrator, provided that the arbitrator was validly and properly appointed.

All proceedings shall be conducted, including all documents presented in such proceedings, in the English language. The English language version of this Statement of Limited Warranty prevails over any other language version.

SINGAPORE

Limitation of Liability: The words "SPECIAL" and "ECONOMIC" in item 3 in the fifth paragraph are deleted.

EUROPE, MIDDLE EAST, AFRICA (EMEA)

THE FOLLOWING TERMS APPLY TO ALL EMEA COUNTRIES:

The terms of this Statement of Limited Warranty apply to Machines purchased from IBM or an IBM reseller.

Hot to Obtain Warranty Service: If you purchase a Machine in Austria, Belgium, Cyprus, Denmark, Estonia, Finland, France, Germany, Greece, Iceland, Ireland, Italy, Latvia, Liechtenstein, Lithuania, Luxembourg, Monaco, Netherlands, Norway, Portugal, Spain, San Marino, Sweden, Switzerland, United Kingdom or Vatican State, you may obtain warranty service for that Machine in any of those countries from either (1) an IBM reseller approved to perform warranty service or (2) from IBM, provided the Machine has been announced and made available by IBM in the country in which you wish to obtain service. If you purchased a Personal Computer Machine in Albania, Armenia, Belarus, Bosnia and Herzegovina, Bulgaria, Croatia, Czech Republic, Georgia, Hungary, Kazakhstan, Kyrgyzstan, Federal Republic of Yugoslavia, Former Yugoslav Republic of Macedonia (FYROM), Moldova, Poland, Romania, Russia, Slovak Republic, Slovenia, or Ukraine, you may obtain warranty service for that Machine in any of those countries from either (1) an IBM reseller approved to perform warranty service or (2) from IBM.

If you purchase a Machine in a Middle Eastern or African country, you may obtain warranty service for that Machine from the IBM entity within the country of purchase, if that IBM entity provides warranty service in that country, or from an IBM reseller, approved by IBM to perform warranty service on that Machine in that country. Warranty service in Africa is available within 50 kilometers of an IBM approved service provider. You are responsible for transportation costs for Machines located outside 50 kilometers of an IBM approved service provider.

*Add the following paragraph in **Western Europe** (Austria, Belgium, Cyprus, Denmark, Finland, France, Germany, Greece, Iceland, Ireland, Italy, Liechtenstein, Luxembourg, Monaco, Netherlands, Norway, Portugal, Spain, San Marino, Sweden, Switzerland, United Kingdom, Vatican State):*

The warranty for Machines acquired in Western Europe shall be valid and applicable in all Western Europe countries provided the Machines have been announced and made available in such countries.

Governing Law:

The phrase "the laws of the country in which you acquired the Machine" is replaced by:

1) "the laws of Austria" in **Albania, Armenia, Azerbaijan, Belarus, Bosnia-Herzegovina, Bulgaria, Croatia, Georgia, Hungary, Kazakhstan, Kyrgyzstan, FYR Macedonia, Moldova, Poland, Romania, Russia, Slovakia, Slovenia, Tajikistan, Turkmenistan, Ukraine, Uzbekistan, and FR Yugoslavia;** 2) "the laws of France" in **Algeria, Benin, Burkina Faso, Cameroon, Cape Verde, Central African Republic, Chad, Comoros, Congo Republic, Djibouti, Democratic Republic of Congo, Equatorial Guinea, French Guiana, French Polynesia, Gabon, Gambia, Guinea, Guinea-Bissau, Ivory Coast, Lebanon, Madagascar, Mali, Mauritania, Mauritius, Mayotte, Morocco, New Caledonia, Niger, Reunion, Senegal, Seychelles, Togo, Tunisia, Vanuatu, and Wallis & Futuna;** 3) "the laws of Finland" in **Estonia, Latvia, and Lithuania;** 4) "the laws of England" in **Angola, Bahrain, Botswana, Burundi, Egypt, Eritrea, Ethiopia, Ghana, Jordan, Kenya, Kuwait, Liberia, Malawi, Malta, Mozambique, Nigeria, Oman, Pakistan, Qatar, Rwanda, Sao Tome, Saudi Arabia, Sierra Leone, Somalia, Tanzania, Uganda, United Arab Emirates, the United Kingdom, West Bank/Gaza, Yemen, Zambia, and Zimbabwe;** and 5) "the laws of South Africa" in **South Africa, Namibia, Lesotho and Swaziland.**

Jurisdiction: *The following exceptions are added to this section:*

1) In **Austria** the choice of jurisdiction for all disputes arising out of this Statement of Limited Warranty and relating thereto, including its existence, will be the competent court of law in Vienna, Austria (Inner-City); 2) in **Angola, Bahrain, Botswana, Burundi, Egypt, Eritrea, Ethiopia, Ghana, Jordan, Kenya, Kuwait, Liberia, Malawi, Malta, Mozambique, Nigeria, Oman, Pakistan, Qatar, Rwanda, Sao Tome, Saudi Arabia, Sierra Leone, Somalia, Tanzania, Uganda, United Arab Emirates, West Bank/Gaza, Yemen, Zambia, and Zimbabwe** all disputes arising out of this Statement of Limited Warranty or related to its execution, including summary proceedings, will be submitted to the exclusive jurisdiction of the English courts; 3) in **Belgium and Luxembourg**, all disputes arising out of this Statement of Limited Warranty or related to its interpretation or its execution, the law, and the courts of the capital city, of the country of your registered office and/or commercial site location only are competent; 4) in **France, Algeria, Benin, Burkina Faso, Cameroon, Cape Verde, Central African Republic, Chad, Comoros, Congo Republic, Djibouti, Democratic Republic of Congo, Equatorial Guinea, French Guiana, French Polynesia, Gabon, Gambia, Guinea, Guinea-Bissau, Ivory Coast, Lebanon, Madagascar, Mali, Mauritania, Mauritius, Mayotte, Morocco, New Caledonia, Niger, Reunion, Senegal, Seychelles, Togo, Tunisia, Vanuatu, and Wallis & Futuna** all disputes arising out of this Statement of Limited Warranty or related to its violation or execution, including summary proceedings, will be settled exclusively by the Commercial Court of Paris; 5) in **Russia**, all disputes arising out of or in relation to the interpretation, the violation, the termination, the

nullity of the execution of this Statement of Limited Warranty shall be settled by Arbitration Court of Moscow; 6) **in South Africa, Namibia, Lesotho and Swaziland**, both of us agree to submit all disputes relating to this Statement of Limited Warranty to the jurisdiction of the High Court in Johannesburg; 7) **in Turkey** all disputes arising out of or in connection with this Statement of Limited Warranty shall be resolved by the Istanbul Central (Sultanahmet) Courts and Execution Directorates of Istanbul, the Republic of Turkey; 8) in each of the following specified countries, any legal claim arising out of this Statement of Limited Warranty will be brought before, and settled exclusively by, the competent court of a) Athens for **Greece**, b) Tel Aviv-Jaffa for **Israel**, c) Milan for **Italy**, d) Lisbon for **Portugal**, and e) Madrid for **Spain**; and 9) **in the United Kingdom**, both of us agree to submit all disputes relating to this Statement of Limited Warranty to the jurisdiction of the English courts.

Arbitration: *The following is added under this heading:*

In Albania, Armenia, Azerbaijan, Belarus, Bosnia-Herzegovina, Bulgaria, Croatia, Georgia, Hungary, Kazakhstan, Kyrgyzstan, FYR Macedonia, Moldova, Poland, Romania, Russia, Slovakia, Slovenia, Tajikistan, Turkmenistan, Ukraine, Uzbekistan, and FR Yugoslavia all disputes arising out of this Statement of Limited Warranty or related to its violation, termination or nullity will be finally settled under the Rules of Arbitration and Conciliation of the International Arbitral Center of the Federal Economic Chamber in Vienna (Vienna Rules) by three arbitrators appointed in accordance with these rules. The arbitration will be held in Vienna, Austria, and the official language of the proceedings will be English. The decision of the arbitrators will be final and binding upon both parties. Therefore, pursuant to paragraph 598 (2) of the Austrian Code of Civil Procedure, the parties expressly waive the application of paragraph 595 (1) figure 7 of the Code. IBM may, however, institute proceedings in a competent court in the country of installation.

In Estonia, Latvia and Lithuania all disputes arising in connection with this Statement of Limited Warranty will be finally settled in arbitration that will be held in Helsinki, Finland in accordance with the arbitration laws of Finland then in effect. Each party will appoint one arbitrator. The arbitrators will then jointly appoint the chairman. If arbitrators cannot agree on the chairman, then the Central Chamber of Commerce in Helsinki will appoint the chairman.

EUROPEAN UNION (EU)

THE FOLLOWING TERMS APPLY TO ALL EU COUNTRIES:

Consumers have legal rights under applicable national legislation governing the sale of consumer goods. Such rights are not affected by the warranties provided in this Statement of Limited Warranty.

How to Obtain Warranty Service: *The following is added to this section:*

To obtain warranty service from IBM in EU countries, see the telephone listing in Part 3 - Warranty Information.

You may contact IBM at the following address:

IBM Warranty & Service Quality Dept.

PO Box 30

Spango Valley

Greenock

Scotland PA 16 OAH

**AUSTRIA, DENMARK, FINLAND, GREECE, ITALY, NETHERLANDS,
PORTUGAL, SPAIN, SWEDEN AND SWITZERLAND**

Limitation of Liability: *The following replaces the terms of this section in its entirety:*

Except as otherwise provided by mandatory law:

1. IBM's liability for any damages and losses that may arise as a consequence of the fulfillment of its obligations under or in connection with this Statement of Limited Warranty or due to any other cause related to this Statement of Limited Warranty is limited to the compensation of only those damages and losses proved and actually arising as an immediate and direct consequence of the non-fulfillment of such obligations (if IBM is at fault) or of such cause, for a maximum amount equal to the charges you paid for the Machine. For purposes of this item, the term "Machine" includes Machine Code and Licensed Internal Code ("LIC").

The above limitation shall not apply to damages for bodily injuries (including death) and damages to real property and tangible personal property for which IBM is legally liable.

2. **UNDER NO CIRCUMSTANCES IS IBM, ITS SUPPLIERS OR RESELLERS LIABLE FOR ANY OF THE FOLLOWING, EVEN IF INFORMED OF THEIR POSSIBILITY: 1) LOSS OF, OR DAMAGE TO, DATA; 2) INCIDENTAL OR INDIRECT DAMAGES, OR FOR ANY ECONOMIC CONSEQUENTIAL DAMAGES; 3) LOST PROFITS, EVEN IF THEY ARISE AS AN IMMEDIATE CONSEQUENCE OF THE EVENT THAT GENERATED THE DAMAGES; OR 4) LOSS OF BUSINESS, REVENUE, GOODWILL, OR ANTICIPATED SAVINGS.**

FRANCE AND BELGIUM

Limitation of Liability: *The following replaces the terms of this section in its entirety:*

Except as otherwise provided by mandatory law:

1. IBM's liability for any damages and losses that may arise as a consequence of the fulfillment of its obligations under or in connection with this Statement of Limited Warranty is limited to the compensation of only those damages and losses proved and actually arising as an immediate and direct consequence of the non-fulfillment of such obligations (if IBM is at fault), for a maximum amount equal to the charges you paid for the Machine that has caused the damages. For purposes of this item, the term "Machine" includes Machine Code and Licensed Internal Code ("LIC").

The above limitation shall not apply to damages for bodily injuries (including death) and damages to real property and tangible personal property for which IBM is legally liable.

2. **UNDER NO CIRCUMSTANCES IS IBM, ITS SUPPLIERS OR RESELLERS LIABLE FOR ANY OF THE FOLLOWING, EVEN IF INFORMED OF THEIR POSSIBILITY: 1) LOSS OF, OR DAMAGE TO, DATA; 2) INCIDENTAL OR INDIRECT DAMAGES, OR FOR ANY ECONOMIC CONSEQUENTIAL DAMAGES; 3) LOST PROFITS, EVEN IF THEY ARISE AS AN IMMEDIATE**

CONSEQUENCE OF THE EVENT THAT GENERATED THE DAMAGES;
OR 4) LOSS OF BUSINESS, REVENUE, GOODWILL, OR ANTICIPATED
SAVINGS.

THE FOLLOWING TERMS APPLY TO THE COUNTRY SPECIFIED:

AUSTRIA

What this Warranty Covers: *The following replaces the first sentence of the first paragraph of this section:*

The warranty for an IBM Machine covers the functionality of the Machine for its normal use and the Machine's conformity to its Specifications.

The following paragraphs are added to this Section:

The minimum warranty period for Machines is 12 months from the date of delivery. . The limitation period for consumers in action for breach of warranty is the statutory period as a minimum. In case IBM or your reseller is unable to repair an IBM Machine, you can alternatively ask for a partial refund as far as justified by the reduced value of the unrepaired Machine or ask for a cancellation of the respective agreement for such Machine and get your money refunded.

The second paragraph does not apply.

What IBM Will Do to Correct Problems: *The following is added to this section:*

During the warranty period, transportation for delivery of the failing Machine to IBM will be at IBM's expense.

Limitation of Liability: *The following paragraph is added to this section:*

The limitations and exclusions specified in the Statement of Limited Warranty will not apply to damages caused by IBM with fraud or gross negligence and for express warranty.

The following sentence is added to the end of item 2:

IBM's liability under this item is limited to the violation of essential contractual terms in cases of ordinary negligence.

EGYPT

Limitation of Liability: *The following replaces item 2 in this section:*

as to any other actual direct damages, IBM's liability will be limited to the total amount you paid for the Machine that is the subject of the claim. For purposes of this item, the term "Machine" includes Machine Code and Licensed Internal Code (LIC).

Applicability of suppliers and resellers (unchanged).

FRANCE

Limitation of Liability: *The following replaces the second sentence of the first paragraph of this section:*

In such instances, regardless of the basis on which you are entitled to claim damages from IBM, IBM is liable for no more than: *(items 1 and 2 unchanged).*

GERMANY

What this Warranty Covers: *The following replaces the first sentence of the first paragraph of this section:*

The warranty for an IBM Machine covers the functionality of the Machine for its normal use and the Machine's conformity to its Specifications.

The following paragraphs are added to this section:

The minimum warranty period for Machines is twelve months. In case IBM or your reseller is unable to repair an IBM Machine, you can alternatively ask for a partial refund as far as justified by the reduced value of the unrepaired Machine or ask for a cancellation of the respective agreement for such Machine and get your money refunded.

The second paragraph does not apply.

What IBM Will Do to Correct Problems: *The following is added to this section:*

During the warranty period, transportation for delivery of the failing Machine to IBM will be at IBM's expense.

Limitation of Liability: *The following paragraph is added to this section:*

The limitations and exclusions specified in the Statement of Limited Warranty will not apply to damages caused by IBM with fraud or gross negligence and for express warranty.

The following sentence is added to the end of item 2:

IBM's liability under this item is limited to the violation of essential contractual terms in cases of ordinary negligence.

HUNGARY

Limitation of Liability: *The following is added at the end of this section:*

The limitation and exclusion specified herein shall not apply to liability for a breach of contract damaging life, physical well-being, or health that has been caused intentionally, by gross negligence, or by a criminal act.

The parties accept the limitations of liability as valid provisions and state that the Section 314.(2) of the Hungarian Civil Code applies as the acquisition price as well as other advantages arising out of the present Statement of Limited Warranty balance this limitation of liability.

IRELAND

What this Warranty Covers: *The following is added to this section:*

Except as expressly provided in these terms and conditions, all statutory conditions, including all warranties implied, but without prejudice to the generality of the foregoing all warranties implied by the Sale of Goods Act 1893 or the Sale of Goods and Supply of Services Act 1980 are hereby excluded.

Limitation of Liability: *The following replaces the terms of this section in its entirety:*

For the purposes of this section, a "Default" means any act, statement, omission, or negligence on the part of IBM in connection with, or in relation to, the subject matter of this Statement of Limited Warranty in respect of which IBM is legally liable to you, whether in contract or tort. A number of Defaults which together result in, or contribute to, substantially the same loss or damage will be treated as one Default occurring on the date of occurrence of the last such Default.

Circumstances may arise where, because of a Default, you are entitled to recover damages from IBM.

This section sets out the extent of IBM's liability and your sole remedy.

1. IBM will accept unlimited liability for death or personal injury caused by the negligence of IBM.
2. Subject always to the Items for Which IBM is Not Liable below, IBM will accept unlimited liability for physical damage to your tangible property resulting from the negligence of IBM.
3. Except as provided in items 1 and 2 above, IBM's entire liability for actual damages for any one Default will not in any event exceed the greater of 1) EUR 125,000, or 2) 125% of the amount you paid for the Machine directly relating to the Default.

Items for Which IBM is Not Liable

Save with respect to any liability referred to in item 1 above, under no circumstances is IBM, its suppliers or resellers liable for any of the following, even if IBM or they were informed of the possibility of such losses:

1. loss of, or damage to, data;
2. special, indirect, or consequential loss; or
3. loss of profits, business, revenue, goodwill, or anticipated savings.

SLOVAKIA

Limitation of Liability: *The following is added to the end of the last paragraph:*

The limitations apply to the extent they are not prohibited under §§ 373-386 of the Slovak Commercial Code.

SOUTH AFRICA, NAMIBIA, BOTSWANA, LESOTHO AND SWAZILAND

Limitation of Liability: *The following is added to this section:*

IBM's entire liability to you for actual damages arising in all situations involving nonperformance by IBM in respect of the subject matter of this Statement of Warranty will be limited to the charge paid by you for the individual Machine that is the subject of your claim from IBM.

UNITED KINGDOM

Limitation of Liability: *The following replaces the terms of this section in its entirety:*

For the purposes of this section, a "Default" means any act, statement, omission, or negligence on the part of IBM in connection with, or in relation to, the subject matter of this Statement of Limited Warranty in respect of which IBM is legally

liable to you, whether in contract or tort. A number of Defaults which together result in, or contribute to, substantially the same loss or damage will be treated as one Default.

Circumstances may arise where, because of a Default, you are entitled to recover damages from IBM.

This section sets out the extent of IBM's liability and your sole remedy.

1. IBM will accept unlimited liability for:
 - a. death or personal injury caused by the negligence of IBM; and
 - b. any breach of its obligations implied by Section 12 of the Sale of Goods Act 1979 or Section 2 of the Supply of Goods and Services Act 1982, or any statutory modification or re-enactment of either such Section.
2. IBM will accept unlimited liability, subject always to the Items for Which IBM is Not Liable below, for physical damage to your tangible property resulting from the negligence of IBM.
3. IBM's entire liability for actual damages for any one Default will not in any event, except as provided in items 1 and 2 above, exceed the greater of 1) Pounds Sterling 75,000, or 2) 125% of the total purchase price payable or the charges for the Machine directly relating to the Default.

These limits also apply to IBM's suppliers and resellers. They state the maximum for which IBM and such suppliers and resellers are collectively responsible.

Items for Which IBM is Not Liable

Save with respect to any liability referred to in item 1 above, under no circumstances is IBM or any of its suppliers or resellers liable for any of the following, even if IBM or they were informed of the possibility of such losses:

1. loss of, or damage to, data;
2. special, indirect, or consequential loss; or
3. loss of profits, business, revenue, goodwill, or anticipated savings.

Part 3 - Warranty Information

This Part 3 provides information regarding the warranty applicable to your Machine, including the warranty period and type of warranty service IBM provides.

Warranty Period

The warranty period may vary by country or region and is specified in the table below. NOTE: "Region" means either Hong Kong or Macau Special Administrative Region of China.

DDS/5 Tape Drive

Country or Region of Purchase	Warranty Period	Type of Warranty Service
Worldwide	1 year	1

A warranty period of 1 year on parts and 1 year on labor means that IBM provides warranty service without charge for parts and labor during the 1 year warranty period.

Types of Warranty Service

If required, IBM provides repair or exchange service depending on the type of warranty service specified for your Machine in the above table and as described below. Warranty service may be provided by your reseller if approved by IBM to perform warranty service. Scheduling of service will depend upon the time of your call and is subject to parts availability. Service levels are response time objectives and are not guaranteed. The specified level of warranty service may not be available in all worldwide locations, additional charges may apply outside IBM's normal service area, contact your local IBM representative or your reseller for country and location specific information.

1. Customer Replaceable Unit ("CRU") Service

IBM will ship CRU parts to you for your replacement. If IBM instructs you to return the replaced CRU, you are responsible for returning it to IBM in accordance with IBM's instructions. If you do not return the defective CRU, if IBM so instructs, within 30 days of your receipt of the replacement CRU, IBM may charge you for the replacement.

2. On-site Service

IBM or your reseller will either repair or exchange the failing Machine at your location and verify its operation. You must provide suitable working area to allow disassembly and reassembly of the IBM Machine. The area must be clean, well lit and suitable for the purpose. **For some Machines, certain repairs may require sending the Machine to an IBM service center.**

3. Courier or Depot Service⁴

You will disconnect the failing Machine for collection arranged by IBM. IBM will provide you with a shipping container for you to return your Machine to a designated service center. A courier will pick up your Machine and deliver it to the designated service center. Following its repair or exchange, IBM will arrange the return delivery of the Machine to your location. You are responsible for its installation and verification.

4. Customer Carry-In or Mail-In Service

You will deliver or mail as IBM specifies (prepaid unless IBM specifies otherwise) the failing Machine suitably packaged to a location IBM designates. After IBM has repaired or exchanged the Machine, IBM will make it available for your collection or, for Mail-in Service, IBM will return it to you at IBM's expense, unless IBM specifies otherwise. You are responsible for the subsequent installation and verification of the Machine.

The IBM Machine Warranty worldwide web site at http://www.ibm.com/servers/support/machine_warranties/ provides a worldwide overview of IBM's Limited Warranty for Machines, a Glossary of IBM

4. This type of service is called ThinkPad EasyServ or EasyServ in some countries.

definitions, Frequently Asked Questions (FAQs) and Support by Product (Machine) with links to Product Support pages. **The IBM Statement of Limited Warranty is also available on this site in 29 languages.**

To obtain warranty service contact IBM or your IBM reseller. In Canada or the United States, call 1-800-IBM-SERV (426-7378). For other countries, see the telephone numbers below.

Phone numbers are subject to change without notice. For the latest phone number list, go to www-3.ibm.com/pc/support/site.wss/ and click **Support Phone List**.

Country or Region	Telephone Number	Country or Region	Telephone Number
Argentina	0800-666-0011	Malaysia	03-7727-7800
Australia	1300-130-426	Mexico	001-866-434-2080
Austria	01-24592-5901	Netherlands	020-514-5770
Belgium	Dutch 02-210-9820 French 02-210-9800	New Zealand	0800-446-149
Bolivia	0800-0189	Norway	66 81 11 00
Brazil	55-11-3889-8986	Peru	0-800-50-866
Canada	1-800-565-3344 Toronto 416-383-3344	Philippines	632-995-2225
Chile	800-224-488	Portugal	21-791 51 47
China (PRC)	800-810-1818	Russia	095-940-2000
China (Hong Kong S.A.R.)	852-2825-7799	Singapore	1800-840-9911
Columbia	980-912-3021	Spain	91-662 49 16
Denmark	45 20 82 00	Sweden	08-477 4420
Ecuador	1-800-426911 (option #4)	Switzerland	058-333-09-00
Finland	09-459 69 60	Taiwan	886-2-2725-9799
France	02 38 55 74 50	Thailand	66-2-273-4000
Germany	07032-1549 201	Turkey	00-800-446-32-041
Indonesia	021-523-8535	United Kingdom	0-1475-555 055
Ireland	01-815-9202	United States	1-800-426-7378
Italy	02-7031-6101	Uruguay	000-411-005-6649
Japan	Consumer customers 0120-887-870 Business customers 0120-887-874	Venezuela	0-800-100-2011
Luxembourg	298-977 5063	Vietnam	848-8295-160

Appendix F. Notices

IBM may not offer the products, services, or features discussed in this document in all countries. Consult your local IBM representative for information on the products and services currently available in your area. Any reference to an IBM product, program, or service is not intended to state or imply that only that IBM product, program, or service may be used. Any functionally equivalent product, program, or service that does not infringe any IBM intellectual property right may be used instead. However, it is the user's responsibility to evaluate and verify the operation of any non-IBM product, program, or service.

IBM may have patents or pending patent applications covering subject matter described in this document. The furnishing of this document does not give you any license to these patents. You can send license inquiries, in writing, to:

*IBM Director of Licensing
IBM Corporation
North Castle Drive
Armonk, NY 10504-1785
U.S.A.*

INTERNATIONAL BUSINESS MACHINES CORPORATION PROVIDES THIS PUBLICATION "AS IS" WITHOUT WARRANTY OF ANY KIND, EITHER EXPRESS OR IMPLIED, INCLUDING, BUT NOT LIMITED TO, THE IMPLIED WARRANTIES OF NON-INFRINGEMENT, MERCHANTABILITY OR FITNESS FOR A PARTICULAR PURPOSE. Some jurisdictions do not allow disclaimer of express or implied warranties in certain transactions, therefore, this statement may not apply to you.

This information could include technical inaccuracies or typographical errors. Changes are periodically made to the information herein; these changes will be incorporated in new editions of the publication. IBM may make improvements and/or changes in the product(s) and/or the program(s) described in this publication at any time without notice.

The products described in this document are not intended for use in implantation or other life support applications where malfunction may result in injury or death to persons. The information contained in this document does not affect or change IBM product specifications or warranties. Nothing in this document shall operate as an express or implied license or indemnity under the intellectual property rights of IBM or third parties. All information contained in this document was obtained in specific environments and is presented as an illustration. The result obtained in other operating environments may vary.

IBM may use or distribute any of the information you supply in any way it believes appropriate without incurring any obligation to you.

Any references in this publication to non-IBM Web sites are provided for convenience only and do not in any manner serve as an endorsement of those Web sites. The materials at those Web sites are not part of the materials for this IBM product, and use of those Web sites is at your own risk.

Any performance data contained herein was determined in a controlled environment. Therefore, the result obtained in other operating environments may

vary significantly. Some measurements may have been made on development-level systems and there is no guarantee that these measurements will be the same on generally available systems. Furthermore, some measurements may have been estimated through extrapolation. Actual results may vary. Users of this document should verify the applicable data for their specific environment.

Federal Communications Commission (FCC) statement

48X/32X/48X Max CD-RW Drive

Note: This equipment has been tested and found to comply with the limits for a Class B digital device, pursuant to Part 15 of the FCC Rules. These limits are designed to provide reasonable protection against harmful interference in a residential installation. This equipment generates, uses, and can radiate radio frequency energy and, if not installed and used in accordance with the instructions, may cause harmful interference to radio communications. However, there is no guarantee that interference will not occur in a particular installation. If this equipment does cause harmful interference to radio or television reception, which can be determined by turning the equipment off and on, the user is encouraged to try to correct the interference by one or more of the following measures:

- Reorient or relocate the receiving antenna.
- Increase the separation between the equipment and receiver.
- Connect the equipment into an outlet on a circuit different from that to which the receiver is connected.
- Consult an IBM authorized dealer or service representative for help.

Properly shielded and grounded cables and connectors must be used in order to meet FCC emission limits. Proper cables and connectors are available from IBM authorized dealers. IBM is not responsible for any radio or television interference caused by using other than recommended cables and connectors or by unauthorized changes or modifications to this equipment. Unauthorized changes or modifications could void the user's authority to operate the equipment.

This device complies with Part 15 of the FCC Rules. Operation is subject to the following two conditions: (1) this device may not cause harmful interference, and (2) this device must accept any interference received, including interference that may cause undesired operation.

Responsible party:

International Business Machines Corporation
New Orchard Road
Armonk, NY 10504
Telephone: 1-919-543-2193



Tested To Comply
With FCC Standards

FOR HOME OR OFFICE USE

Industry Canada Class B emission compliance statement

This Class B digital apparatus complies with Canadian ICES-003.

Avis de conformité a la réglementation d'Industrie Canada

Cet appareil numérique de la classe B est conforme à la norme NMB-003 du Canada.

Deutsche EMV-Direktive (electromagnetische Verträglichkeit)

Zulassungsbeseinigunglaut dem Deutschen Gesetz über die elektromagnetische Verträglichkeit von Geräten (EMVG) vom 30. August 1995 (bzw. der EMC EG Richtlinie 89/336):

Dieses Gerät ist berechtigt in Übereinstimmungmit dem Deutschen EMVG das EG-Konformitätszeichen - CE - zu führen. Verantwortlich für die Konformitätserklärung nach Paragraph 5 des EMVG ist die:

IBM Deutschland Informationssysteme GmbH, 70548 Stuttgart.

Informationen in Hinsicht EMVG Paragraph 3 Abs. (2) 2:

Das Gerät erfüllt die Schutzanforderungen nach EN 55024:1998 und EN 55022:1998 Klasse B.

EN 55022 Hinweis:

“Wird dieses Gerät in einer industriellen Umgebung betrieben (wie in EN 55022:B festgelegt), dann kann es dabei eventuell gestört werden. In solch einem FA11 ist der Abstand bzw. die Abschirmungzu der industriellen Störquelle zu vergrößern.”

Anmerkung:

Um die Einhaltung des EMVG sicherzustellen sind die Geräte, wie in den IBM Handbüchern angegeben, zu installieren und zu betreiben.

European Union - emission directive

This product is in conformity with the protection requirements of EU Council Directive 89/336/ECC on the approximation of the laws of the Member States relating to electromagnetic compatibility.

IBM can not accept responsibility for any failure to satisfy the protection requirements resulting from a non-recommended modification of the product, including the fitting of non-IBM option cards.

This product has been tested and found to comply with the limits for Class B Information Technology Equipment according to European Standard EN 55022. The limits for Class B equipment were derived for typical residential environments to provide reasonable protection against interference with licensed communication devices.

Union Européenne - Directive Conformité électromagnétique

Ce produit est conforme aux exigences de protection de la Directive 89/336/EEC du Conseil de l'UE sur le rapprochement des lois des États membres en matière de compatibilité électromagnétique.

IBM ne peut accepter aucune responsabilité pour le manquement aux exigences de protection résultant d'une modification non recommandée du produit, y compris l'installation de cartes autres que les cartes IBM.

Ce produit a été testé et il satisfait les conditions de l'équipement informatique de Classe B en vertu de Standard européen EN 55022. Les conditions pour l'équipement de Classe B ont été définies en fonction d'un contexte résidentiel ordinaire afin de fournir une protection raisonnable contre l'interférence d'appareils de communication autorisés.

Unione Europea - Directiva EMC (Conformidad electromagnética)

Este producto satisface los requisitos de protección del Consejo de la UE, Directiva 89/336/CEE en lo que a la legislatura de los Estados Miembros sobre compatibilidad electromagnética se refiere.

IBM no puede aceptar responsabilidad alguna si este producto deja de satisfacer dichos requisitos de protección como resultado de una modificación no recomendada del producto, incluyendo el ajuste de tarjetas de opción que no sean IBM.

Este producto ha sido probado y satisface los límites para Equipos Informáticos Clase B de conformidad con el Estándar Europeo EN 55022. Los límites para los equipos de Clase B se han establecido para entornos residenciales típicos a fin de proporcionar una protección razonable contra las interferencias con dispositivos de comunicación licenciados.

Union Europea - Normativa EMC

Questo prodotto è conforme alle normative di protezione ai sensi della Direttiva del Consiglio dell'Unione Europea 89/336/CEE sull'armonizzazione legislativa degli stati membri in materia di compatibilità elettromagnetica.

IBM non accetta responsabilità alcuna per la mancata conformità alle normative di protezione dovuta a modifiche non consigliate al prodotto, compresa l'installazione di schede e componenti di marca diversa da IBM.

Le prove effettuate sul presente prodotto hanno accertato che esso rientra nei limiti stabiliti per le apparecchiature di informatica Classe B ai sensi della Norma Europea EN 55022. I limiti delle apparecchiature della Classe B sono stati stabiliti al fine di fornire ragionevole protezione da interferenze mediante dispositivi di comunicazione in concessione in ambienti residenziali tipici.

이 기기는 가정용으로 전자파 적합등록을 한 기기로서
주거지역에서는 물론 모든 지역에서 사용할 수 있습니다.

この装置は、情報処理装置等電波障害自主規制協議会（VCCI）の基準に基づきクラスB情報技術装置です。この装置は、家庭環境で使用することを目的としていますが、この装置がラジオやテレビジョン受信機に近接して使用されると、受信障害を引き起こすことがあります。
取扱説明書に従って正しい取り扱いをして下さい。

Japanese statement of compliance for products less than or equal to 20 A per phase

高調波ガイドライン適合品

Trademarks

The following terms are trademarks of International Business Machines Corporation in the United States, other countries, or both:

- IBM
- IBM Logo
- HelpCenter

Microsoft, Windows, and Windows NT are trademarks of Microsoft Corporation in the United States, other countries, or both.

Other company, product, or service names may be trademarks or service marks of others.



Part Number: 22P7046

Printed in U.S.A.

(1P) P/N: 22P7046

